

# PUR Miniaturpuffer · PUR Miniature Buffers

## Butée Miniature en PUR · Respingenti Miniatura in PUR

### Amortiguadores Miniatura en PUR

**GB**

<b>Material</b>	PUR, micro-cellular Base: steel, zinc plated
<b>Load</b>	2 - 225 Nm
Temperature	-30°C - max. +80°C
Impact speed	max. 5 m/s
Long life time	Resistant to oil, grease, ozone, UV radiation, weathering and splash water
<b>Applications</b>	End stop of machines, Crane systems

**I**

<b>Materiale</b>	Poliuretano, cellulare Base: acciaio zincato
<b>Carico</b>	2 - 225 Nm
Temperatura	-30°C - +80°C
Velocità d'impatto	max. 5 m/s
Lunga durata	Resistente a oli, grasso, ozono, raggi ultravioletti, invecchiamento e acqua spruzzante
<b>Applicazioni</b>	Arresti di fine corsa di macchinari, Gru

**D**

<b>Material</b>	PUR, mikrozellig Basis: Stahl, verzinkt
<b>Belastung</b>	2 - 225 Nm
Temperaturbereich	-30°C bis max. +80°C
Aufprallgeschwindigkeit	max. 5 m/s
Lange Lebensdauer	Beständigkeit gegen Öle, Fette, Ozon, UV-Strahlung, Alterung, Spritzwasser
<b>Einsatzgebiete</b>	Endanschläge von Maschinen Krananlagen

**F**

<b>Matière</b>	PUR, cellulaire Base: steel, acier zingué
<b>Charge</b>	2 - 225 Nm
Températures	-30°C - +80°C
Vitesse d'impact	max. 5 m/s
Longévité	Résistant à l'huile, aux graisses, à l'ozone, aux rayons UV, au vieillessement et éclaboussure
<b>Applications</b>	Butées de fin de course sur des machines, grues

**E**

<b>Material</b>	PUR, celular Basa: zincada
<b>Carga</b>	2 - 225 Nm
Temperaturas	-30°C - +80°C
Velocidad de impacto	max. 5 m/s
Larga vida útil	Resistente a aceites, grasas, ozono, radiación UV, envejecimiento y agua rociado
<b>Aplicaciones</b>	Topes finales de máquinas, Grúas

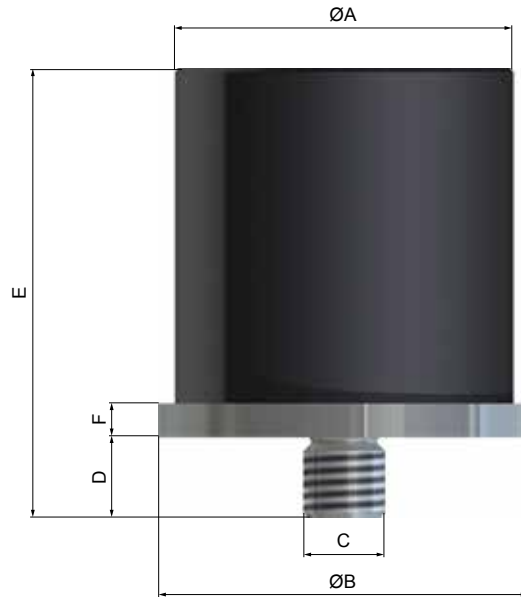

## ABMESSUNGEN - DIMENSIONS - DIMENSIONI - DIMENSIONES

	Federweg max. max. Deflection max. Écrasement max. Deformazione máx. Aplastante	Energieaufnahme • Energy absorption • Energie d'absorption Assorbimento d'energia • Absorción de energia		øA	øB	C	D	E	F
	mm	Dauerbelastung • Constant load Charge permanente • Carico permanente Carga continua	Notfall • Emergency Urgence • Emergenza Emergencia	mm	mm	mm	mm	mm	mm
		Nm	Nm						
WMB-10-10-6	8	2	3	10	11	M3	3	15,5	3
WMB-20-20-6	16	10	16	20	23	M6	6	28,5	3
WMB-20-20-6-M5	16	10	16	20	23	M5	5	27,5	3
WMB-30-30-6	24	45	85	30	33	M6	6	38,5	3
WMB-40-40-6	32	85	135	40	45	M8	8	50,5	3
WMB-50-50-6	40	170	225	50	55	M12	12	66,5	5

## EINBAU - INSTALLATION - MONTAGE - INSTALLAZIONE - MONTAJE

Basis muss mit dem kompletten Durchmesser plan auf dem Gegenstück aufliegen.

**Empfehlung:** Einschraubgewinde mit Schraubensicherungskleber sichern.

The entire diameter of the base must lie flat on the counterpart.

**Recommendation:** secure screw-in thread with a screw-locking adhesive.

La base doit reposer à plat de son diamètre entier sur la contre-pièce.

**Recommandation:** fixer le filetage avec un frein-filet.

L'intero diametro della base deve sempre poggiare in piano sul controprezzo.

**Raccomandazione:** assicurare l'estremità filettata con un frenafilletti adesivo.

La base deberá colocarse con el diámetro completo plano en la contrapieza.

**Recomendación:** asegurar el racor de sujeción con pegamento adhesivo de fijación.

