

Shock Absorbers

Mega-Line WE-M 1,5

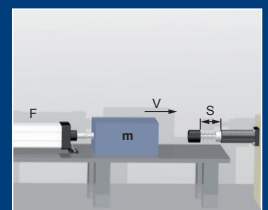

ONLINE
Calculation +
2D / 3D CAD Download



Benefits

Helix-Principle:

- Max. +300% Energy
- Max. -50% Costs / Nm

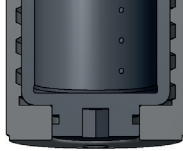

Pro Adjust:

- Protected adjustment



ProTec:

- Solid body without retaining ring

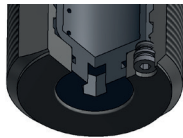

Piston:

- Hardened, Aluminium-Titanium-Nitride coated
- Special seals + oils



Extended life cycle:

- Nitrated guidance system

Integrated end stop:

- Max. security

Models:

- Black finish

Temperature:

Standard: -20°C-...+80°C

Low temperature: -50°C-...+60°C

High temperature: 0°C-...+120°C

Special edition :

- ProSurf
- V4A(/DIN1.440/AISL 316L)
- For pressure chambers up to 7 bar
- USDA-H 1 compliant for food industry
- Cleanroom

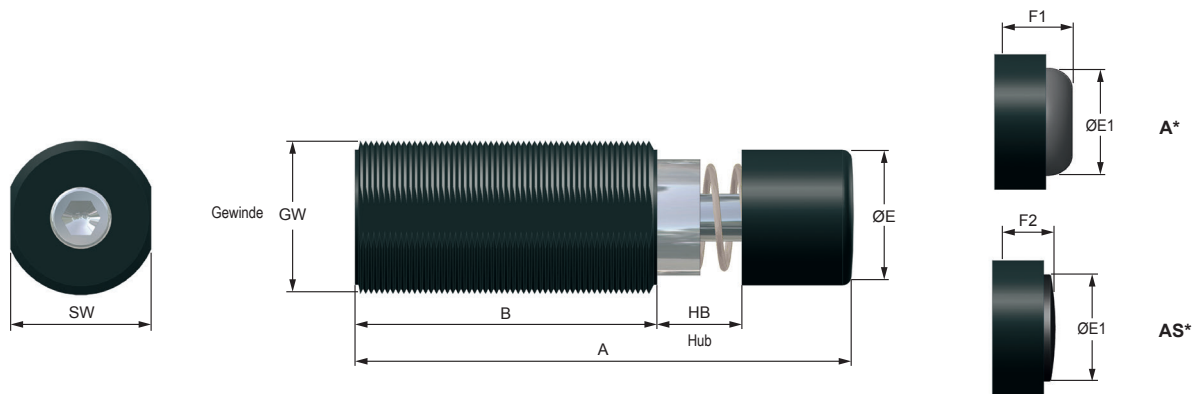

*A: PU / AS: Steel
Add "A / AS" after the part no.

DIMENSIONS

	GW*	A	B	ø E	ø E1	F1	F2	SW
		mm	mm	mm	mm	mm	mm	mm
WE-M 1,5 x 1	M 45 x 2	148	89	39,6	31	18	13	41
WE-M 1,5 x 2	M 45 x 2	198	114	39,6	31	18	13	41
WE-M 1,5 x 3	M 45 x 2	248	139	39,6	31	18	13	41

SPECIAL THREAD - from stock

Series	Code	Threads	Example
1,5	K	M 42x1,5	WE-M 1,5x1-1K
1,5	H	M 42x2	WE-M 1,5x1-1H
1,5	L	M 45x1,5	WE-M 1,5x1-1L
1,5	U	1 3/4-12 UNF	WE-M 1,5x1-1U

STAINLESS STEEL - from stock

Series	Code	Threads	Example
1,5X1		M 45x2	WE-M 1,5X1-1-VA
1,5X1	L	M 45x1,5	WE-M 1,5X1-1L-VA
1,5X1	U	1 3/4-12 UNF	WE-M 1,5X1-1U-VA
1,5X2		M 45x2	WE-M 1,5X2-1-VA
1,5X2	L	M 45x1,5	WE-M 1,5X2-1L-VA
1,5X2	U	1 3/4-12 UNF	WE-M 1,5X2-1U-VA
1,5X3		M 45x2	WE-M 1,5X3-1-VA
1,5X3	L	M 45x1,5	WE-M 1,5X3-1L-VA
1,5X3	U	1 3/4-12 UNF	WE-M 1,5X3-1U-VA

PERFORMANCE

	Stroke	Energy absorption			Effective mass				
		Constant load*		External tank**	-0 (very soft)	-1 (soft)	-2 (medium)	-3 (hard)	-4 (very hard)
		Nm/HB (max.)	Nm/h (max.)		Nm/h	min. - max.kg	min. - max.kg	min. - max.kg	min. - max.kg
WE-M 1,5 x 1	25	870	261.000	450.000	30 - 250	150 - 21.000	6.200 - 240.000	-	-
WE-M 1,5 x 2	50	1350	340.000	544.000	45 - 430	300 - 26.000	10.800 - 330.000	-	-
WE-M 1,5 x 3	75	2100	420.000	670.000	70 - 670	450 - 27.600	16.800 - 500.000	-	-

Technical data at + 20°C

Technical Data

Weight	1,5 x 1:	0,95 kg
	1,5 x 2:	1,10 kg
	1,5 x 3:	1,20 kg
Impact speed	WE-M:	0,02 - 6,0 m/s
Return spring force	1,5 x 1 :	50 N/min - 70 N/max
	1,5 x 2 :	35 N/min - 70 N/max
	1,5 x 3 :	35 N/min - 80 N/max
Torque:	1,5 :	40 Nm
Max. force by using the flats		
Housing		Black finish
Piston rod		Hardened stainless steel
RoHS - compliant		Directive 2002/95/EG

Accessories

Lock nut

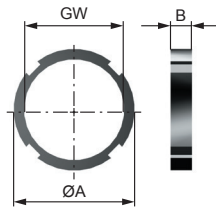

Code.: S24012

GW	ØA mm	B mm	Code
M42x1,5	54	8	S24012K
M45x1,5	54	8	S24012L
M45x2	54	8	S24012
1 3/4-12UNF	54	8	S24012U
Edelstahl			
M42x1,5	54	8	S24012K-VA
M45x1,5	54	8	S24012L-VA
M45x2	54	8	S24012VA

Stop limit nut

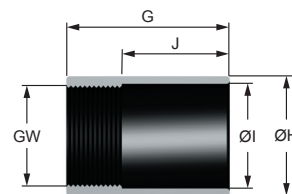

Code.: S24018

GW	ØI mm	ØH mm	G mm	J mm	Code
M42x1,5	49	57	65	35	S24018K
M45x1,5	49	57	65	35	S24018L
M45x2	47	54	65	35	S24018

Square flange

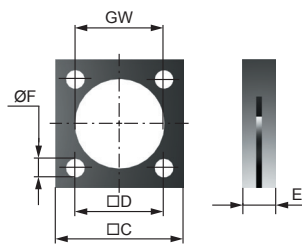

Code.: S24014

GW	ØF mm	E mm	D mm	C mm	Code
M42x1,5	9	12	43	55	S24014K
M45x1,5	9	12	42	55	S24014L
M45x2	9	12	42	55	S24014
1 3/4-12 UNF	9	12	42	55	S24014U

Foot mounting

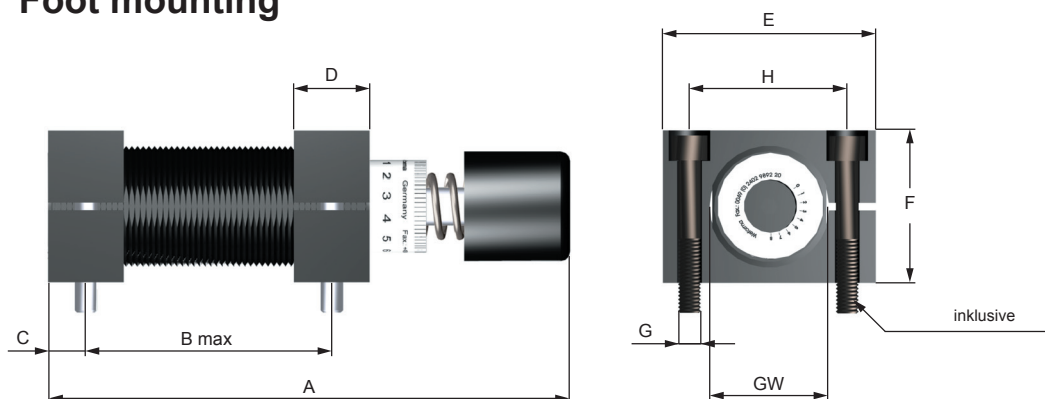

	GW*	A	B max	C	D	E	F	G	H	Code
		mm	mm	mm	mm	mm	mm	mm	mm	
1,5 x 1	M 45 x 2	148	64	12,5	25	80	56	M8	58	S24015
1,5 x 2	M 45 x 2	198	89	12,5	25	80	56	M8	58	S24015
1,5 x 3	M 45 x 2	248	114	12,5	25	80	56	M8	58	S24015

Accessories

Clevis mounting

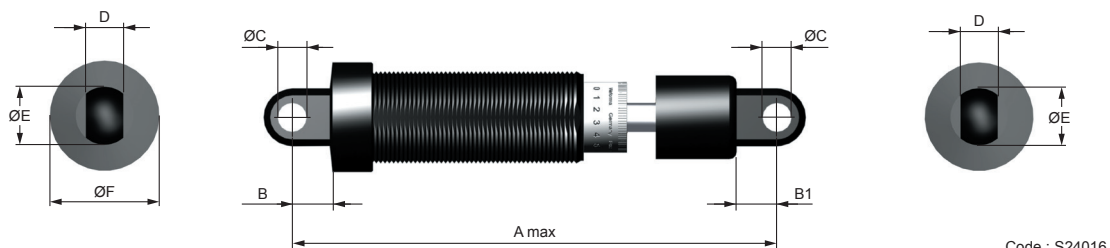

Code.: S24016

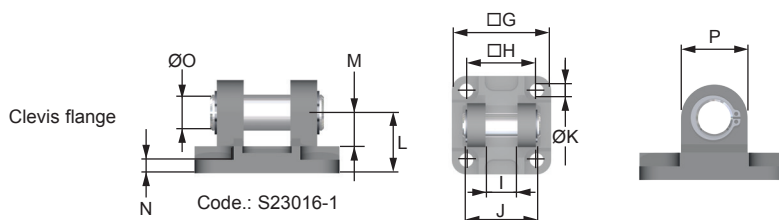

Code.: S23016-1

Pull: End stop required 1 mm before the stroke ends

Standard: Shock absorber with clevis mounting is delivered without return spring.
Return spring is available on request.

	GW*	A max	B	B1	ø C	D	ø E	ø F	G	H	I	J	ø K	L	M	N	ø O	P
		mm	mm	mm	mm	mm	mm	mm	mm	mm	mm	mm	mm	mm	mm	mm	mm	mm
1,5 x 1K	M42x1,5	203	28	18	16	20	28	53	65	46	21	45	9	27	15	6	16	29
1,5 x 2K	M42x1,5	253	28	18	16	20	28	53	65	46	21	45	9	27	15	6	16	29
1,5 x 3K	M42x1,5	303	28	18	16	20	28	53	65	46	21	45	9	27	15	6	16	29
1,5 x 1L	M45x1,5	203	28	18	16	20	28	53	65	46	21	45	9	27	15	6	16	29
1,5 x 2L	M45x1,5	253	28	18	16	20	28	53	65	46	21	45	9	27	15	6	16	29
1,5 x 3L	M45x1,5	303	28	18	16	20	28	53	65	46	21	45	9	27	15	6	16	29
1,5 x 1	M45x2	203	28	18	16	20	28	53	65	46	21	45	9	27	15	6	16	29
1,5 x 2	M45x2	253	28	18	16	20	28	53	65	46	21	45	9	27	15	6	16	29
1,5 x 3	M45x2	303	28	18	16	20	28	53	65	46	21	45	9	27	15	6	16	29
1,5 x 1U	1 3/4-12UNF	203	28	18	16	20	28	53	65	46	21	45	9	27	15	6	16	29
1,5 x 2U	1 3/4-12UNF	253	28	18	16	20	28	53	65	46	21	45	9	27	15	6	16	29
1,5 x 3U	1 3/4-12UNF	303	28	18	16	20	28	53	65	46	21	45	9	27	15	6	16	29

AK 1

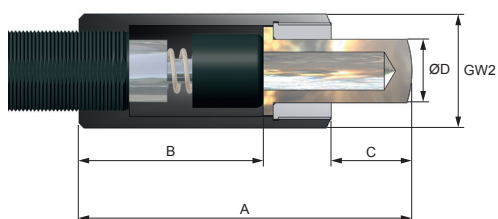

	GW1	GW2	A	B	C	ø D	Code
			mm	mm	mm	mm	
1,5 x 1	M45x2	M62x2	135,5	77	31,5	35	S24019
1,5 x 2	M45x2	M62x2	182,0	102	53,0	35	S24119
1,5 x 1L	M45x1,5	M62x2	135,5	77	31,5	35	S24119L
1,5 x 2L	M45x1,5	M62x2	182,0	102	53,0	35	S24119L

Accessories

Protection bellow

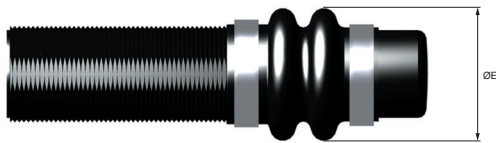

	Ø E mm	Code
1,5 x 1	60	S24017
1,5 x 2	80	S24117
1,5 x 3	80	S24217

External Tanks

AT 1

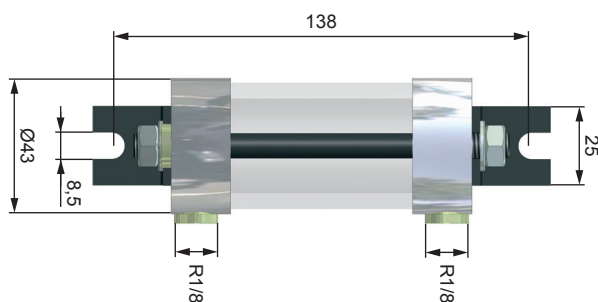

Code.: 23810

WE-M 1,5

WE-M 1,5 x 2 - 1AT
For shock absorbers without return spring

WE-M 1,5 x 2 - 1 ATF
For shock absorbers with return spring

WM-AT 1
For external Tanks

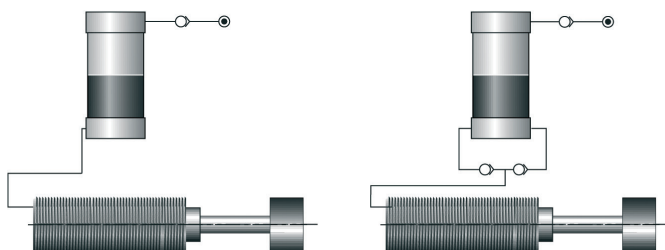

Benefits:

Optimum cooling and therefore higher energy absorption per hour“

Adjustment:

The adjustment can be done with the hexagonal recess in the bottom of the housing or with the adjustment ring at the piston rod side.

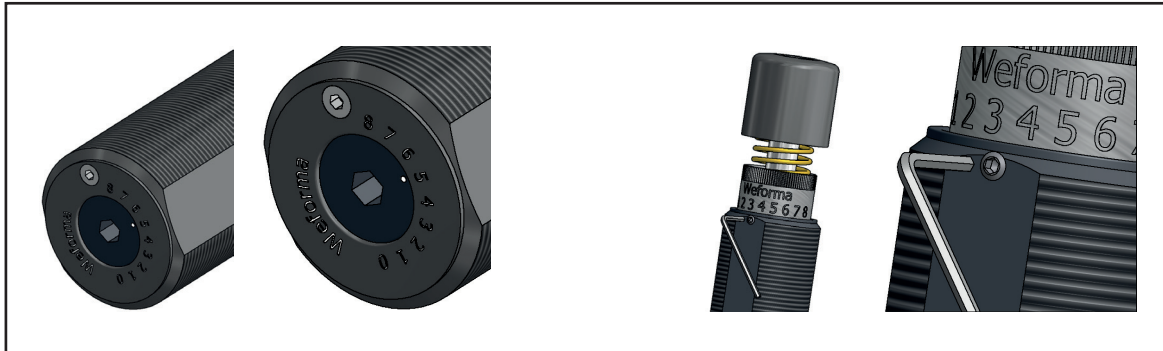

Adjustment: It is not allowed to adjust the shock absorber in operation conditions or during the operation.

0 = low damping
8 = high damping



In order to adjust the shock absorber set the adjustment screw to „6“ if the velocity is $<1,3$ m/s or to „4“ if the velocity is $>1,3$ m/s. Internal damage to the shock absorber can occur, if not adjusted in gradual increments. Do not drive in the final position under full load. If the damping is not sufficient, increase continuously by rotating the adjustment to the next higher number. Maximum damping is achieved, when the highest number on the scale is reached. If the mass impacts excessively hard on the shock absorber (stop cap) the damping should be reduced by rotation of the adjustment to the next smaller number. Minimum damping is at „0“ setting. Secure the adjustment with the threaded pin. A hexagonal key is supplied for this purpose. For sizes 1,25 and bigger the threaded pin is on the flats in the region of the front adjustment.

Installation

Foot mounting

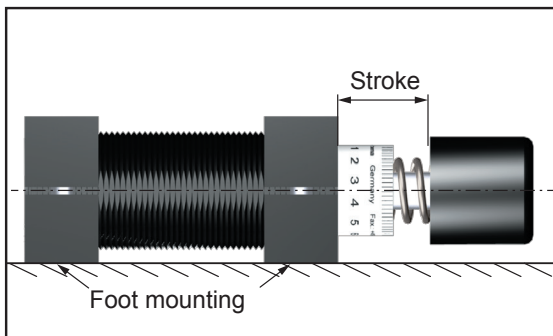

Clevis mounting

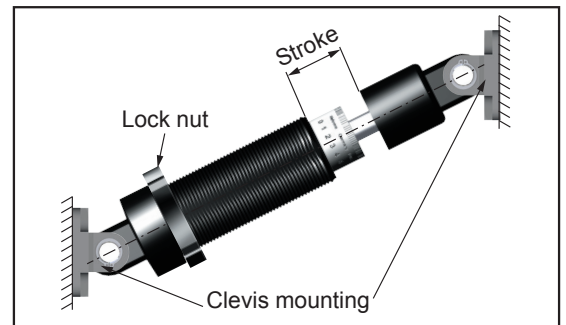

Installation with stop limit nut

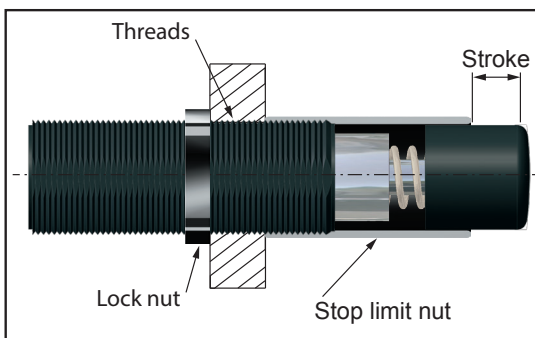

Installation with flange

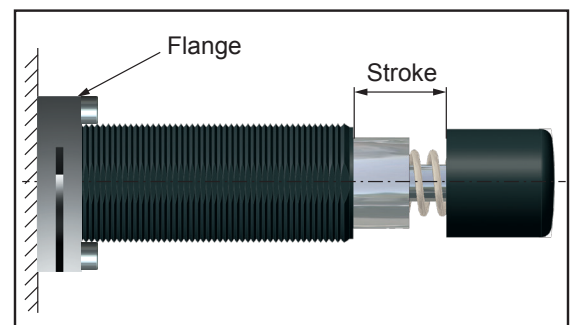

Safety Instructions

Before installation, commissioning, servicing and repair the data sheet is to be noticed. This work may only be performed by trained, introduced staff.

Electric connections according to the suitable national regulation. For Germany: VDE regulation VD E0100

Before all repair and servicing works the energy supplies (main switch, etc.) have to be switched off! Moreover, measures are necessary to prevent an unintentional reconnect. For example, a warning sign "service works" or "maintenance work", applied to the switch.

Designated use

Check before installation and make sure the type name on the shock absorber or on the packaging is corresponding with delivery note. Industrial shock absorbers are maintenance-free and ready for installation.

- Temperature influence: at higher temperatures the shock absorber characteristic will change.
- Movable loads have to be protected during the installation and maintenance against unintentional processes.
- In operation outside the allowed temperature range, the shock absorber can lose his function. Due to heat radiation don't paint the shock absorber.
- Fluids, gases and a dirty environment can affect or destroy the sealing system of the shock absorber. The result could be a failure malfunction. Piston rod and sealing system has to be protected against fluids, gases and a dirty environment.
- Damages at the piston rod can destroy the sealing system. Don't grease or oil the piston rod.
- Avoid traction forces on the piston rod to present internal damages.
- The shock absorber can be pulled out of the construction during the impact. The construction needs to be able to resist the max counterforce. Sufficient security must be calculated.
The maximum counterforces performed in the calculation program can vary from the really appearing counter forces, because these are based on theoretical values.

Fundamentals

Shock absorbers may under no circumstances be:

-painted



-welded



-held with clamps



-used on pull*



(exception: clevis mounting)

In hazardous environments (dirt, humidity, oil) shock absorbers must be protected against damage and failure with the necessary accessory. If several shock absorbers are used on the same application, the deceleration has to be distributed equally. The "Torque" (PERFORMANCE) indicates the maximum force by using the flats. The Weforma catalogue shows technical data with both minimum and maximum values. If a product is to be used in continuous operation and within a range of 20% from the minimum and maximum values shown, then written confirmation of suitability of use from Weforma is necessary.

Important information

Integrated end-stop

Up to the Mega-Line series 1,5 the shock absorbers are provided with an integrated end-stop. If the integrated end-stop is used the remaining energy before end of stroke must not be higher than 10% of the total energy. For all models which are used as an emergency stop an external fixed stop is necessary.

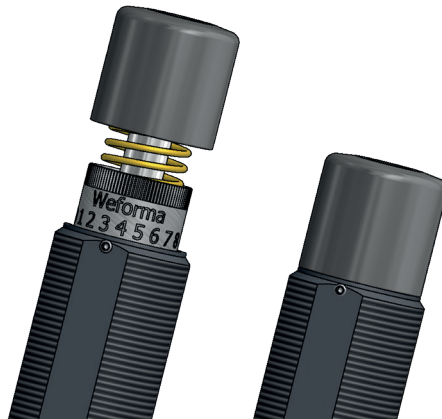

Installation situation

The installation situation is any, however always in such a way that the complete shock absorber stroke can be used. The shock absorbers must be mounted like that the forces in centerline about the piston rod are initiated. The maximum angle out of centre amounts to 2 °.

Liability

Due to the number of possible uses of our products and the conditions of use that lie outside of our scope of influence, we accept no liability as to whether the purchase object is suitable for the Client's intended purpose. The verification to this effect, in particular the verification as to whether the purchase object is suitable for the planned use, is the responsibility of the Client alone, unless expressly agreed otherwise in writing.

For the reasons we accept no liability for the suitability of the purchase object for the purpose intended by the Client, except in cases of intent or gross negligence.

With damages, the not designated use and from high-handed, in these instructions do not originate to intended interventions, any guarantee and liability claim goes out towards the manufacturer.

Guarantee

By non-use of the original spare parts the guarantee claim goes out.

Environment protection

By the exchange from damaged parts is to be respected to a proper disposal.