

Shock Absorbers

Mega-Line WE-M 0,5

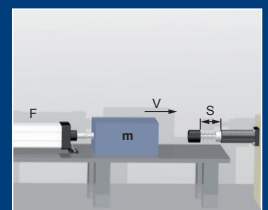

ONLINE
Calculation +
2D / 3D CAD Download



Benefits

Enlarged piston:

- Max. +400% energy
- Max. -50% costs / Nm



Piston:

- Hardened, aluminium-titanium-nitride coated

ProSurf:

- Surface protection against corrosion



Integrated stop:

- Max. security

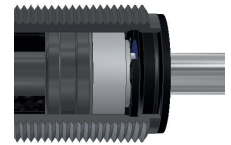

Flats :

- Fast mounting

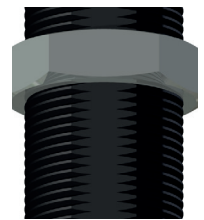

Special models:

- Stainless steel:
V4A/DIN1.4404/AISL 316L
- For pressure chambers up to 7 bar
- USDA-H 1 compliant for food industry
- Cleanroom

Temperature:

- Standard: -20°C - ...+80°
- Low-temperature: -50°C-...+60°C
- High-temperature: 0°C-...+120°C

Stop caps:

A:

- Standard from POM
- Increased protection of the impact surface

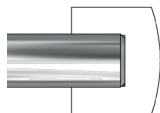

AP:

- 40% noise reduction due to PU
- Increased protection of the impact surface

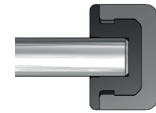

AP2:

- Longer life time compared to stop cap AP and plastic cap A

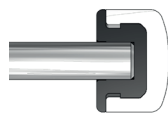

AS:

- From hardened steel
- For side forces and difficult operating conditions



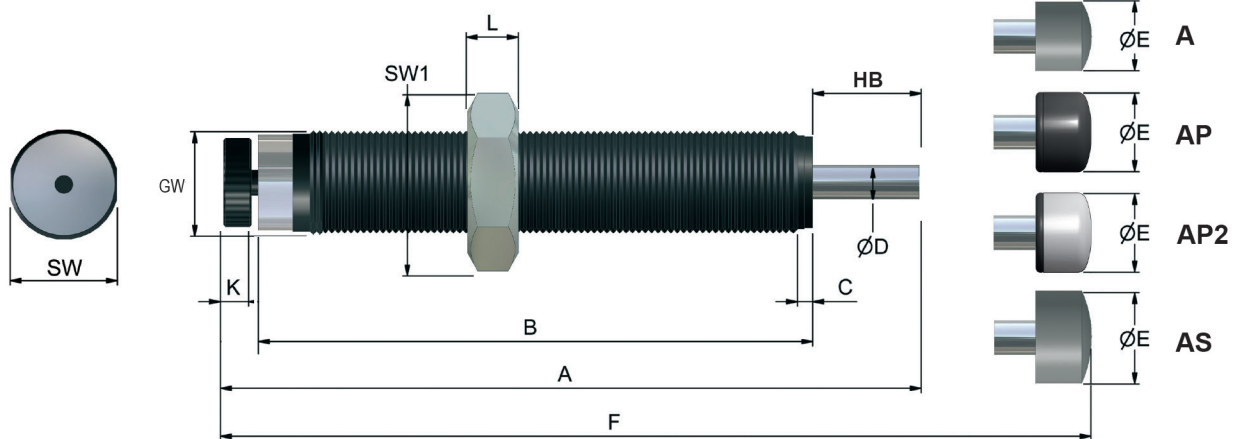

DIMENSIONS

GW*	A	B	C	øD	øE (A)	øE (AP / AP2)	øE (AS)	F (A)	F (AP / AP2)	F (AS)	K	L	SW	SW1	SW2	F (B)	øM	H
	mm	mm	mm	mm	mm	mm	mm	mm	mm	mm	mm	mm	mm	mm	mm	mm	mm	mm
WE-M 0,5 x 13	M 20 x 1	94	75	2,5	6	12	17	104	105	104	6	6	18	24	-	104	25	30
WE-M 0,5 x 19	M 20 x 1	113	88	2,5	6	12	17	123	125	123	6	6	18	24	-	123	25	36
WE-M 0,5 x 40	M 20 x 1	171	125	2,5	6	12	17	181	183	181	6	6	18	24	-	-	-	-

SPECIAL THREAD - from stock

Series	Code	Threads	Example
0,5 x 13	L	M 20x1,5	WE-M 0,5x13L
0,5 x 19	L	M 20x1,5	WE-M 0,5x19L
0,5 x 19	M	M 20x1,25	WE-M 0,5x19M
0,5 x 19	H	M 22x1,5	WE-M 0,5x19H
0,5 x 19	U	3/4-16 UNF	WE-M 0,5x19U
0,5 x 40	L	M 20x1,5	WE-M 0,5x40L

STAINLESS STEEL - from stock

Serie	Code	Threads	Example
0,5 x 13		M 20x1	WE-M 0,5x13-VA
0,5 x 13	L	M 20x1,5	WE-M 0,5x13L-VA
0,5 x 19		M 20x1	WE-M 0,5x19-VA
0,5 x 19	L	M 20x1,5	WE-M 0,5x19L-VA
0,5 x 19	U	3/4-16 UNF	WE-M 0,5x19U-VA
0,5 x 40		M 20x1	WE-M 0,5x40-VA
0,5 x 40	L	M 20x1,5	WE-M 0,5x40L-VA

PERFORMANCE

	Stroke	Energy absorption		Effective mass
		Constant load*		
	mm	Nm/HB (max.)	Nm/h (max.)	min. - max.kg
WE-M 0,5 x 13	13	65	52.000	6 - 3250
WE-M 0,5 x 19	19	100	76.500	9 - 4.500
WE-M 0,5 x 40	40	125	95.625	12 - 6.300

Technical data at + 20°C

Technical Data

Weight	0,5:	0,14 kg
	0,5 x 40:	0,20 kg
Impact speed	WE-M:	0,08 - 6,0 m/s
Return spring force	0,5 / 0,5 x 40:	12 N/min - 23 N/max
	Ausführung „BO“:	50 N/min - 70 N/max
Torque: max. force by using the flats	0,5 / 0,5 x 40:	25 Nm
Housing		ProSurf
Piston rod		Hardened stainless steel
RoHS - compliant		Directive 2002/95/EG
Included		1 lock nut

Accessories

Stop limit nut

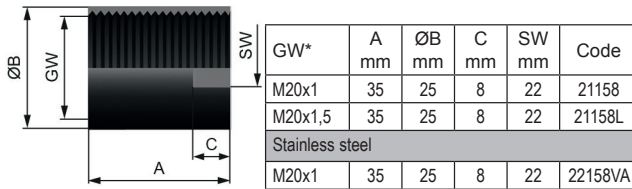

GW*	A mm	ØB mm	C mm	SW mm	Code
M20x1	35	25	8	22	21158
M20x1,5	35	25	8	22	21158L
Stainless steel					
M20x1	35	25	8	22	22158VA

Clamping flange

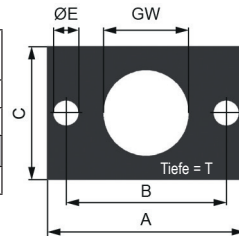

GW*	A	B	C	E	T	Code
M20x1	46	36	30	6,6	8	SK21153
M20x1,5	46	36	30	6,6	8	SK21153L
Stainless steel						
M20x1	46	36	30	6,6	8	SK21153VA
M20x1,5	46	36	30	6,6	8	SK21153L-VA
M22x1,5	46	36	30	6,6	8	SK21153H-VA

Rectangular flange

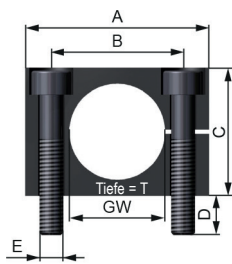

GW*	A mm	B mm	C mm	D mm	E mm	T mm	Code
M20x1	40	28	25	6	M6	20	S21153
M20x1,5	40	28	25	6	M6	20	S21153L

Lock nut

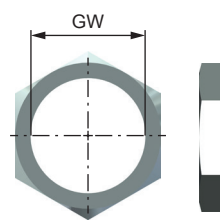

GW*	Code
M20x1	21152
M20x1,25	21152M
M20x1,5	21152L
M22x1,5	21152H
3/4-16UNF	21112U
Stainless steel	
M20x1	21152VA
M20x1,5	21152L-VA

Proximity Switch

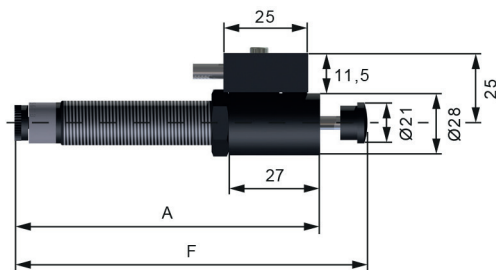

Included
Proximity Switch, Switch cap, stop limit nut

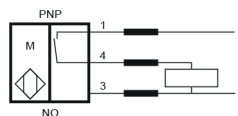

	A (mm)	F (mm)	Code
WE-M 0,5x40	138,5	181	S32164

	A (mm)	F (mm)	Code
WE-M 0,5x13	88,5	104	S32164
WE-M 0,5x19	101,5	123	S32164

Double wiper

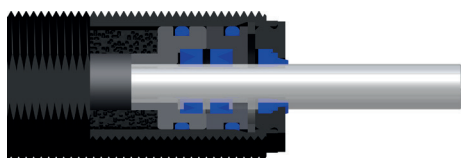

Used in applications with:

- Liquid
- Compressed air
- Dust

Accessories

Clevis mounting

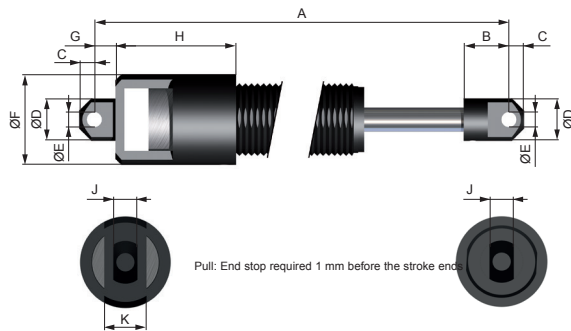

	GW*	A mm	B mm	C mm	øD mm	øE mm	øF mm	G mm	H mm	J mm	K mm
WE-M 0,5x13SB	M20x1	119	13	5	12	5	26	5	35	6	12
WE-M 0,5x19SB	M20x1	138	13	5	12	5	26	5	35	6	12

Art.-Nr.: S21116

Shock Absorbers with protection bellow

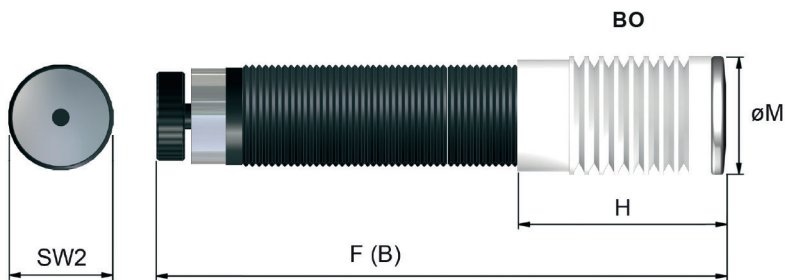

Material: PTFE / stop cap: stainless steel
 Ordering information: -M 0,5x19 - BO

Solutions for Side Forces

1) AK 1

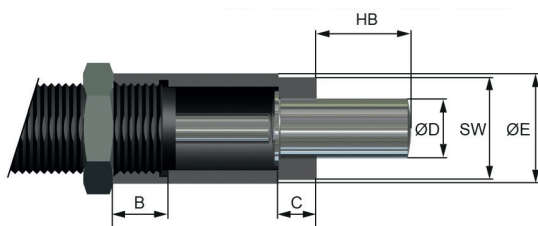

	GW*	A mm	B mm	C mm	Ø D mm	Ø E mm	SW mm	Code
0,5x19	M 20 x 1	42	16	8	12	24	22	S21119
0,5x19L	M 20 x 1,5	42	16	8	12	24	22	S21119L

AK 2

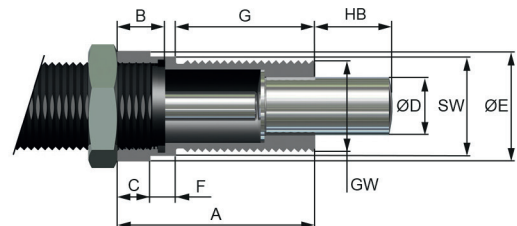

	GW*	A mm	B mm	C mm	Ø D mm	Ø E mm	F mm	G mm	SW mm	Code
0,5x13	M20x1	34	9	7	12	24	7	20	22	S21919-AK2
0,5x19	M20x1	38	9	6	12	24	7	25	22	S21119-AK2
0,5x19L	M20x1,5	38	9	6	12	24	7	25	22	S21119L-AK2

2) WEB-M 0,5

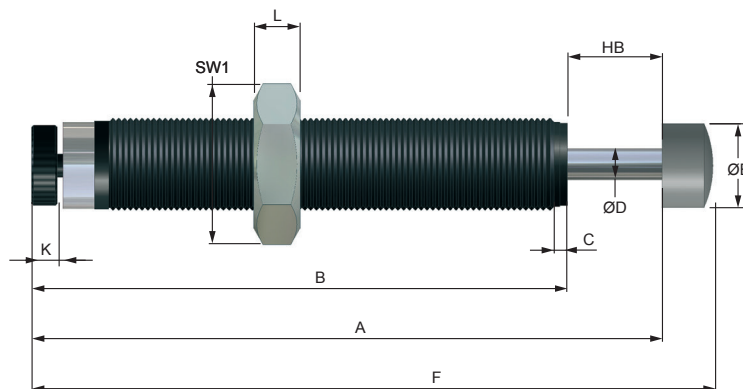

BENEFITS

Designed for side forces up to 15° without additional mounting parts;
included steel stop cap

DIMENSIONS

	GW*	A	A 1	B	C	Ø D	Ø E	L	SW	SW 1
		mm	mm	mm	mm	mm	mm	mm	mm	mm
WEB-M 0,5 x 19	M 20 x 1,0	117,0	123,0	88,0	2,5	6	16	6	18	24
WEB-M 0,5 x 19L	M 20 x 1,5	117,0	123,0	88,0	2,5	6	16	6	18	24

PERFORMANCE

	Stroke	Energy absorption		Effective mass					Return spring force		Torque	Weight
				-0 (very soft)	-1 (soft)	-2 (medium)	-3 (hard)	-4 (very hard)	min. N	max. N		
	mm	Nm/HB (max.)	Nm/h (max.)	min.-max.kg	min.-max.kg	min.-max.kg	min.-max.kg	min.-max.kg	min. N	max. N	Nm max.	kg
WEB-M 0,5x19	19	80	76800	-	9 - 4500	-	-	-	12	23	25	0,14

Installation

Installation with Lock nut

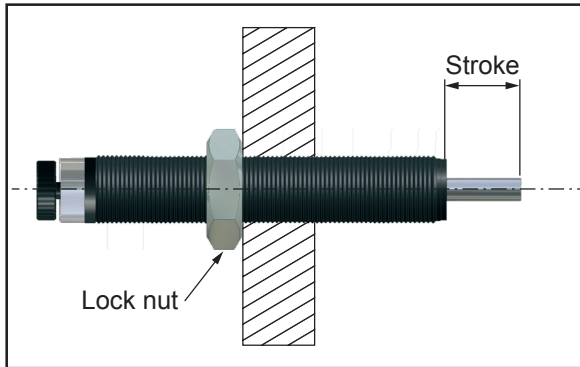

Installation with flange

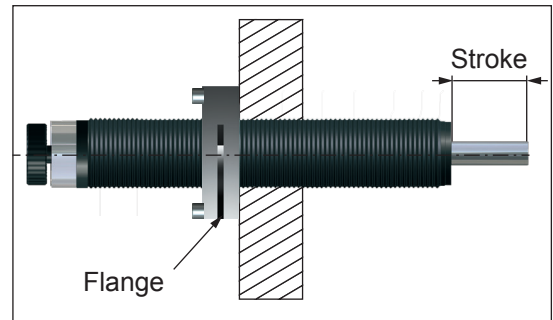

Installation with stop limit nut

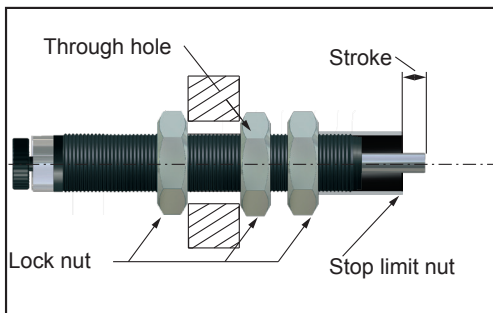

Clevis mounting

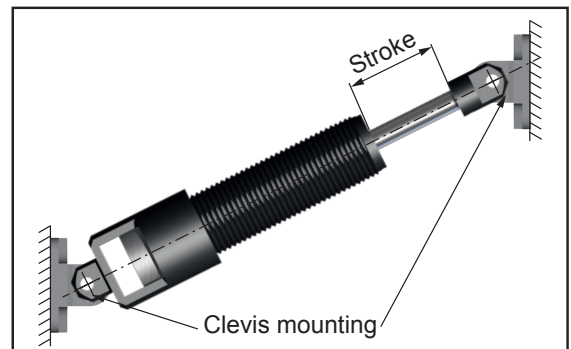

Adjustment:

The damping factor is adjusted with the adjusting screw at the back-sided end of the shock absorber. The damping depends from the impact speed and the effective mass. Set possibilities on the scale 0-8

0 = low damping

8 = high damping



Adjustment: It is not allowed to adjust the shock absorber in operation conditions or during the operation.

In order to adjust the shock absorber set the adjustment screw to „6“ if the velocity is $<1,3$ m/s or to „4“ if the velocity is $>1,3$ m/s. Internal damage to the shock absorber can occur, if not adjusted in gradual increments. Do not drive in the final position under full load. If the damping is not sufficient, increase continuously by rotating the adjustment to the next higher number. Maximum damping is achieved, when the highest number on the scale is reached. If the mass impacts excessively hard on the shock absorber (stop cap) the damping should be reduced by rotation of the adjustment to the next smaller number. Minimum damping is at „0“ setting. Secure the adjustment with the threaded pin. A hexagonal key is supplied for this purpose



Safety Instructions

Before installation, commissioning, servicing and repair the data sheet is to be noticed. This work may only be performed by trained, introduced staff.

Electric connections according to the suitable national regulation. For Germany: VDE regulation VD E0100

Before all repair and servicing works the energy supplies (main switch, etc.) have to be switched off! Moreover, measures are necessary to prevent an unintentional reconnect. For example, a warning sign "service works" or "maintenance work", applied to the switch.

Designated use

Check before installation and make sure the type name on the shock absorber or on the packaging is corresponding with delivery note. Industrial shock absorbers are maintenance-free and ready for installation.

- Temperature influence: at higher temperatures the shock absorber characteristic will change.
- Movable loads have to be protected during the installation and maintenance against unintentional processes.
- In operation outside the allowed temperature range, the shock absorber can lose his function. Due to heat radiation don't paint the shock absorber.
- Fluids, gases and a dirty environment can affect or destroy the sealing system of the shock absorber. The result could be a failure malfunction. Piston rod and sealing system has to be protected against fluids, gases and a dirty environment.
- Damages at the piston rod can destroy the sealing system. Don't grease or oil the piston rod.
- Avoid traction forces on the piston rod to present internal damages.
- The shock absorber can be pulled out of the construction during the impact. The construction needs to be able to resist the max counterforce. Sufficient security must be calculated.
The maximum counterforces performed in the calculation program can vary from the really appearing counter forces, because these are based on theoretical values.

Fundamentals

Shock absorbers may under no circumstances be:

-painted



-welded



-held with clamps



-used on pull*



(exception: clevis mounting)

In hazardous environments (dirt, humidity, oil) shock absorbers must be protected against damage and failure with the necessary accessory. If several shock absorbers are used on the same application, the deceleration has to be distributed equally. The "Torque" (PERFORMANCE) indicates the maximum force by using the flats. The Weforma catalogue shows technical data with both minimum and maximum values. If a product is to be used in continuous operation and within a range of 20% from the minimum and maximum values shown, then written confirmation of suitability of use from Weforma is necessary.

Important information

Integrated end-stop

Up to the WE-M 0,5 Mega-Line series the shock absorbers are provided with an integrated end-stop. If the integrated end-stop is used the remaining energy before end of stroke must not be higher than 10% of the total energy. For all models which are used as an emergency stop an external fixed stop is necessary.

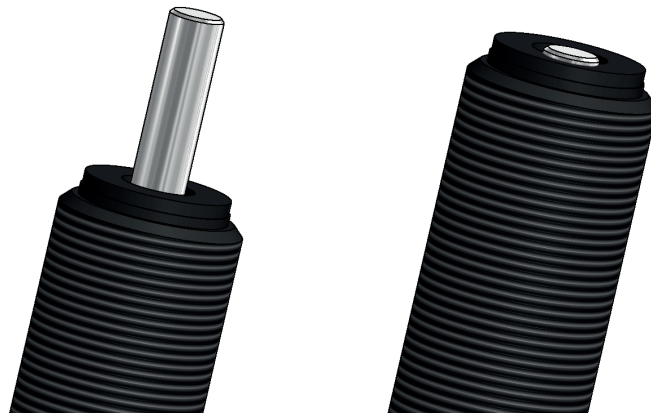

Installation situation

The installation situation is any, however always in such a way that the complete shock absorber stroke can be used. The shock absorbers must be mounted like that the forces in centerline about the piston rod are initiated. The maximum angle out of centre amounts to 3 °. With a bigger angle out of centre an AK1 / AK2 (see ``solutions for side forces'`) must be used or the shock absorber serie: WEB

Liability

Due to the number of possible uses of our products and the conditions of use that lie outside of our scope of influence, we accept no liability as to whether the purchase object is suitable for the Client's intended purpose. The verification to this effect, in particular the verification as to whether the purchase object is suitable for the planned use, is the responsibility of the Client alone, unless expressly agreed otherwise in writing.

For the reasons we accept no liability for the suitability of the purchase object for the purpose intended by the Client, except in cases of intent or gross negligence.

With damages, the not designated use and from high-handed, in these instructions do not originate to intended interventions, any guarantee and liability claim goes out towards the manufacturer.

Guarantee

By non-use of the original spare parts the guarantee claim goes out.

Environment protection

By the exchange from damaged parts is to be respected to a proper disposal.