

Shock Absorbers

Mega-Line WE-M 0,1

Mega-Line WE-M 0,15

Mega-Line WE-M 0,2



ONLINE
Calculation +
2D / 3D CAD Download

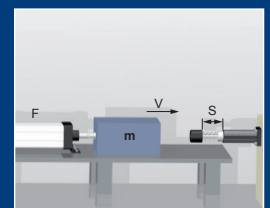

Benefits

Enlarged piston:

- Max. +400% energy
- Max. -50% costs / Nm



Piston:

- Hardened, aluminium-titanium-nitride coated

ProSurf:

- Surface protection against corrosion



Integrated stop:

- Max. security
- Easy installation

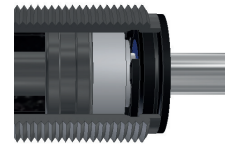

Extended life cycle:

- Nitrated guidance system
- Piston rod: hardened stainless steel
- Special seals + oils

Special models::

- Stainless steel: V4A/DIN1.4404/AISL 316L
- V4A(/DIN1.4404/AISL 316L)
- For pressure chambers up to 7 bar
- USDA-H 1 compliant for food industry
- Cleanroom

Temperature:

- Standard: -20°C - ...+80°
- Low-temperature: -50°C-...+60°C
- High-temperature: 0°C-...+120°C

Stop caps:

A:

- Standard from POM
- Increased protection of the impact surface

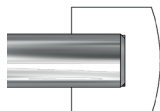

AP:

- 40% noise reduction due to PU
- Increased protection of the impact surface

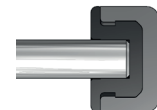

AP2:

- Longer life time compared to stop cap AP and plastic cap A due to glass fiber reinforced PU cap

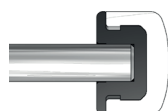

AS:

- From hardened steel
- For side forces and difficult operating conditions



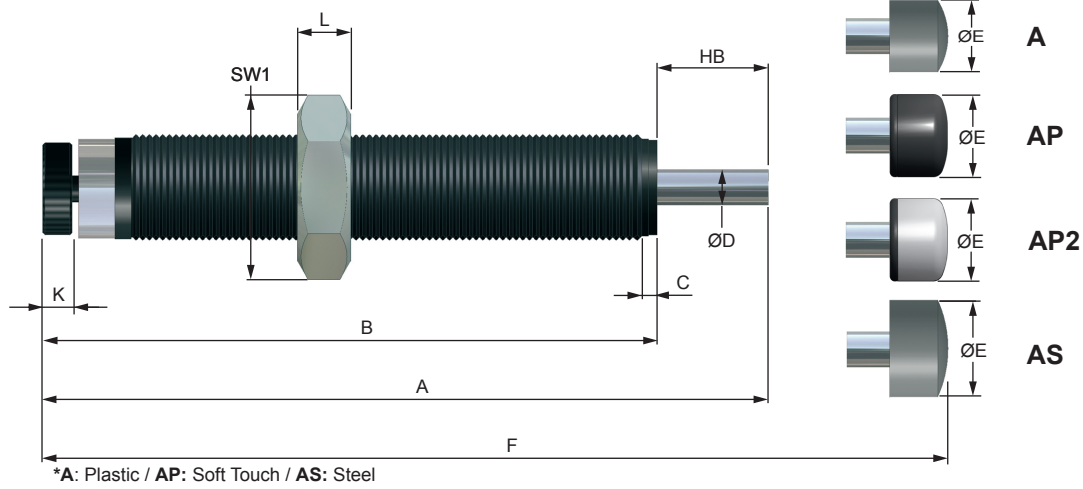

DIMENSIONS

	GW	A	B	C	ø D	øE (A)	øE (AP / AP2)	øE (AS)	F (A)	F (AP / AP2)	F (AS)	L	SW1	K
		mm	mm	mm	mm	mm	mm	mm	mm	mm	mm	mm	mm	mm
WE-M 0,1	M 8 x 1	56,0	45,0	2,5	2,5	6	6,5	-	61,5	63,0	-	3	11	3,5
WE-M 0,15	M 10 x 1	62,0	48,5	2,5	3,0	6	8,5	8,5	68,5	68,5	68,5	3	13	3,5
WE-M 0,2	M 12 x 1	81,5	66,0	2,5	4,0	10	10,0	10	89,5	90,0	89,5	4	14	3,5

SPECIAL THREAD - from stock

Series	Code	Threads	Example
0,1	U	3/8-32 UNEF	WE-M 0,1U
0,15	T	M 10x0,75	WE-M 0,15T
0,15	UF	7/16-28 UNEF	WE-M 0,15UF
0,2	UF	7 /16-28 UNEF	WE-M 0,2UF
0,2	UH	1 /2-20 UNF	WE-M 0,2UH

STAINLESS STEEL - from stock

Series	Code	Threads	Example
0,1		M 8x1	WE-M 0,1-VA
0,15		M 10x1	WE-M 0,15-VA
0,2		M 12x1	WE-M 0,2-VA

PERFORMANCE

	Stroke	Energy absorption		Effective Mass
		Constant load*		
		Nm/HB (max.)	Nm/h (max.)	min. - max.kg
WE-M 0,1	7	4	14.400	0,65 - 50
WE-M 0,15	10	15	24.000	1,0 - 500
WE-M 0,2	12	22	35.200	1,5 - 800

Technical data at + 20°C

Technical Data

Weight	0,1:	10 g
	0,15:	20 g
	0,2:	36 g
Impact speed	WE-M:	0,2 - 3,5 m/s
Return spring force	0,1:	2,5 N/min - 6 N/max
	0,15:	3,6 N/min - 8 N/max
	0,2:	3,5 N/min - 7 N/max
Torque: max. force by using the flats	0,1:	2 Nm
	0,15:	6 Nm
	0,2:	10 Nm
Housing	ProSurf	
Piston rod	Hardened stainless steel	
RoHS - compliant	Directive 2002/95/EG	
Included	1 lock nut	

Accessories

Stop limit nut

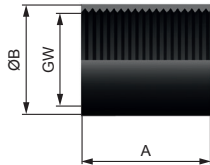

GW*	A mm	ØB mm	Code
M8x0,75	12	11	14018T
M8x1	12	11	14018
M10x1	15	14	15018
M12x1	20	16	17018
Stainless steel			
M8x1	12	11	14018VA
M10x1	15	14	15018VA
M12x1	20	16	17018VA

Rectangular flange

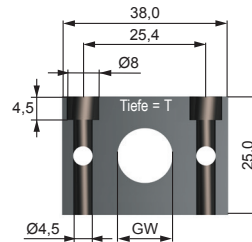

GW*	T mm	Code
M10x1	12	15013
M12x1	12	17013
Stainless steel		
M10x1	12	15013VA
M12x1	12	17013VA

Clamping flange

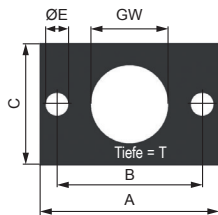

GW*	A mm	B mm	C mm	E mm	T mm	Code
M8x1	25	18	15	4,2	6	SK14013
M10x1	28	20	15	4,2	6	SK15013
M12x1	32	24	20	5,5	6	SK17013

Lock nut

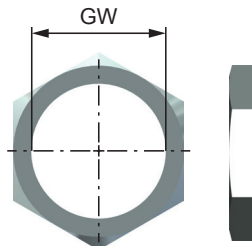

GW*	Code
M8x0,75	14012T
M8x1	14012
3/8-32 UNEF	14012U
M10x0,75	15012T
M10x1	15012
3/8-32 UNEF	15012U
7/16-28 UNEF	15012UF
M10x1	15012VA
M12x1	17012
7/16-28UNEF	17012UF
1/2-20UNF	17012UH
Stainless steel	
M8x0,75	14012T-VA
M8x1	14012VA
M10x0,75	15012T-VA
M10x1	15012VA
M12x1	17012VA

Double wiper

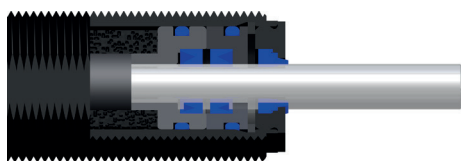

Used in applications with:

- Liquid
- Compressed air
- Dust

Solutions for Side Forces

1) AK 1

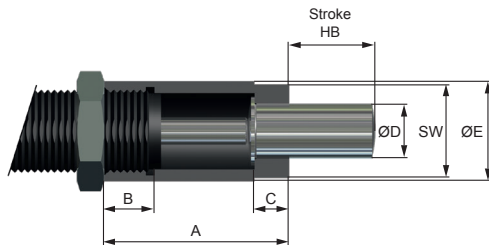

	GW*	A mm	B mm	C mm	Ø D mm	Ø E mm	SW mm	Code
0,15	M10x1	23,5	7	5	6	14	13	S20519
0,2	M12x1	25,0	7	5	9	15	14	S20619

AK 2

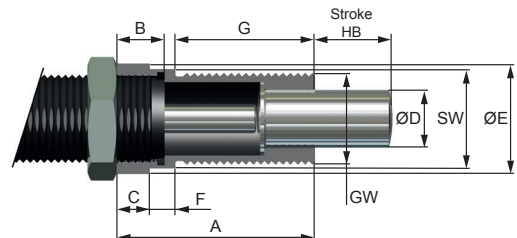

	GW*	A mm	B mm	C mm	Ø D mm	Ø E mm	F mm	G mm	SW mm	Code
M8x5	M8x1	19	7	5	4	12	4	10	10	S14119-AK2
M10x6	M10x1	22	7	5	6	14	5	12	13	S15119-AK2
M12x10	M12x1	28	7	5	7	15	5	18	14	S17019-AK2

2) WEB-M 0,1 - 0,2

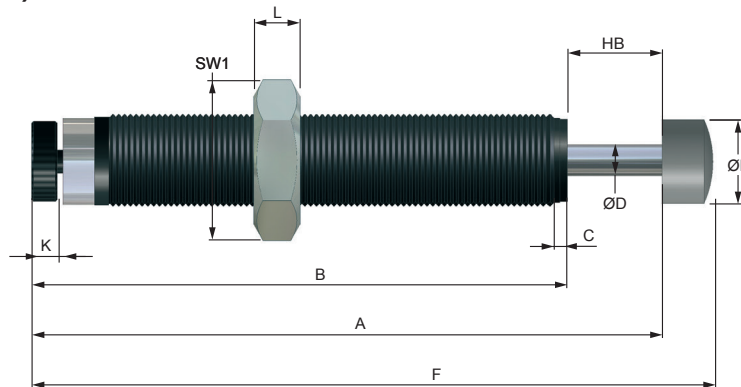

BENEFITS

Designed for side forces up to 15° without additional mounting parts; included steel stop cap

DIMENSIONS

	GW*	A	A 1	B	C	Ø D	Ø E	L	SW	SW 1
		mm	mm	mm	mm	mm	mm	mm	mm	mm
WEB-M 0,15	M 10 x 1,0	66,0	68,5	49,5	2,5	3	8,5	3	-	13
WEB-M 0,2	M 12 x 1,0	85,0	89,5	66,0	2,5	4	10	4	-	14

PERFORMANCE

	Stroke mm	Energy absorption		Effective mass					Return spring force		Torque Nm max.	Weight kg
				-0 (very soft)	-1 (soft)	-2 (medium)	-3 (hard)	-4 (very hard)				
		Nm/HB (max.)	Nm/h (max.)	min.-max.kg	min.-max.kg	min.-max.kg	min.-max.kg	min.-max.kg	min. N	max. N		
WEB-M 0,15	8	12	24000	-	1,0 - 500	-	-	-	3,6	8	6	0,02
WEB-M 0,2	10	18	36000	-	9 - 800	-	-	-	3,5	7	10	0,036

Adjustment

The damping factor is adjusted with the adjusting screw at the back-sided end of the shock absorber. The damping depends from the impact speed and the effective mass. Set possibilities on the scale 0-8

0 = low damping
8 = high damping



Adjustment: It is not allowed to adjust the shock absorber in operation conditions or during the operation. In order to adjust the shock absorber set the adjustment screw to „6“ if the velocity is <1,3 m/s or to „4“ if the velocity is >1,3 m/s. Internal damage to the shock absorber can occur, if not adjusted in gradual increments. Do not drive in the final position under full load. If the damping is not sufficient, increase continuously by rotating the adjustment to the next higher number. Maximum damping is achieved, when the highest number on the scale is reached. If the mass impacts excessively hard on the shock absorber (stop cap) the damping should be reduced by rotation of the adjustment to the next smaller number. Minimum damping is at „0“ setting. Secure the adjustment with the threaded pin. A hexagonal key is supplied for this purpose.



Installation

Installation with Lock nut

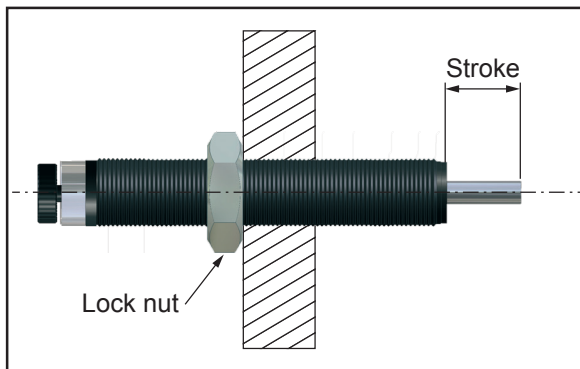

Installation with stop limit nut

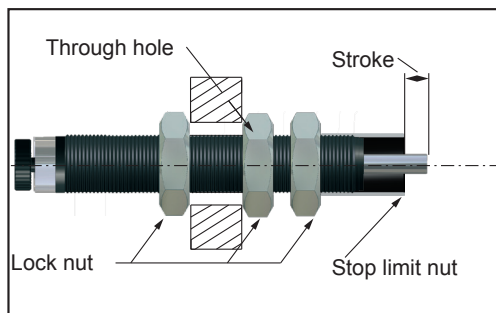

Installation with flange

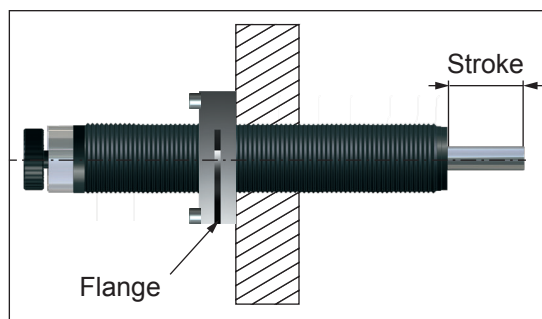

Safety Instructions

Before installation, commissioning, servicing and repair the data sheet is to be noticed. This work may only be performed by trained, introduced staff.

Electric connections according to the suitable national regulation. For Germany: VDE regulation VD E0100

Before all repair and servicing works the energy supplies (main switch, etc.) have to be switched off! Moreover, measures are necessary to prevent an unintentional reconnect. For example, a warning sign "service works" or "maintenance work", applied to the switch.

Designated use

Check before installation and make sure the type name on the shock absorber or on the packaging is corresponding with delivery note. Industrial shock absorbers are maintenance-free and ready for installation.

- Temperature influence: at higher temperatures the shock absorber characteristic will change.
- Movable loads have to be protected during the installation and maintenance against unintentional processes.
- In operation outside the allowed temperature range, the shock absorber can lose his function. Due to heat radiation don't paint the shock absorber.
- Fluids, gases and a dirty environment can affect or destroy the sealing system of the shock absorber. The result could be a failure malfunction. Piston rod and sealing system has to be protected against fluids, gases and a dirty environment.
- Damages at the piston rod can destroy the sealing system. Don't grease or oil the piston rod.
- Avoid traction forces on the piston rod to present internal damages.
- The shock absorber can be pulled out of the construction during the impact. The construction needs to be able to resist the max counterforce. Sufficient security must be calculated.
The maximum counterforces performed in the calculation program can vary from the really appearing counter forces, because these are based on theoretical values.

Fundamentals

Shock absorbers may under no circumstances be:

-painted



-welded



-held with clamps



-used on pull*



In hazardous environments (dirt, humidity, oil) shock absorbers must be protected against damage and failure with the necessary accessory. If several shock absorbers are used on the same application, the deceleration has to be distributed equally. The "Torque" (PERFORMANCE) indicates the maximum force by using the flats. The Weforma catalogue shows technical data with both minimum and maximum values. If a product is to be used in continuous operation and within a range of 20% from the minimum and maximum values shown, then written confirmation of suitability of use from Weforma is necessary.

Important information

Integrated end-stop

Up to the WE-M 0,1 - 0,2 Mega-Line series the shock absorbers are provided with an integrated end-stop. If the integrated end-stop is used the remaining energy before end of stroke must not be higher than 10% of the total energy. For all models which are used as an emergency stop an external fixed stop is necessary.

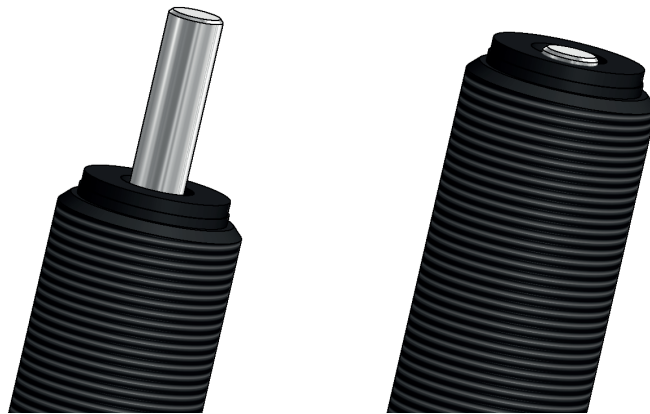

Installation situation

The installation situation is any, however always in such a way that the complete shock absorber stroke can be used. The shock absorbers must be mounted like that the forces in centerline about the piston rod are initiated. The maximum angle out of centre amounts to 3 °. With a bigger angle out of centre an AK1 / AK2 (see ``solutions for side forces´´) must be used or the shock absorber serie: WEB

Liability

Due to the number of possible uses of our products and the conditions of use that lie outside of our scope of influence, we accept no liability as to whether the purchase object is suitable for the Client's intended purpose. The verification to this effect, in particular the verification as to whether the purchase object is suitable for the planned use, is the responsibility of the Client alone, unless expressly agreed otherwise in writing.

For the reasons we accept no liability for the suitability of the purchase object for the purpose intended by the Client, except in cases of intent or gross negligence.

With damages, the not designated use and from high-handed, in these instructions do not originate to intended interventions, any guarantee and liability claim goes out towards the manufacturer.

Guarantee

By non-use of the original spare parts the guarantee claim goes out.

Environment protection

By the exchange from damaged parts is to be respected to a proper disposal.