

**HIGHLIGHTS**

- 2/2 way servo controlled
- 0,5 – 8 bar (0,5 – 10 bar upon request)
- Tap water
- Compact design
- Body valve in PPSU

PRODUCT DESCRIPTION

The new CEME Solenoid Valve for sanitary market is a 2/2 way servo controlled valve with Ø 5 mm. The main application is electronically controlled sanitary fittings, both battery driven (latching 6V) and power supply (12V DC). Thanks to the flow rate optimization, the Ø 5 mm can meet all the sanitary taps' requirements. While designing the valve, our efforts and attention were focused on the water hammer: the test results rate this valve at the top level. The hydraulic and mechanical concept has been developed considering longterm performances, durability and battery life as priority targets. All the materials are compliant with the main regulations in drinking-water applications.

DESCRIZIONE PRODOTTO

La nuova valvola CEME per il mercato sanitario è una 2/2 vie, servo comandata, con orificio DN 5 mm. L'applicazione principale è rubinetteria gestita elettronicamente, sia con alimentazione a batteria (latching 6V) che con alimentazione da rete (12V DC). Grazie all'ottimizzazione della portata, la DN 5 mm è in grado di soddisfare tutte le necessità applicative della rubinetteria.

Durante la progettazione, i nostri sforzi si sono concentrati sul colpo di ariete: i risultati dei test posizionano questa valvola ai più alti livelli di mercato. L'idraulica e la meccanica della valvola sono stati sviluppati considerando come esigenze primarie la garanzia di alte prestazioni, la resistenza nel tempo della valvola e infine un basso consumo delle batterie di alimentazione. Tutti i materiali sono in accordo con le principali normative in materia di acqua potabile.



Water Management

GENERAL FEATURES / CARATTERISTICHE GENERALI

Long life material / Materiale di lunga durata

Interchangeable plastic filter / Filtro in plastica intercambiabile

Very compact design / Design molto compatto

Low power consumption / Basso consumo energetico

Servo controlled / Servo comandato

100% tested with water and air / Testato 100 % con acqua e aria

IP grade: IP65 / Grado IP: IP65

Suitable for chemical disinfection (Chloramine) as well as thermal disinfection
Adatto per la disinfezione chimica (Chloramine), e per la disinfezione termica**MATERIALS / MATERIALI**

Body material / Materiale corpo	PPSU - R5100
LSR Seals / Guarnizione LSR	All the seals are in Liquid silicon rubber / Tutte le guarnizioni sono in Gomma siliconica liquida
Other / Altro	Stainless steel (spring and plunger) / In acciaio inox (molla e pistone)
Material approvals / Certificazioni materiale	FDA, DM174, ACS, NSF, WRAS, DVGW

SANITARY
LATCHING SOLENOID VALVE FOR SANITARY APPLICATIONS
Elettrovalvola latching per sanitari



L400 M20X1

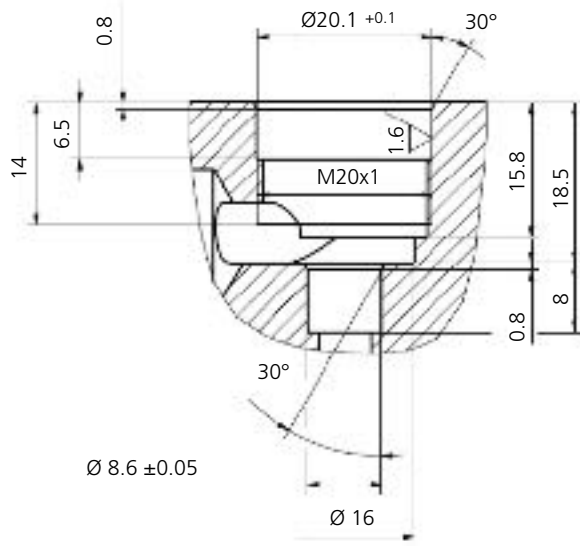
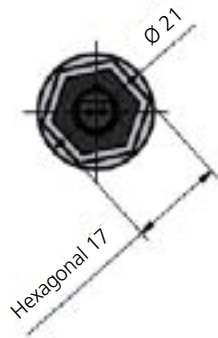

L500 M22X2

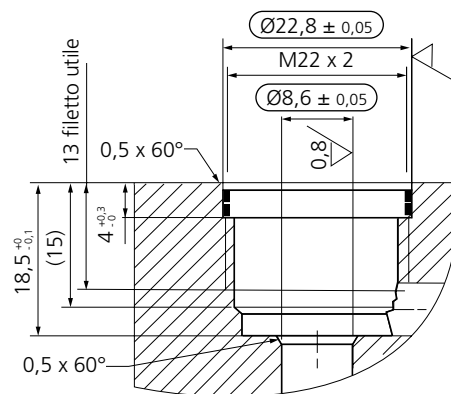
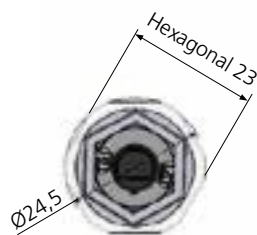
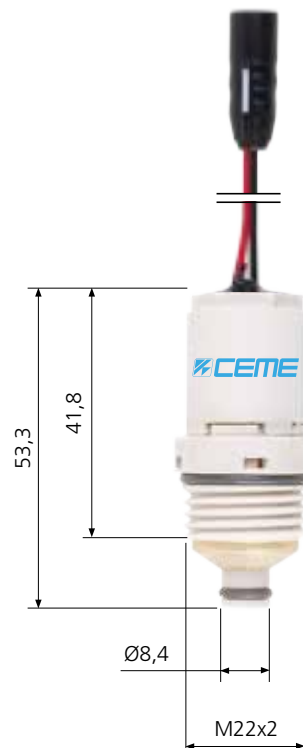

HYDRAULIC CHARACTERISTIC / CARATTERISTICHE IDRAULICHE

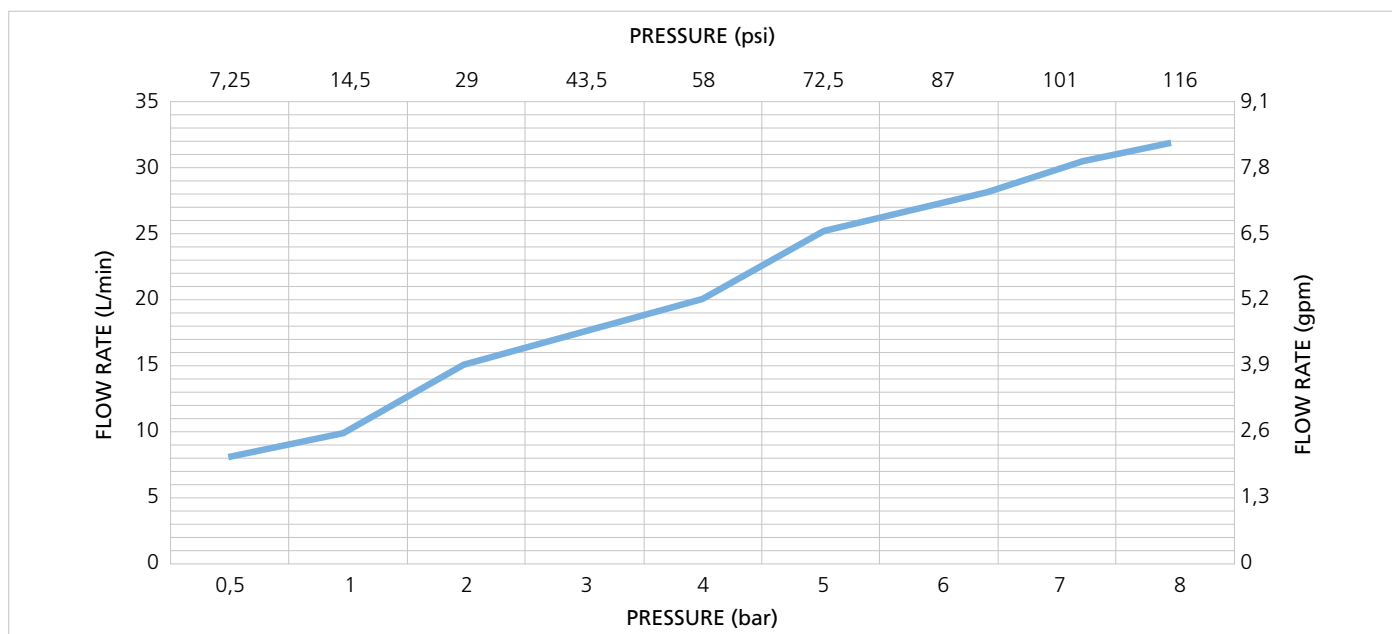

WORKING CHARACTERISTICS / CARATTERISTICHE DI LAVORO

Working pressure / <i>Pressione di lavoro</i>	0,5 ÷ 8,0 bar (7,25 ÷ 116 PSI)
Pressure burst / <i>Pressione di scoppio</i>	According to EN60730 / <i>Secondo EN60730</i>
Water Hammer / <i>Colpo d'ariete</i>	According to EN60730 / <i>Secondo EN60730</i>
Flow direction / <i>Direzione del flusso</i>	Unidirectional / <i>Unidirezionale</i>
Valve position / <i>Posizione della valvola</i>	Any position / <i>Qualsiasi posizione</i>
Working fluid / <i>Fluido di lavoro</i>	Tap water / <i>Acqua di rubinetto</i>
Power Supply / Absorption / Pulse <i>Alimentazione / Assorbimento / Impulso</i>	6V 1W 170mA Latching solenoid (impulse 15ms minimum) <i>Elettrovalvola bistabile 6V 1W 170mA (impulso 15ms minimo)</i>
Insulation class / <i>Classe di isolamento</i>	H according with EN60730 / <i>H secondo la norma EN60730</i>
Fluid Temp / <i>Temperatura fluido</i>	5° ÷ 95°C (41° ÷ 203° F)
Ambient Temp / <i>Temperatura ambiente</i>	5° ÷ 95°C (41° ÷ 203° F)

SANITARY

LATCHING SOLENOID VALVE FOR SANITARY APPLICATIONS

Elettrovalvola latching per sanitari



ELECTRICAL SPECIFICATIONS MONOSTABLE / SPECIFICHE ELETRICHE MONOSTABILE

Electrical connections / <i>Connessione elettrica</i>	Cable (KCC connector upon request) / <i>Cavo (connettore KCC su richiesta)</i>
Coil power / <i>Potenza solenoide</i>	1,5W (12V DC)
Operating voltage / <i>Tensione di funzionamento</i>	(12V DC) at 20°
Nominal Current / <i>Corrente nominale</i>	125 mA (12V DC)
ED	100%

ELECTRICAL SPECIFICATIONS LATCHING / SPECIFICHE TECNICHE LATCHING

Electrical Connection / <i>Connessione elettrica</i>	Cable (KCC connector upon request) / <i>Cavo (connettore KCC su richiesta)</i>
Coil power / <i>Potenza solenoide</i>	1W (6V)
Operating Voltage / <i>Tensione di funzionamento</i>	6V (5Vmin) at 20° C
Max Voltage supply / <i>Fornitura Max Voltage</i>	8V
Nominal Current / <i>Corrente nominale</i>	170 mA (at 6V 25°C)
Pulse time / <i>Tempo di impulso</i>	Close min 15ms / Open min 15ms

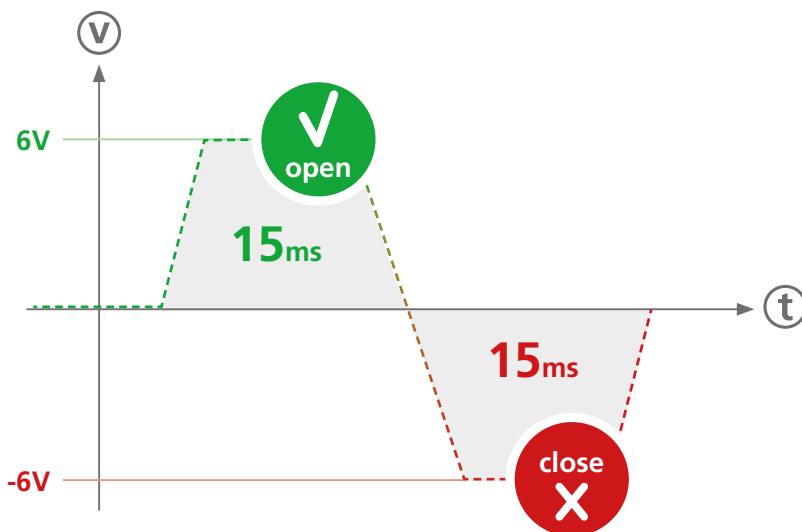

HIGHLIGHTS

The floating core system represents a unique and innovative solution in this range of valves.

Ceme R&D has concentrated his efforts to design the “springless floating system”.

This solution offers several advantages:

- Reduction of power consumption
- Faster response
- No core sticking (a very common issue with standard sanitary valves)
- Removal of a critical component.
Commonly when the core spring is damaged, the valve can remain open, wasting water from the faucet.

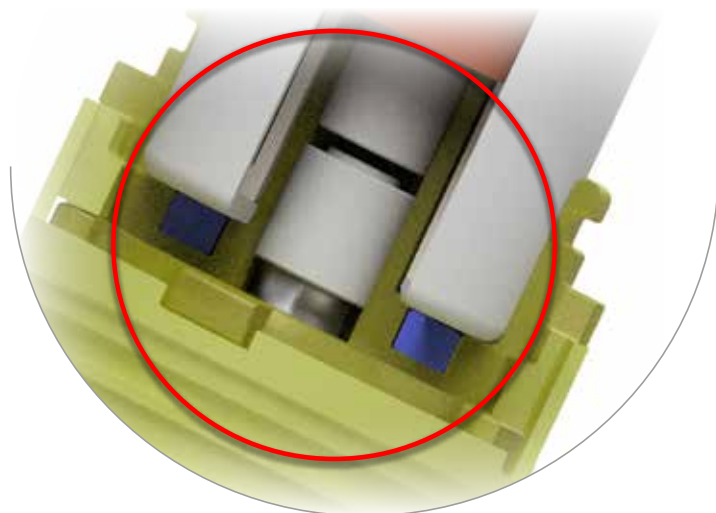

The diaphragm of this valve is a concentrate of innovation, an ambitious project that today brings many improvements if compared to standard products:

- Labyrinth Calibrated System:
The water flows through a sophisticate system of micro channels, designed to minimize the water hammer and to allow a quick and progressive closing.
- Self-cleaning:
The diaphragm has holes for the water load.
This system prevents any type of blockage due to dirt. The regular up-and-down movement of the membrane causes also a stretch deformation of the holes, keeping the passage constantly clean. This simple and smart system does not need any needle to clean the holes, unlike many other standard valves in this market.



HIGHLIGHTS

Ceme has selected one single material for all the valve seals, LSR (Liquid Silicon Rubber), instead of other common elastomers, such as EPDM.

LSR can grant far better performances:

- Fully food grade approved. LSR is also in compliance with the incoming restrictions concerning rubbers, which will involve and forbid many of the common rubbers
- Fully compatible with chloramine even in high concentration
- Fully compatible with the most common chemical agents used for disinfection
- No ageing/degradation effects - LSR assures a very long life



The body of the valve and all the internal mechanical parts are made of PPSU, one of the top high resistance plastic materials (generally common valves are made of PA66 or POM).

Also in this case, Ceme has selected this high quality material to grant the best performances:

- The high mechanical resistance rates this valve at the top level for burst pressure
- Thermal disinfection: PPSU allows the fluid compatibility at 95°C (203°F) in compliance with the most severe disinfection cycle, while the plastic materials of the common valves mentioned above, allow a max fluid temperature of 65°C (150°F), or a higher temperature just for a limited time.
- Best compatibility with food grade approvals
- Best compatibility with chemical agents
- Longer life time resistance