

## Static Electricity Removing Unit Ionizer Blow Type DTY-ELK01 Series



KOGANEI Brand

All products are **RoHS** compliant.

A wealth of variations

Simple maintenance



*Standard type*



*Low air consumption type*



*Low particle generation type*

# Ionizer Blow Type DTY-ELK01 Series

- Introducing a new type of blow type ionizer. A full lineup provides three choices, a standard type, a low air consumption type, and a low particle generation type.
- A high-frequency AC method is used for outstanding ion balance, and a wide selection of nozzles meets the needs of everything from pinpoint to wide workpiece area static charge removal.
- Controllers are also available for power and air on/off control and to enable intermittent ionized airflow.

## Simple maintenance

One-touch discharge needle unit for installation and removal.  
Allows cleaning of the entire discharge needle.

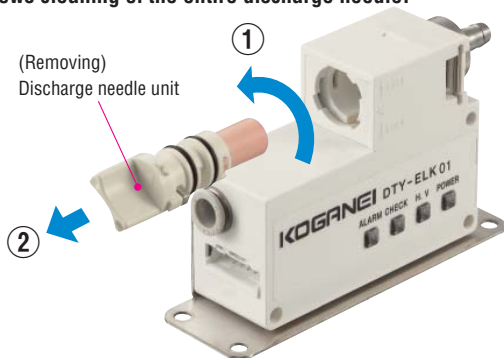

One-touch nozzle replacement.  
Set the nozzle in place and secure it with the fitting pin.

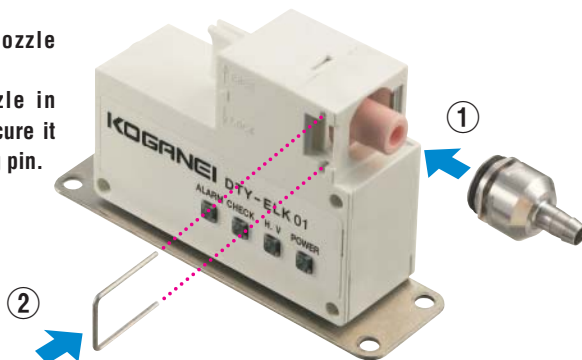

## Safe design

Discharge status and ionizer trouble can be confirmed by LED indicators and output.

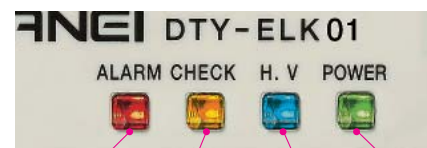

Function abnormality: Lights  
Static charge removal abnormality: Lights  
During static charge removal: Lights  
Power on: Lights

## Direct mounting of unit

The body of the unit has three mounting holes that can be used for direct mounting, for a higher level of installation flexibility.

Note: When a bracket is used, mounting holes are compatible with those of DTRY-ELL01.



## Standard Type (DTY-ELK01)

# 31 nozzle types, simple maintenance!

- Koganei Static Electricity Removing Unit Ionizers deliver a wider variety of nozzle variations plus ease of use. From pinpoint locations to wide areas, static charge removal is performed quickly and efficiently. See pages 11 through 12 for information about nozzle variations.
- An easy-to-remove discharge needle unit contributes to easier maintenance.



\* Photograph shows standard nozzle installed.



## CAUTION

Read the safety precautions on page 5 before using this product.

# Low Air Consumption Type (DTY-ELK01-S)

*Reduces expended air flow rate by 40%!* (KOGANEI comparison with DTRY-ELL01)

- Low air consumption type that suppresses expended air flow.
- Original construction suppresses expended air flow while delivering high static charge removal.
- Low air consumption standard nozzle is standard equipment.
- World's first! Supports installation of a separately available tube nozzle.



\* Photograph shows tube nozzle installed.



\* Photograph shows standard nozzle installed.

## How the low air consumption type reduces the expended air flow rate

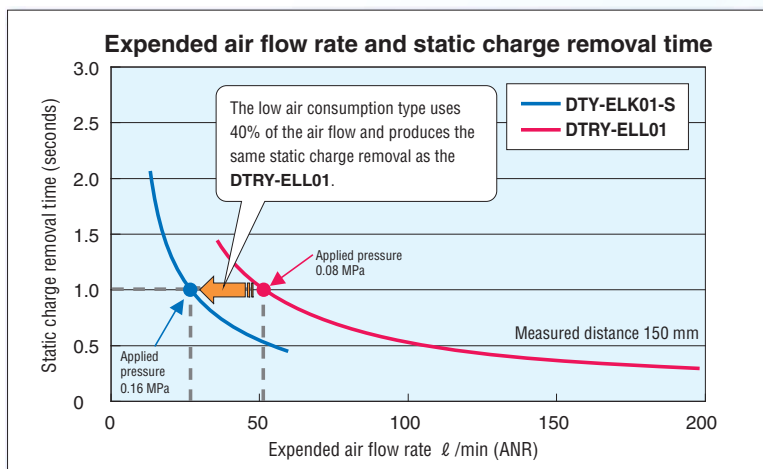

Comparing expended air flow rates, the air amplification mechanism of the low air consumption type greatly reduces the static charge removal time.

### Air amplification mechanism

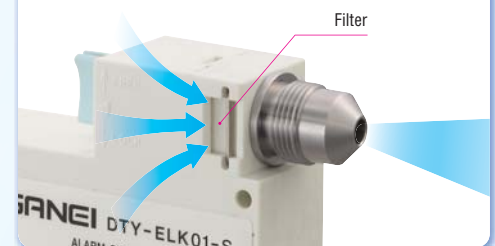

※ Applied air pressure levels for one second of static charge removal is **DTRY-ELL-1**: 0.08 MPa, **DTY-ELK01-S**: 0.16 MPa. See page 32 for information about flow rate characteristics.

※ The graph shows values when a standard nozzle is used. The same results are obtained with a tube nozzle (**DTY-NZK-03SS**).

To suppress the expended air flow rate while maintaining static charge removal performance  
(Reduced running cost)



Low air type  
**DTY-ELK01-S**

To maintain absolute flow rate and static charge removal performance  
(For particle removal, etc.)



Standard type  
**DTY-ELK01**

# Low particle generation type (DTY-ELK01-L)

## *Reducing particle generation when discharging!*

- Small, lightweight ionizer that is perfect for clean environments.
- New discharge needle (uses special alloy) minimizes needle particle generation.
- A wealth of nozzle variations designed with particle generation in mind are available.



## Amount of particle generation for low particle generation type

### ● How particle generation amounts are evaluated

KOGANEI evaluates particle generation amounts using an original measurement method that is not influenced by the measurement environment (clean bench downflow, etc.)

#### ○ Measuring methodology

All of the air blown out from the ionizer is sent directly to the particle counter and measured.

1. With the ionizer turned off, air only is supplied and particles are measured (background measurement).
2. The ionizer is turned on and particles are measured again.

#### ○ Measuring Conditions

Applied pressure: 0.1 MPa

Measurement time: 2 hours

Suction volume: 1 cf/min

Measurable particle sizes: 0.1  $\mu\text{m}$  and greater

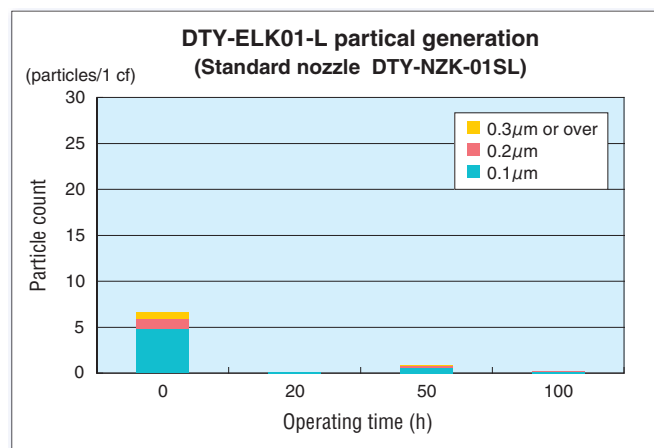

Notes 1: Total particle generation amount for two hours is converted to 1 cf (28.3  $\ell$ ).

2: This data represents actually measured values obtained by tests performed under the conditions described above. They are not guaranteed values.

The particle generation amount depends on the environment and cleanliness level. Before actually using the product, first check the environment where it will be used.

# Controller Unit (DTY-ZKCRU)\*

## Integrated on/off control of power supply and supply air!

\* For use with DTY-ELK01 Series only. Cannot control other blow types.

- Using a controller unit enables integrated on/off control of power supply and supply air using an external signal.
- Controller settings can be configured for intermittent (5 Hz or 10 Hz) blowing of ionized air. Intermittent ionized air blowing increases particle removal.
- Cleaning timer to alert you to how much ionizer operation time is available. LED lamp and output alert you when operation time reaches 300 hours or 500 hours, which can be used as a guide for cleaning. For details, see page 9 .

\* Cleaning period depends on the operating environment.



## Control unit usage example

- **Static electricity monitoring using an EP sensor and EP monitor, and ionizer control using a controller unit**

EP monitor switch output connects to the controller SIGNAL terminal for ionizer discharge and air on/off control.

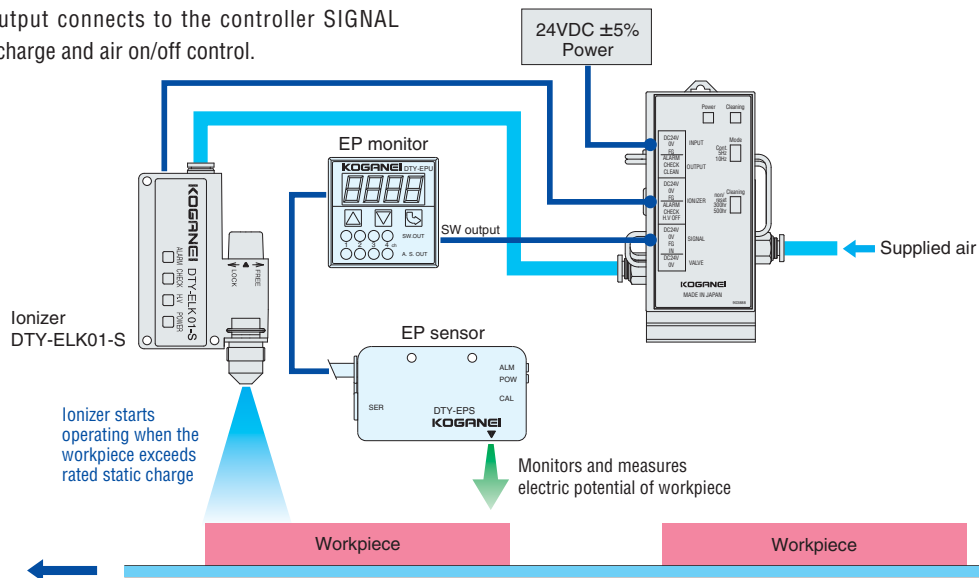



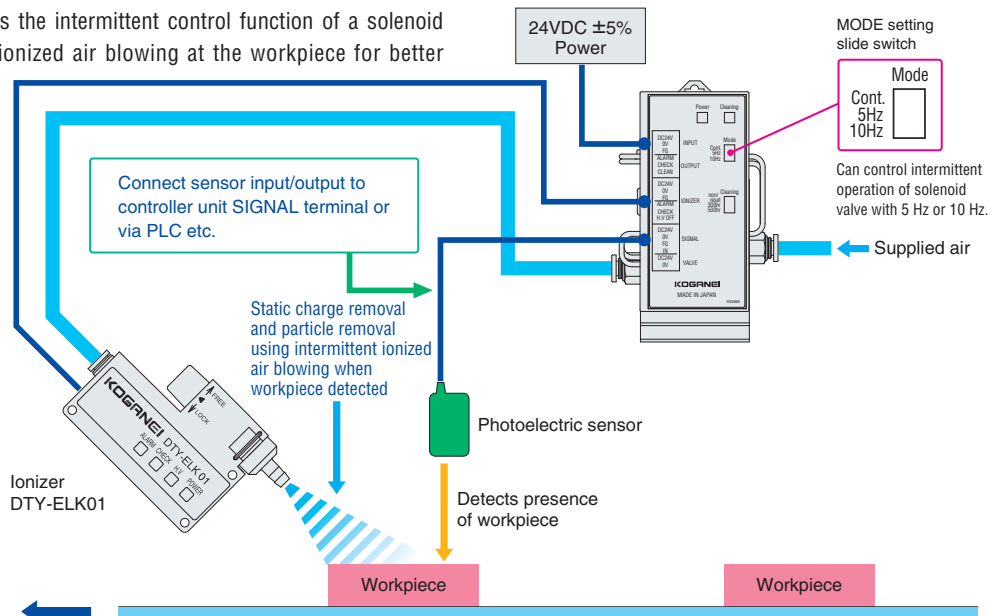

- **Static charge removal and particle removal using intermittent ionized air blowing**

The controller unit uses the intermittent control function of a solenoid valve for intermittent ionized air blowing at the workpiece for better particle removal.



Before selecting and using the products, please read all the Safety Precautions carefully to ensure proper product use. The Safety Precautions described below are to help you use the product safely and correctly, and to prevent injury or damage to you, other people, and assets. Be sure to follow both ISO4414 (Pneumatic fluid power - Recommendations for the application of equipment to transmission and control systems) and JIS B8370 (Pneumatic system regulations) safety regulations.

**The directions are ranked according to degree of potential danger or damage: DANGER!, WARNING!, CAUTION!, and ATTENTION!**

 <b>DANGER</b>	Indicates situations that can be clearly predicted as dangerous. Death or serious injury may result if the situation is not avoided. It could also result in damage or destruction of assets.
 <b>WARNING</b>	Indicates situations that, while not immediately dangerous, could become dangerous. Death or serious injury may result if the situation is not avoided. It could also result in damage or destruction of assets.
 <b>CAUTION</b>	Indicates situations that, while not immediately dangerous, could become dangerous. Failure to avoid the situation creates the risk of minor or mildly serious injury. It could also result in damage or destruction of assets.
 <b>ATTENTION</b>	While there is little chance of injury, this content refers to points that should be observed for appropriate use of the product.

- **This product was designed and manufactured as a part for use in general industrial machinery.**
- In the selection and handling of the equipment, a system designer or other person with sufficient knowledge and experience should always read the Safety Precautions, catalog, instruction manual and other literature before commencing operation. Making mistakes in handling is dangerous.
- After reading the catalog, instruction manual, etc., always place them where they can be easily available for reference to users of this product.
- If transferring or lending the product to another person, always attach the catalog, instruction manual, etc., to the product where they are easily visible, to ensure that the new user can use the product safely and properly.
- The danger, warning and caution items listed under these "Safety Precautions" do not cover all possible cases. Read the catalog and instruction manual carefully, and always keep safety first.

## **DANGER**

- Do not use the product for the purposes listed below:
  1. Medical equipment related to maintenance or management of human lives or bodies.
  2. Machines or equipment designed for the purpose of moving or transporting people.
  3. Critical safety components in mechanical devices.
 This product has not been planned or designed for purposes that require high levels of safety. Using it in this way may result in loss of human life.
- Do not use the product in locations with or near dangerous substances such as flammable or ignitable substances. This product is not explosion-proof. It could ignite or burst into flames.
- When mounting the product and nozzles, always firmly support and secure them in place. Falling, dropping, or abnormal operation etc of the product, may result in injury.
- Persons who use a pacemaker, etc., should keep a distance of at least one meter away from the product. There is a possibility that the pacemaker will malfunction due to the magnetic field, etc.
- Never attempt inappropriate disassembly or assembly of the product relating to basic construction, or to its performance or functions. Doing so creates the risk of abnormal operation, injury, electric shock, fire, etc.
- Do not allow water to splash on the product. Water spraying on the product, washing it, or using it under water creates the risk of abnormal operation, leading to injury, electric shocks, fire, etc.
- Always turn off power before inspecting or cleaning the product, or performing maintenance. Failure to do so creates the risk of electric shock.
- Never attempt to modify the product in any way. Doing so creates the risk of abnormal operation, leading to injury, electric shocks, fire, etc.

## **WARNING**

- Do not use the product in excess of its specification range. Such use could result in product breakdowns, function stops, or damage. It could also drastically reduce the product's operating life.
- Be sure to fully implement shielding measures whenever using the product in the locations described below. Failure to do so creates the risk of abnormal operation, damage to machinery, or personal injury.
  1. Locations subject to large electric currents or strong magnetic fields
  2. Locations that may be subject to exposure from radioactive emission.
- Use safety circuits or create system designs that prevent damage to machinery or injury to personnel when the machine is shut down due to an emergency stop or electrical power failure.

- Do not share or wire parallel to power or high voltage lines. Noise from these lines may cause the equipment to operate erratically.
- Before supplying electricity to the device and before starting operation, always conduct a safety check of the area of machine operation. Unintentional supply of electricity creates the risk of electric shock.
- Do not touch the discharge needle, terminals, or switches, while power is turned on. There is a possibility of electric shocks and abnormal operation.
- Do not allow the product to be thrown into fire. The product could explode and/or release toxic gases.
- Do not sit on the product, place your foot on it, or place other objects on it. Tripping over or dropping the product may result in injury, damage or breakage to the product resulting in abnormal, erratic, or runaway operation, etc.
- Before conducting any kind of product inspection, maintenance, or replacement, be sure to completely cut off the power supply.
- Before performing any kind of wiring work, be sure to turn off power. Failure to do so creates the risk of electric shock.
- Do not allow the power cord, lead wires, and other cords to become damaged. Allowing a cord to become cut, bent excessively, pulled, rolled up, placed under a heavy object, or squeezed between two objects creates the risk of current leaks or defective continuity that can lead to fire, electric shock, or abnormal operation.
- Do not connect or disconnect connectors while power is turned on. Also, never apply unnecessary force to connectors. Doing so creates the risk of personal injury, device damage, and electric shock due to abnormal machine operation.
- Always refer to the instruction manual and other documentation for information about proper product wiring and piping. Improper wiring and piping creates the risk of damage and abnormal operation.
- After completing wiring work, check to make sure that all connections are correct before turning on power.
- Correctly apply the rated voltage to the product. Applying the wrong voltage will make it impossible to obtain the specified function, and creates the risk of damage to and burnout of the product.
- Do not place the AC adapter cable, or the power or signal wires of the products on moving parts because there is a risk they may be severed.
- Should you ever notice smoke, strange odors, or noise being emitted, stop using the equipment. Continued use creates the risk of fire and electric shock.

## **CAUTION**

- Do not use the product in locations subject to direct sunlight (ultraviolet rays), dust, salt, iron particles, or humidity, or in ambient

atmospheres that include organic solvents, phosphate ester type hydraulic oil, sulfur dioxide gas, chlorine gas, acids, etc. Doing so could lead to loss of function, sudden degradation of performance, and reduced service life.

- This product uses sensitive electronic components. When handling the product take care to avoid dropping it, allowing it to come into contact with other objects, or otherwise subjecting it to excessive impact. Even if the product appears undamaged, damage to internal components can cause abnormal operation.
- When installing the product, be sure to allow adequate work space around it. Failure to ensure adequate work space will make it more difficult to conduct daily inspections or maintenance, which could eventually lead to system shutdown or damage to the product.
- Always post an "operations in progress" sign for installations, adjustments, or other operations, to avoid unintentional supplying of electrical power, etc. Unintended power supply can cause electric shock and sudden operation, creating the risk of personal injury.

### ATTENTION

- When considering the possibility of using this product in situations or environments not specifically noted in the catalog or instruction manual, or in applications where safety is an important requirement such as in an aircraft related facilities, combustion equipment, leisure equipment, safety equipment, and other places where human life or assets may be greatly affected, take adequate safety precautions such as allowing plenty of margin for ratings and performance, or fail-safe measures. Be sure to consult with us regarding such applications.
- Always check the instruction manual and other reference materials for product wiring and piping.
- When handling the product, wear protective gloves, safety glasses, safety shoes, etc. for protection.
- When the product can no longer be used, or is no longer necessary, dispose of it appropriately as industrial waste.
- Equipment may exhibit degraded performance and function over its operating life. Always conduct daily inspections of the equipment, and confirm that all requisite system functions are satisfied, to prevent accidents from happening.

### Other

- When using this product in a system, use only genuine KOGANEI parts or equivalent (recommended) parts.  
When conducting maintenance and repairs, always use genuine KOGANEI parts or equivalent parts (recommended parts).  
Always observe the prescribed methods and procedures.

KOGANEI cannot be responsible if these items are not properly observed.

## Blow Type Ionizer Safety Precautions

### DANGER

- High voltage is applied to the discharge needle, creating the risk of electric shock. Never touch the discharge needle while power is turned on.

### WARNING

- The tip of the discharge needle is a sharp point. Care is required when handling the needle. Improper handling of the discharge needle creates the risk of personal injury.
- Before conducting any kind maintenance, inspection, repair, connecting, disconnecting, or replacing parts, or similar operations on a product that uses pressurized air, always be sure first to completely cut off the air supply and confirm that residual pressure inside the product or in piping connected to the product is zero. In particular, be aware that residual air will still be in the air compressor or air storage tank.
- Blow type ionizers use air as a medium. Do not use any other type of medium.
- In the case of a blow type ionizer, always apply air first before applying power. Applying power while air is not being applied creates the risk of adversely affecting machinery and the environment.
- Check to make sure that the discharge needle unit is locked before applying air.

### CAUTION

- An ionizer emits ozone into the atmosphere. Use of a single unit will cause ozone to reach the saturation point and will not increase past a fixed level. When using multiple units at the same time, provide ventilation if the odor of ozone becomes noticeable. Do not try to check for ozone odor by bringing your face close to the ionized air flow outlet. Doing so injure your nose and throat.
- Never try to use an ionizer for any other purpose beside static charge removal.
- Before performing piping work, thoroughly flush the inside of the pipes with compressed air. Metal chips, sealing tape, and rust generated while performing piping work create the risk of clogging and malfunction.
- For the medium, use clean air that does not include any oil or water.
- This product cannot be used if the medium or ambient atmosphere includes any of the following substances: Organic solvents, phosphate type hydraulic oil, sulfur dioxide gas, chlorine gas, or acids.
- Static charge removal may not be possible by ion blowing if there is a charged object in the vicinity of or touching another object. Pay attention to the environment surrounding the static charge removal target when setting up the ionizer.
- Static charge removal performance is reduced if the ionizer is not fully grounded.
- The life of the discharge needle depends on operating environment conditions. Periodic maintenance is required because performance is reduced under bad operating environment conditions (high humidity, etc.) or if the discharge needle is not cleaned.
- Note that inrush current occurs when power is turned on. When power on/off is controlled by PLC or other means, control using H.V. OFF.

## Handling Instructions and Precautions



### General Precautions

1. Do not apply extreme force to the exterior of the product.
2. Do not disassemble or modify the product.
3. Do not expose the product to ultraviolet rays, wind, or rain.

### Mounting

1. Install the product on a flat surface. Twisting or bending during mounting creates the risk of abnormal operation.
2. For machine installation, take care to avoid water, oil, high temperatures, and high humidity. Be especially careful to avoid locations that are subject to condensation.

### Wiring

1. When using a power supply with a commercially available switching regulator, be sure to connect a frame ground (F.G.).
2. When using devices that generate noise (switching regulator, inverter motor, etc.) in the vicinity of the installation, be sure to connect a frame ground (F.G.) to the devices.
3. After completing wiring work, check to make sure that all connections are correct.

### Precautions During Use

1. Always turn off power before doing inspection, cleaning, or maintenance work.
2. Should any malfunction occur, be sure to contact KOGANEI for adjustment and repair.
3. Periodic maintenance is important to maintain performance. Perform periodic maintenance according to the instructions in the product's instruction manual.
4. Do not use the product in the moving section of a machine where there is vibration or shock.
5. Do not place the AC adapter cable, or the power or signal wires of the products on moving parts because there is a risk they may be severed.

# Handling Instructions and Precautions

## Precautions During Use

1. In the case of a blow type ionizer, always apply air first before applying power. Applying the power supply while air is not being applied will cause discharge, which raises the internal ozone density and creates the risk of adverse effect to the machine and environment.
2. Perform ionizer power on/off on the input power supply (+24VDC) side.
3. When using the **DTY-NZK-H□□** tube tip nozzle, connect the tube tip nozzle (included bracket) to ground. Failure to do so may prevent peak ionizer performance.
4. Nozzle tubes are consumables, so they required periodic replacement when they become soft or when they deteriorate.
5. Use only KOGANEI nozzles. Never attempt to modify nozzles. Doing so creates the risk of product malfunction, loss of function, or damage.
6. When bending a bender nozzle, hold the bender nozzle at its base. Failure to do so can result in damage to the pipe and the unit connector portion.

## Output of abnormality output contact point

1. The abnormality output circuit of this product will normally activate about one second after power is turned on. Sufficient care should be taken to design an error detection circuit at the time of the unit installation on other equipment, etc.
2. Abnormality output is performed if power to the ionizer unit is turned off and immediately turned back on again. After turning power off, wait for at least one second before turning power back on again.
3. Abnormality output may be performed when power to the ionizer unit is turned off. Sufficient care should be taken to design error detection circuitry that does not detect ionizer error output for one second after power to the ionizer unit is turned off.

Notes 1: The same also applies when the ionizer is turned on and off by H.V OFF.

2: Neither of the cases above causes any problems with ionizer performance.

## Installing a nozzle unit for a bender nozzle

To install a nozzle unit on the tip of the **DTY-NZK-□00D**, first remove the bender nozzle tip component and then install the nozzle unit. Securely screw the nozzle unit onto the bender nozzle.

For direction adjustment of the ionized air flow outlets of the **DTRY-ADN-□00B** bender bar nozzle unit, loosen nut B. At this time, secure the bender nozzle with nut A in order to prevent force from being applied to the bender nozzle.

For direction adjustment of the ionized air flow outlets of the **DTRY-ADN-FT01** bender flat nozzle unit, perform adjustment at the tip and secure with the lock nut.

- Caution**
1. Before installing or replacing a nozzle unit for a nozzle or bender nozzle, be sure to turn power and air off.
  2. The recommended tightening torque of the nozzle unit for bender nozzles is 30 N-cm.
  3. The recommended tightening torque for nut B and the lock nut is 70 to 90 N-cm.

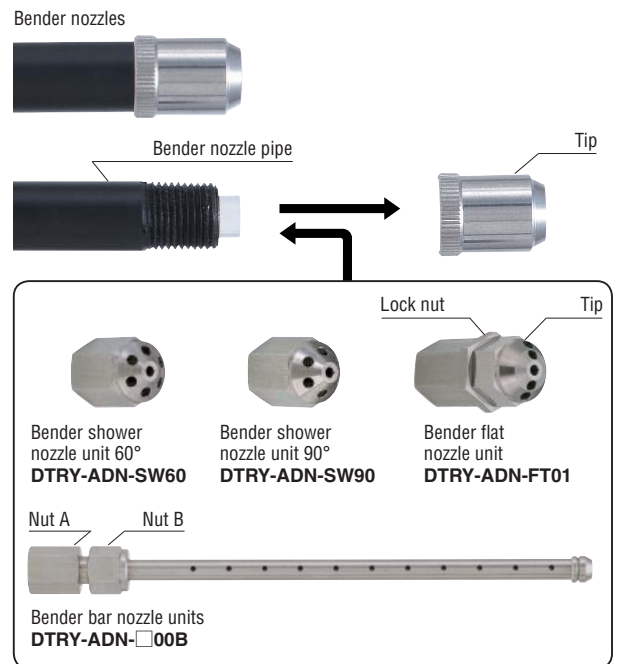

## Minimum bending radius of bender nozzles and tubes

mm	
Model	Minimum bending radius
<b>DTY-NZK□00D/DTY-NZK□00DL</b>	40
<b>DTRY-ADN-U</b>	15
<b>DTRY-ADN-F</b>	50
<b>DTRY-ADN-S</b>	10
<b>DTY-ZKTL</b>	10

**Caution** Static charge removal performance may be reduced during use at the minimum bending radius.

## CAUTION

- In the case of a blow type ionizer, always supply air first before applying power. Applying power while air is not being supplied creates the risk of adversely affecting machinery and the environment.
- For the medium, use clean air that does not contain any oil.



# Specifications

## Blow Type DTY-ELK01 Series

Item	Model	DTY-ELK01 (Standard Type)	DTY-ELK01-S (Low Air Consumption Type)	DTY-ELK01-L (Low Particle Generation Type)
Power supply		24VDC ±5%		
Consumption current	mA	Approximately 70		
Output voltage	kV	Approximately 2 (high-frequency type)		
Indicators	POWER LED (green)	Lights while power is on		
	H.V LED (blue)	Lights during discharge		
	CHECK LED (yellow)	Lights when a discharge abnormality occurs (H.V LED off)		
	ALARM LED (red)	Lights when a machine abnormality occurs (H.V LED off)		
Output		Contact output when CHECK LED or ALARM LED is lighted (24VDC 50 mA MAX. open drain)		
Ionizer ON/OFF control input		Discharge stop by short circuit with 0V (no voltage input, internal drop voltage of 0.5V or less)		
Ion balance	V	Within ±15 (standard nozzle; 50 mm [2 in.] from nozzle tip; supply air pressure: 0.3 MPa [44 psi.])		
Static charge removal time <sup>Note 1</sup>	seconds	0.5 or less	0.8 or less	0.5 or less
Ozone generation amount	ppm	0.03 or less (standard nozzle; 300 mm [11.8 in.] from nozzle tip; supply air pressure: 0.3 MPa [44 psi.])		
Particle generation amount <sup>Note 2</sup>	particles	—	—	50 or less
Medium		Air (clean air, water vapor and oil removed)		
Operating air pressure range	MPa [psi.]	0.05~0.5 [7~73]		
Expanded air flow rate <sup>Note 3</sup>	ℓ /min [ft <sup>3</sup> /min] (ANR)	260 [9.2]	60 [2.1]	260 [9.2]
Mass	g [oz.]	60 [2.12] <sup>Note 4</sup>	75 [2.65] <sup>Note 5</sup>	66 [2.33] <sup>Note 4</sup>
Operating environment		Indoors: 0 to 40°C [32 to 104°F], 15 to 65% RH (non-condensation)		
Accessories		Power and signal cable (2 meters), bracket		

Notes 1: Standard nozzle; measuring distance: 50 mm [2 in.]; supply air pressure: 0.1 MPa [14.5 psi.]

2: Particle diameter: 0.3 μm or greater at 1 cf/min. Actual measured values, not guaranteed values.

3: Air supply pressure: 0.5 MPa [73 psi.].

4: When bracket and nozzle are not installed.

5: Bracket not equipped.

Remark: Ion balance and static charge removal time are measured according to KOGANEI measurement conditions. Contact KOGANEI for details.

## Controller (DTY-ELK01 series only)

Item	Model	DTY-ZKCR (Controller)	DTY-ZKCRU (Controller unit)
Power supply		24VDC ±5%	
Consumption current <sup>Note 1</sup>	mA	50	230
Control input <sup>Note 2</sup>		No voltage input, internal drop voltage of 0.5V or less	
Output	ALARM	Ionizer output through	
	CHECK	(open drain 24VDC 50 mA MAX.)	
	CLEAN	Open collector output 24VDC 50 mA MAX.	
Solenoid valve connection <sup>Note 3</sup>		24VDC (200 mA MAX.)	—
Settings	MODE (solenoid valve operation setting)	Cont. (continuous operation), 5 Hz (intermittent operation), 10 Hz (intermittent operation)	
	Cleaning <sup>Note 4</sup> (timer setting)	non/reset (not using or timer reset) 300 hr (ionizer operation time: 300 hours) 500 hr (ionizer operation time: 500 hours)	
Indicators	Power LED (red)	Lights while power is on	
	Cleaning LED (red)	Lights when cleaning timer time setting is reached.	
Piping diameter		—	φ 6 quick fitting (IN, OUT)
Operating pressure range	MPa [psi.]	—	0.05~0.5 [7~73]
Medium		—	Air (clean air, water vapor and oil removed)
Built-in Solenoid valve	Model	—	130E1-2-SR-4W DC24V (direct drive type, low grease specification, surge protected)
	Flow rate characteristics	—	Sonic conductance C: 0.96 dm <sup>3</sup> (s · bar), Effective area: 4.8 mm <sup>2</sup> [Cv: 0.27]
	Port size	—	Rc 1/8
	Operating pressure range MPa [psi.]	—	0~0.9 [0~131] <sup>Note 5</sup>
	Maximum operating frequency Hz	—	10
	Current value mA	—	185
Mass	g [oz.]	60 [2.12]	250 [8.82]
Mounting methods		DIN rail mounting	Bracket mounting
Operating environment		Indoors: 0 to 40°C [32 to 104°F], 35 to 65% RH (non-condensation)	

Notes 1: Ionizer and externally connected equipment not included.

2: Use a control input OFF time of 200 ms or greater.

3: Capacity of connectable solenoid valve. For the solenoid valve, use a direct drive valve. Use a valve with surge protection and one that uses little grease.

4: The ionizer cleaning period depends on the operating environment. Use the cleaning timer as a guideline.

5: Use within the ionizer operating pressure range.

Reference: The DTY-ZKCRU (controller unit) is a unit product of DTY-AKCR (controller) and solenoid valve. Depending on operating conditions, the life of the solenoid valve may differ from that of the ionizer.



1. When using a low particle generation type, note that particles may be generated from the solenoid valve.

2. When performing intermittent operation, the desired intermittent air effect may not be obtainable if the piping distance from the solenoid valve to the ionizer is long.

# Controller connection configuration and functions

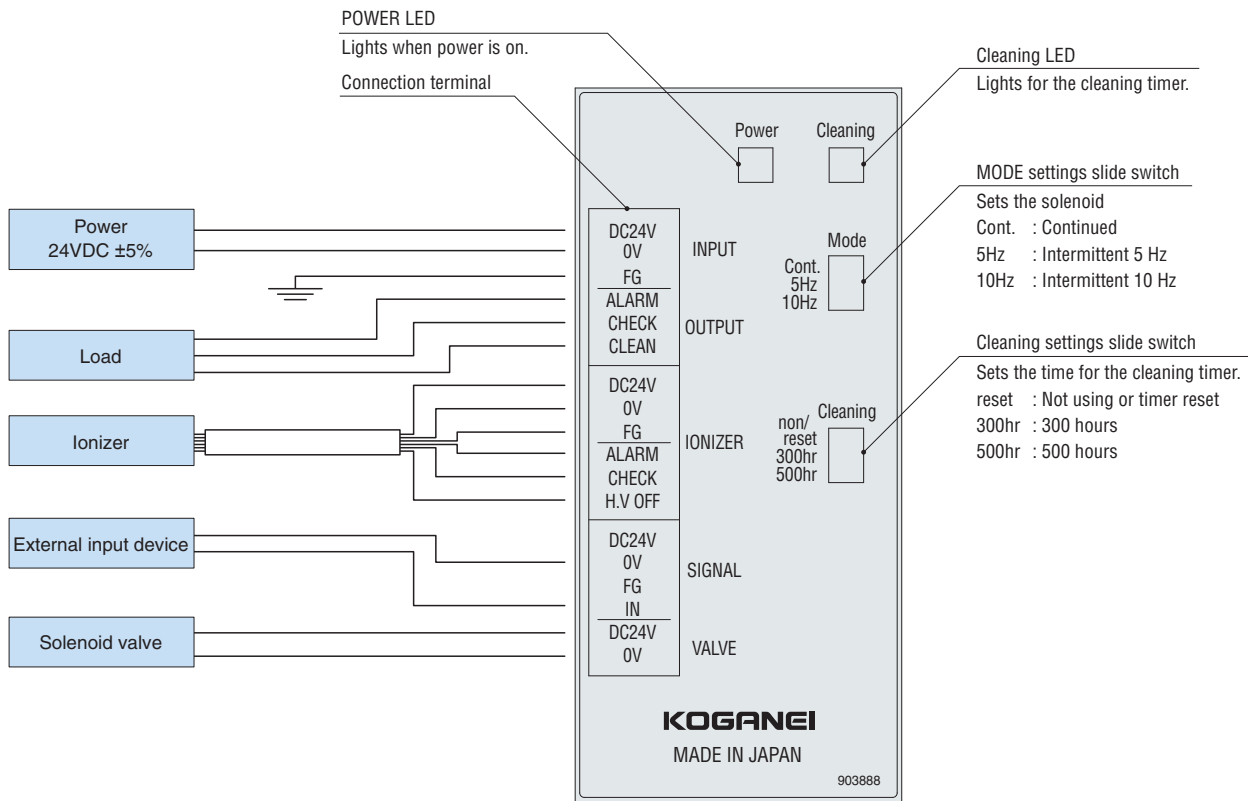

Note: Always be sure to connect the IONIZER H.V OFF terminal.

Reference: Recommended solenoid valve: **130E1-2-SR-4W DC24V** (direct drive type; low grease specifications; surge protected). Depending on operating conditions, the life of the solenoid valve may differ from that of the ionizer.

## Connection terminal functions

Terminal Name		Function
INPUT	DC24V	Inputs 24VDC ±5% power supply
	0V	
	FG	
OUTPUT	ALARM	Performs abnormality output from ionizer and check output signal.
	CHECK	
	CLEAN	
IONIZER	DC24V	Supplies power to the ionizer.
	0V	
	FG	For connection of ionizer ground.
	ALARM	For connection of the ionizer abnormality signal line.
	CHECK	For connection of the ionizer check signal line.
	H.V OFF	Controls ionizer discharge on/off.
SIGNAL	DC24V	For connection of switch, sensor, or other external input device. The ionizer and solenoid valve operate while a signal is being input from a device.
	0V	
	FG	
	IN	
VALVE	DC24V	Operates the solenoid valve.
	0V	

## OUTPUT terminal circuit configuration

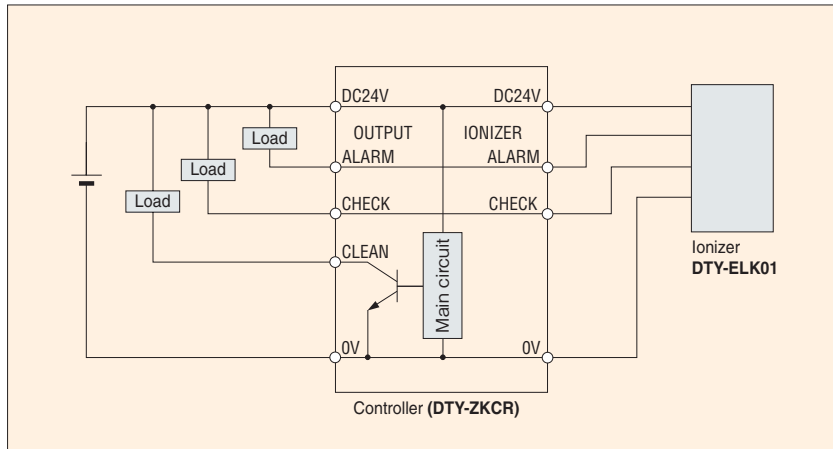

## SIGNAL terminal external connection example

### ● Reed switch output type

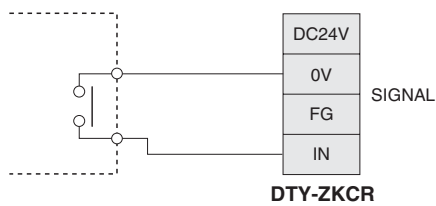

### ● NPN open collector output type

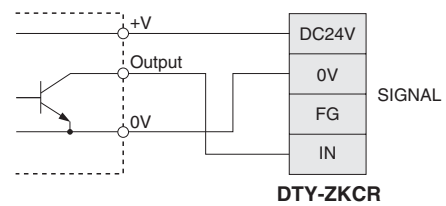

### ● For EP sensor + EP monitor

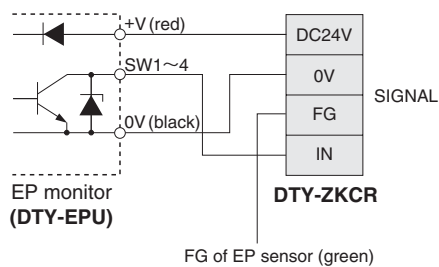

# Order Codes

## Blow Type DTY-ELK01 (Standard Type)

### Main Unit

- 1-Head Type  
DTY-ELK01

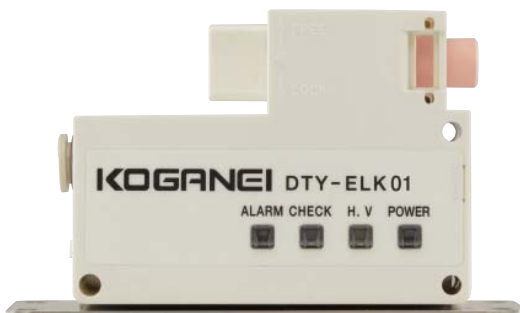

**Caution** Main unit cannot be used alone.  
Always use it in combination with a nozzle.

### Standard Type Nozzles

**Caution** Cannot be used with a low particle generation type or low air consumption type.

- Standard nozzle  
DTY-NZK-01S



\* Fixing pin included

- Flat nozzle  
DTY-NZK-FT



\* Fixing pin included

- Pipe nozzle  
DTY-NZK-02S



\* Fixing pin included

- Bender nozzles

**DTY-NZK-100D** (Nominal dimension: 100 mm)  
**DTY-NZK-200D** (Nominal dimension: 200 mm)  
**DTY-NZK-300D** (Nominal dimension: 300 mm)  
**DTY-NZK-400D** (Nominal dimension: 400 mm)  
**DTY-NZK-500D** (Nominal dimension: 500 mm)



\* Fixing pin included

Reference: For information about bender nozzle minimum bending radius, see page 7.

- Straight bar nozzles

**DTY-NZK-100B** (Nominal dimension: 100 mm)  
**DTY-NZK-200B** (Nominal dimension: 200 mm)  
**DTY-NZK-300B** (Nominal dimension: 300 mm)  
**DTY-NZK-400B** (Nominal dimension: 400 mm)  
**DTY-NZK-500B** (Nominal dimension: 500 mm)



\* Fixing pin included

- U-shaped bar nozzle  
DTY-NZK-100U



\* Fixing pin included

- L-shaped bar nozzles

**DTY-NZK-100L**  
(Nominal dimension: 100 mm)  
**DTY-NZK-200L**  
(Nominal dimension: 200 mm)



\* Fixing pin included

- Free-mounting L-shaped bar nozzles

**DTY-NZK-100FMT**  
(Nominal dimension: 100 mm)  
**DTY-NZK-200FMT**  
(Nominal dimension: 200 mm)



\* Fixing pin included

- Spiral bar nozzle  
DTY-NZK-200SP



\* Fixing pin included

- Shower nozzles

**DTY-NZK-60SW** (60° type)  
**DTY-NZK-90SW** (90° type)



\* Fixing pin included

## Blow Type DTY-ELK01 (Standard Type)

### Standard Type Options (sold separately)

● Bender shower nozzle units

**DTRY-ADN-SW60** (60° type)  
**DTRY-ADN-SW90** (90° type)



● Bender flat nozzle units

**DTRY-ADN-FT01**



● Bender bar nozzle units

**DTRY-ADN-100B** (Nominal dimension: 100 mm)  
**DTRY-ADN-200B** (Nominal dimension: 200 mm)



● Tube tip shower nozzle units

**DTY-NZK-H60SW** (60° type)  
**DTY-NZK-H90SW** (90° type)



\* Two fixing screws included

● Tube tip flat nozzle units

**DTY-NZK-HFT**

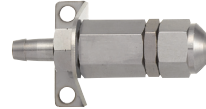

\* Two fixing screws included

● Tube tip bar nozzle units

**DTY-NZK-H100B** (Nominal dimension: 100 mm)  
**DTY-NZK-H200B** (Nominal dimension: 200 mm)



\* Two fixing screws included

● Conductive urethane tube (500 mm)

**DTRY-ADN-U**  
 Outer diameter:  $\phi 6$   
 Inner diameter:  $\phi 4$   
 Color: Black

● Silicon tube (500 mm)

**DTRY-ADN-S**  
 Outer diameter:  $\phi 7$   
 Inner diameter:  $\phi 4$   
 Color: Black

● Teflon tube (500 mm)

**DTRY-ADN-F**  
 Outer diameter:  $\phi 7$   
 Inner diameter:  $\phi 5$   
 Color: Black

Notes 1: Tubes are consumables and require periodic replacement.

2: For use with ionizers only. Do not use for pneumatic equipment piping.

Remarks 1: Use Teflon tubes to maximize service life, or silicon tubes to maximize bendability.

2: For information about minimum bending radius see page 7.

3: Conductive urethane tube is available in 20-meter and 100-meter rolls.

Order codes: **U6A-B** (20 m)

**U6A-B-100** (100 m)

● Conductive urethane tube holder

**DTRY-NZR31**

Note: For use with conductive urethane tube only.



\* Two fixing screws included

● AC adapter

**DTY-ZKPS**



Rating  
 Input: 100 to 240VAC  
 Input: 50/60 Hz 0.58 A  
 Output: 24VDC 1 A

● Discharge needle replacement unit

**DTY-ZKEM**



(Color: white)

### Controller (only for DTY-ELK01 series)

● Controller (main unit only)

**DTY-ZKCR**

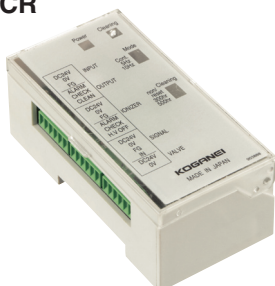

● Controller unit (with solenoid valve)

**DTY-ZKCRU**

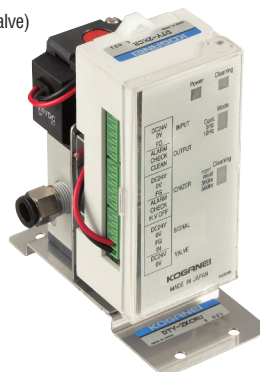

# Order Codes

## Blow type DTY-ELK01-S (Low air consumption type)

### Main Unit

- 1-Head Type  
DTY-ELK01-S



**Caution** A low air consumption type comes with a low air consumption type standard nozzle installed on the main unit.

### Low Air Consumption Type Nozzles

- Standard nozzle (for replacement)  
DTY-NZK-01SS



\* Fixing pin included

**Caution** A low air consumption type comes with a low air consumption type standard nozzle installed on the main unit.

- Tube nozzle (500 mm silicon tube, with tube holder)  
DTY-NZK-03SS



Screws onto standard nozzle.



\* Two fixing screws included



### Low Air Consumption Type Options (sold separately)

- Silicon tube (500 mm for low air consumption type tube nozzle)  
DTY-ZKTS

Outer diameter:  $\phi 12$   
Inner diameter:  $\phi 8$

Note 1: Tubes are consumables and require periodic replacement.  
2: For use with ionizers only. Do not use for pneumatic equipment piping.

- Tube holder (holder for low air consumption type tube nozzle)  
DTY-ZKTHS



\* Two fixing screws included

- Filters (5-filter set for low air consumption type)  
DTY-ZKFS

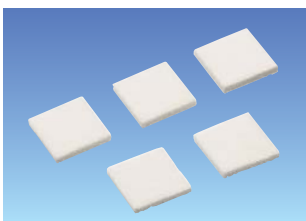

- AC adapter  
DTY-ZKPS



Rating  
Input: 100 to 200VAC  
Input: 50/60 Hz 0.58 A  
Output: 24VDC 1 A

- Discharge needle replacement unit (for low air consumption type)  
DTY-ZKEMS

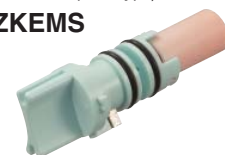

(Color: Light blue)

### Controller (only for DTY-ELK01 series)

- Controller (main unit only)  
DTY-ZKCR



- Controller unit (with solenoid valve)  
DTY-ZKCRU



## Blow Type DTY-ELK01-L (Low Particle Generation Type)

### Main Unit

#### ● 1-Head Type DTY-ELK01-L



**Caution** Main unit cannot be used alone. Always use it in combination with a nozzle.

Reference: Main unit comes in single-layer clean packaging.

### Low Particle Generation Type Nozzles

#### ● Standard nozzle DTY-NZK-01SL



\* Fixing pin included

#### ● Pipe nozzle DTY-NZK-02SL



\* Fixing pin included

#### ● Bender nozzles

**DTY-NZK-100DL** (Nominal dimension: 100 mm)  
**DTY-NZK-200DL** (Nominal dimension: 200 mm)  
**DTY-NZK-300DL** (Nominal dimension: 300 mm)  
**DTY-NZK-400DL** (Nominal dimension: 400 mm)  
**DTY-NZK-500DL** (Nominal dimension: 500 mm)



\* Fixing pin included

#### ● Straight bar nozzles

**DTY-NZK-100BL** (Nominal dimension: 100 mm)  
**DTY-NZK-200BL** (Nominal dimension: 200 mm)  
**DTY-NZK-300BL** (Nominal dimension: 300 mm)  
**DTY-NZK-400BL** (Nominal dimension: 400 mm)  
**DTY-NZK-500BL** (Nominal dimension: 500 mm)



\* Fixing pin included

Reference: Nozzle for low particle generation type comes in single-layer clean package.

### Low Particle Generation Type Options (sold separately)

#### ● Fluororesin tube (500 mm soft type for low particle generation type)

##### DTY-ZKTL

Outer diameter:  $\phi 6$   
 Inner diameter:  $\phi 4$   
 Color: Transparent

Note 1: Tubes are consumables and require periodic replacement.  
 2: For use with ionizers only. Do not use for pneumatic equipment piping.  
 3: Flush before use.

Remarks: For information about tube minimum bending radius, see page

⑦. Fluororesin tube comes in single-layer clean packaging.

#### ● Discharge needle replacement unit (for low particle type)

##### DTY-ZKEML

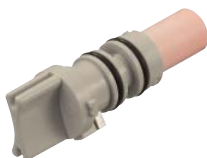

(Color: Gray)

Reference: The replacement discharge needle unit comes in single-layer clean packaging.

#### ● AC adapter

##### DTY-ZKPS

Rating  
 Input: 100 to 200VAC  
 Input: 50/60 Hz 0.58 A  
 Output: 24VDC 1 A



#### ● Filter (with check valve)

##### DTY-ZKF40C

Port size R (Rc) 1/8



##### DTY-ZKF80C

Port size R (Rc) 1/4



Notes 1: Check valve generates 50 dust particles or less with a particle diameter of 0.3  $\mu\text{m}$  or greater at 1 cf/min.

2: Do not apply air intermittently (intermittent operation). Doing so can damage the filter membrane.

# Blow Type DTY-ELK01 (Standard Type)

## Dimensions (mm)

### Main Unit

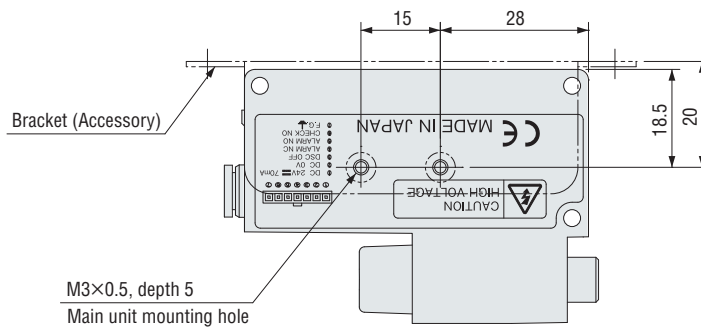
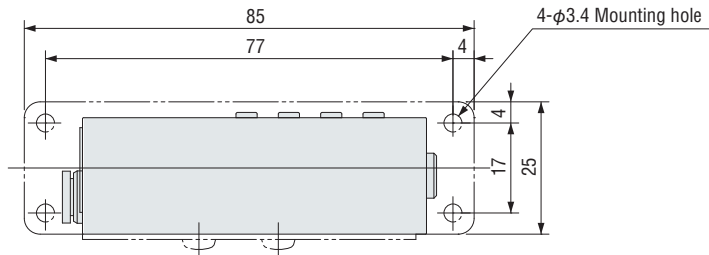
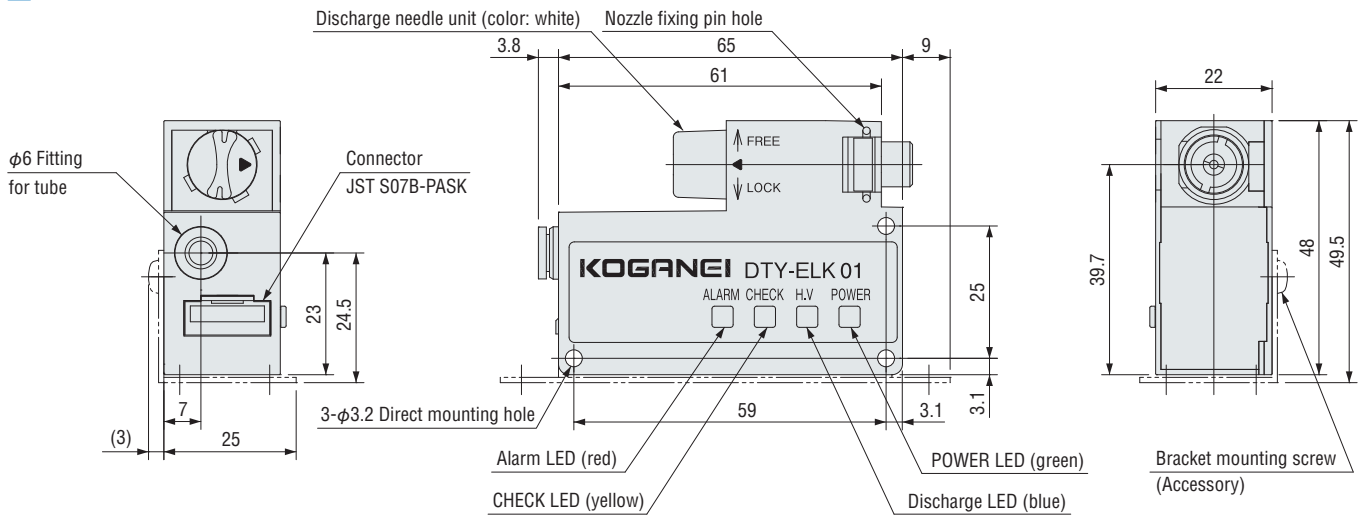

### Circuit Diagram

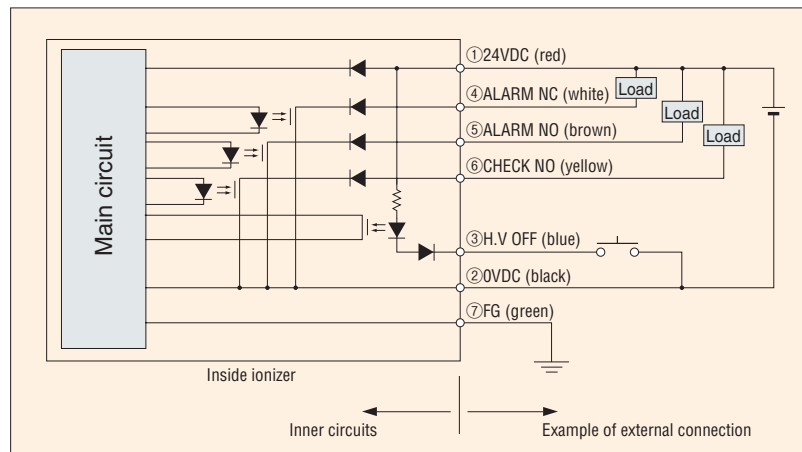



# For Blow Type DTY-ELK01 (Standard Type)

## ■ Nozzles

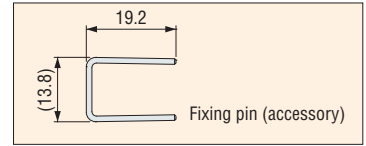

### ● Standard nozzle DTY-NZK-01S

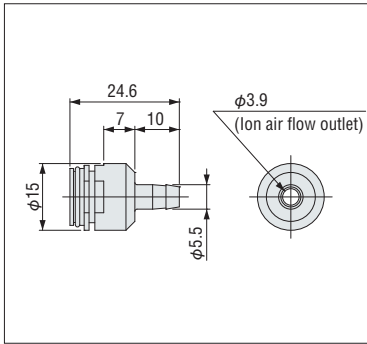

### ● Pipe nozzle DTY-NZK-02S

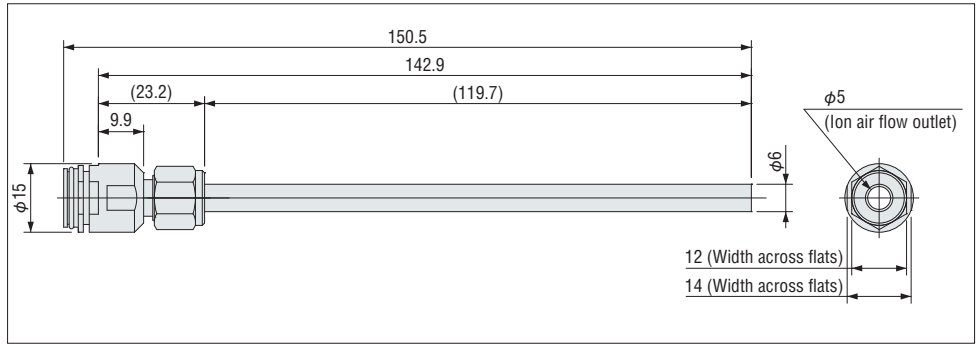

### ● Shower nozzle (60° type) DTY-NZK-60SW

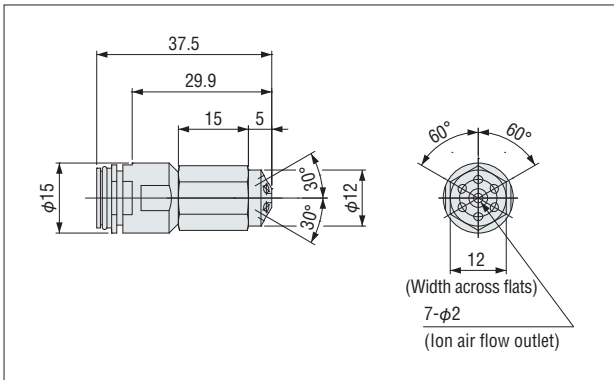

### ● Shower nozzle (90° type) DTY-NZK-90SW

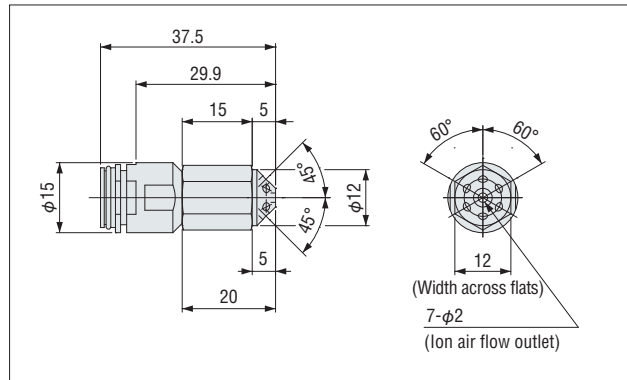

### ● Flat nozzle DTY-NZK-FT

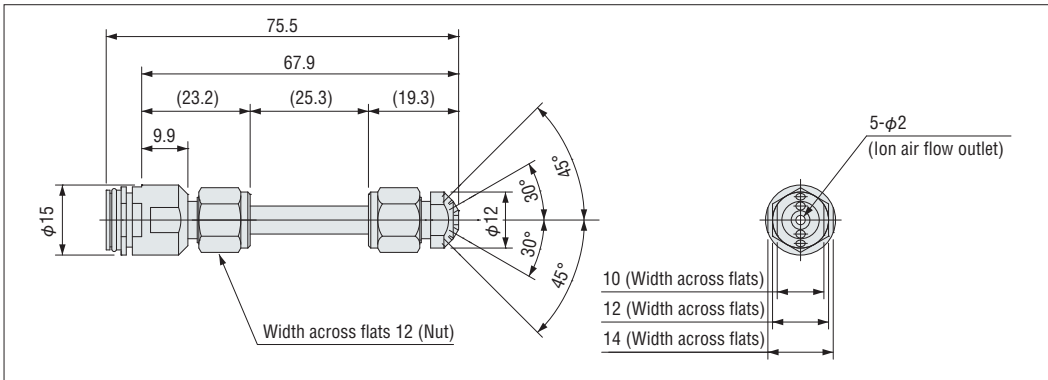

### ● Straight bar nozzle DTY-NZK-□00B

Model	A	B	C	D	L	N
DTY-NZK-100B	10	100	129.7	152.9	160.5	11
DTY-NZK-200B	20	200	229.7	252.9	260.5	21
DTY-NZK-300B	30	300	329.7	352.9	360.5	31
DTY-NZK-400B	40	400	429.7	452.9	460.5	41
DTY-NZK-500B	50	500	529.7	552.9	560.5	51

Remarks 1: Loosen the nut when adjusting the ionized air flow outlet direction. The recommended tightening torque for nuts is 70 to 90 N-cm.  
2: Each nozzle comes with a fixing pin.

# For Blow Type DTY-ELK01 (Standard Type)

## ■ Nozzles

### ● Spiral bar nozzle DTY-NZK-200SP

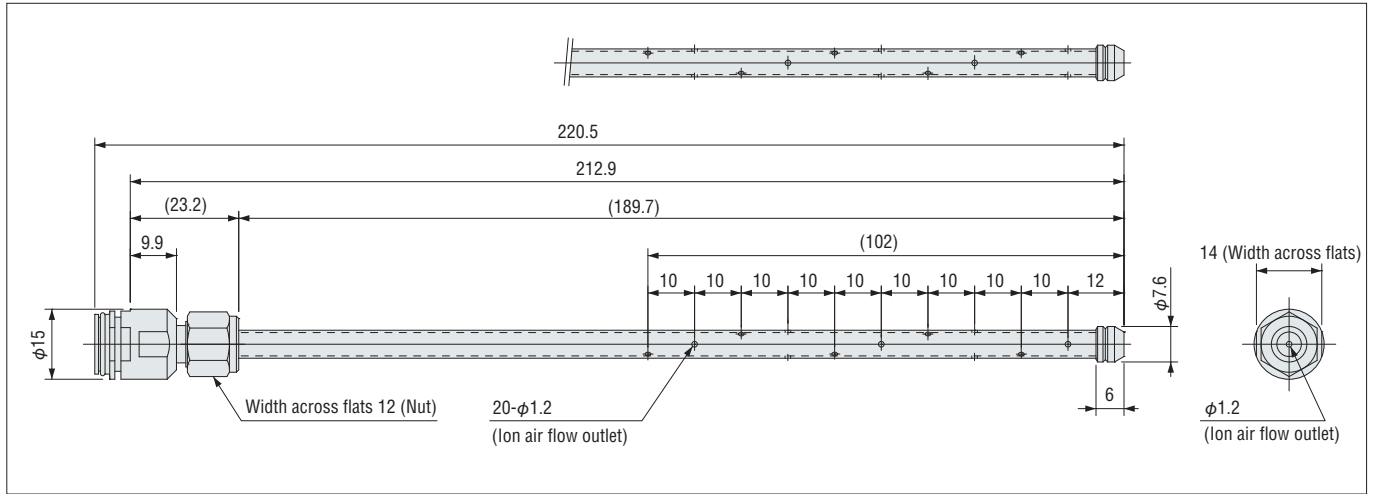

### ● U-shaped bar nozzle DTY-NZK-100U

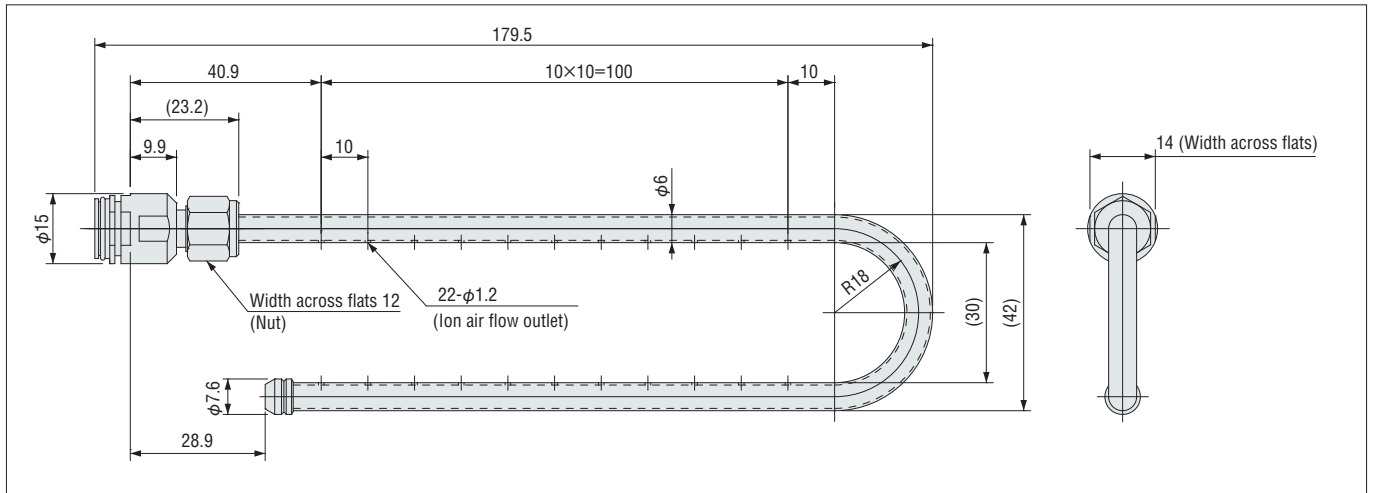

### ● L-shaped bar nozzle DTY-NZK-□00L

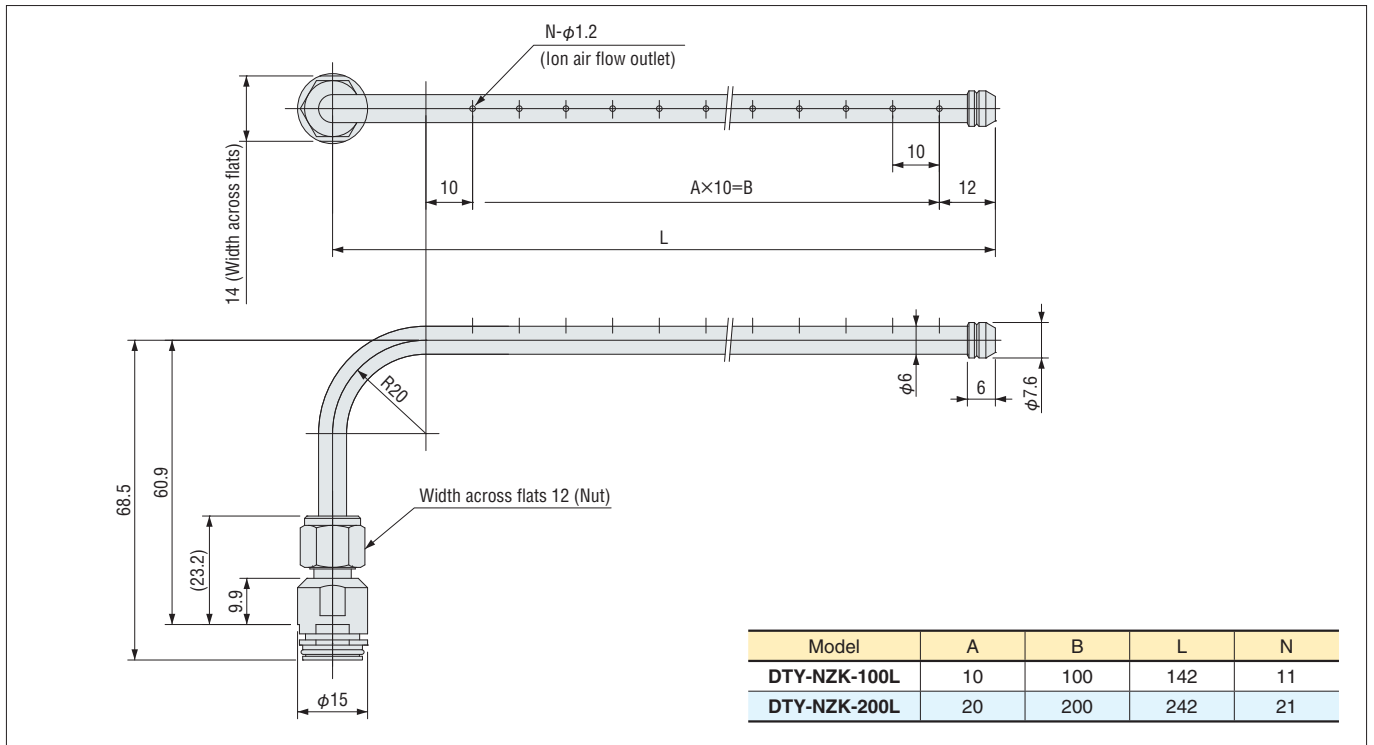

Remarks 1: Loosen the nut when adjusting the ionized air flow outlet direction. The recommended tightening torque for nuts is 70 to 90 N·cm.  
2: Each nozzle comes with a fixing pin.

# For Blow Type DTY-ELK01 (Standard Type)

## ■ Nozzles

### ● Free-mounting L-shaped bar nozzle DTY-NZK-□ 00FMT

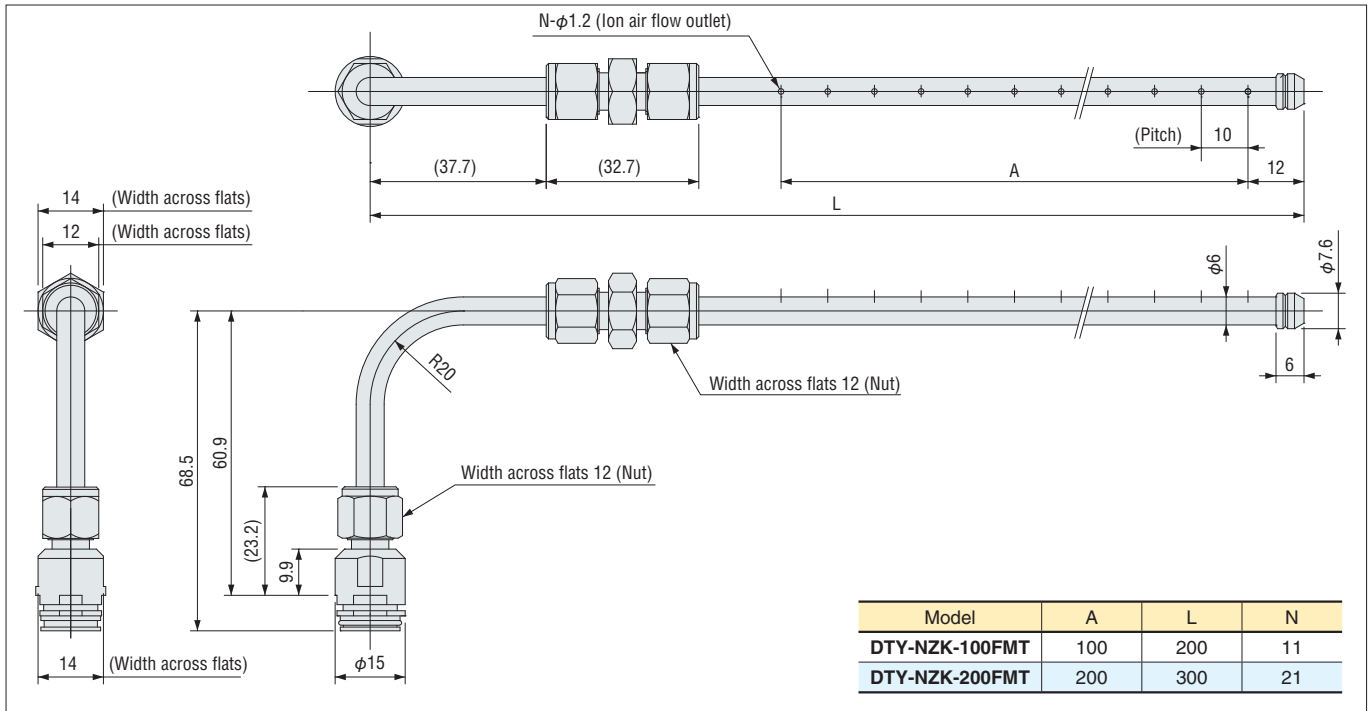

### ● Bender nozzle DTY-NZK-□ 00D

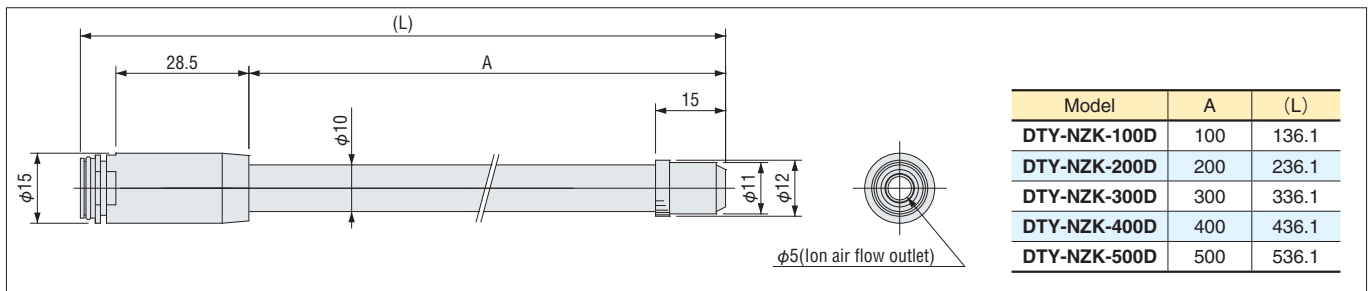

## ■ Tip Options for Bender Nozzles (Select suitable tip to use)

### ● Bender shower nozzle unit (60° type) DTRY-ADN-SW60

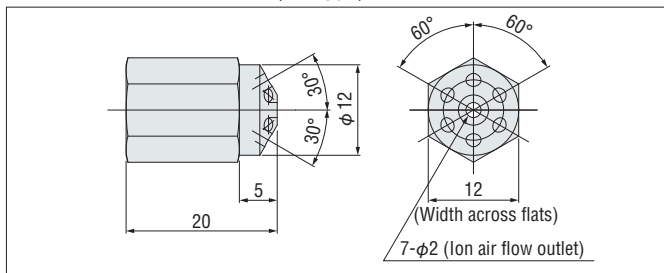

### ● Bender shower nozzle unit (90° type) DTRY-ADN-SW90

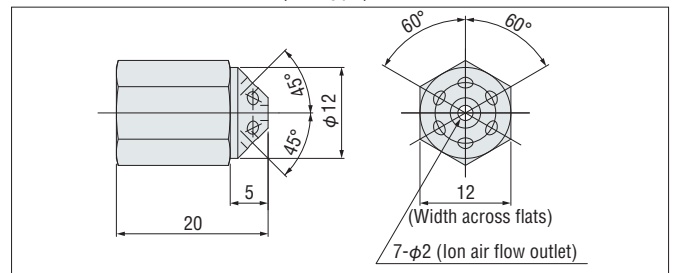

### ● Bender flat nozzle unit DTRY-ADN-FT01

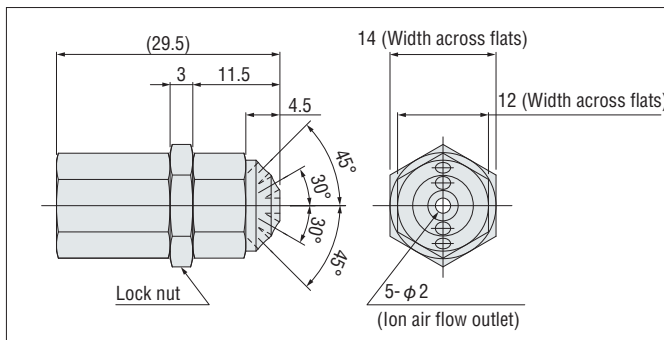

### ● Bender bar nozzle unit DTRY-ADN-□ 00B

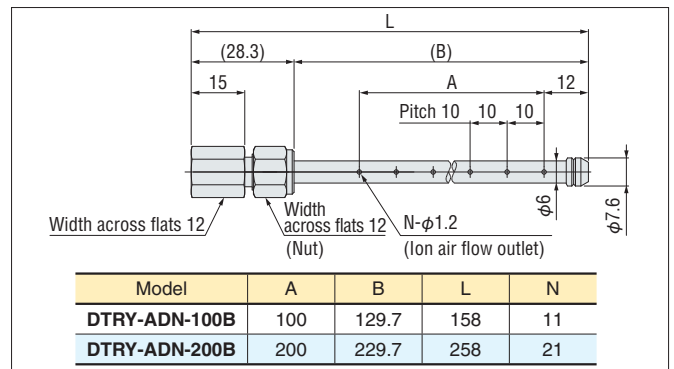

Remarks 1: Loosen the nut when adjusting the ionized air flow outlet direction. The recommended tightening torque for nuts is 70 to 90 N-cm.  
2: Each nozzle comes with a fixing pin.

# For Blow Type DTY-ELK01 (Standard Type)

## Tip Options for Tubes (Connect to the tip to use)

### ● Tube tip shower nozzle unit (60° type) DTY-NZK-H60SW

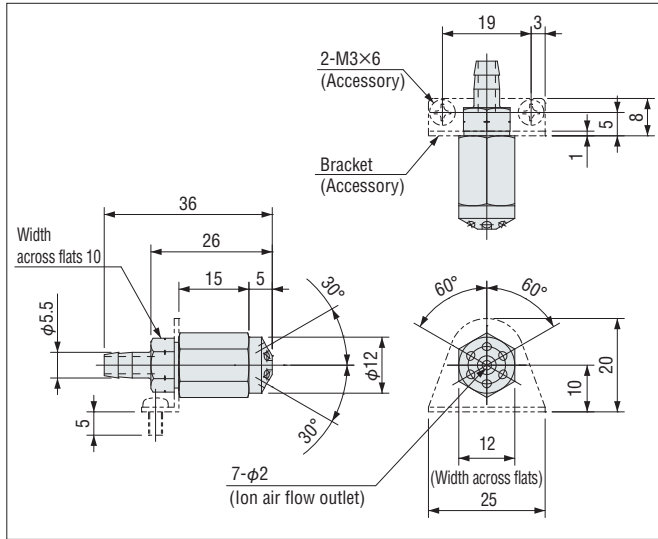

### ● Tube tip shower nozzle unit (90° type) DTY-NZK-H90SW

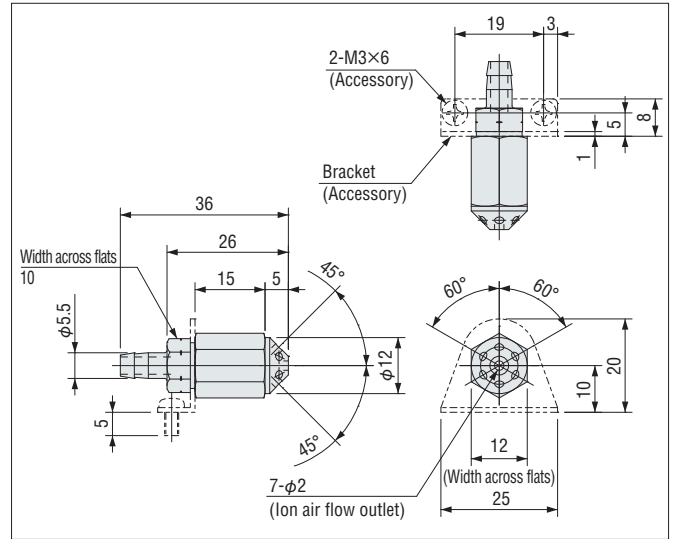

### ● Tube tip flat nozzle unit DTY-NZK-HFT

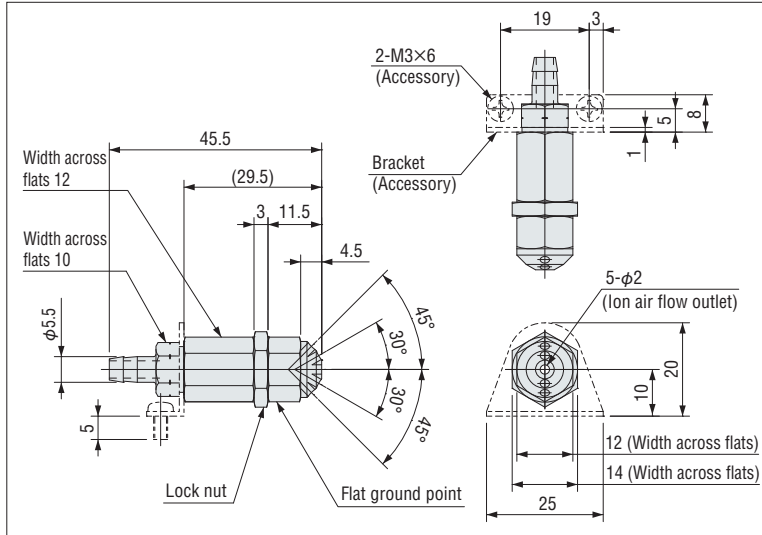

### ● Tube tip bar nozzle unit DTY-NZK-H □ 00B

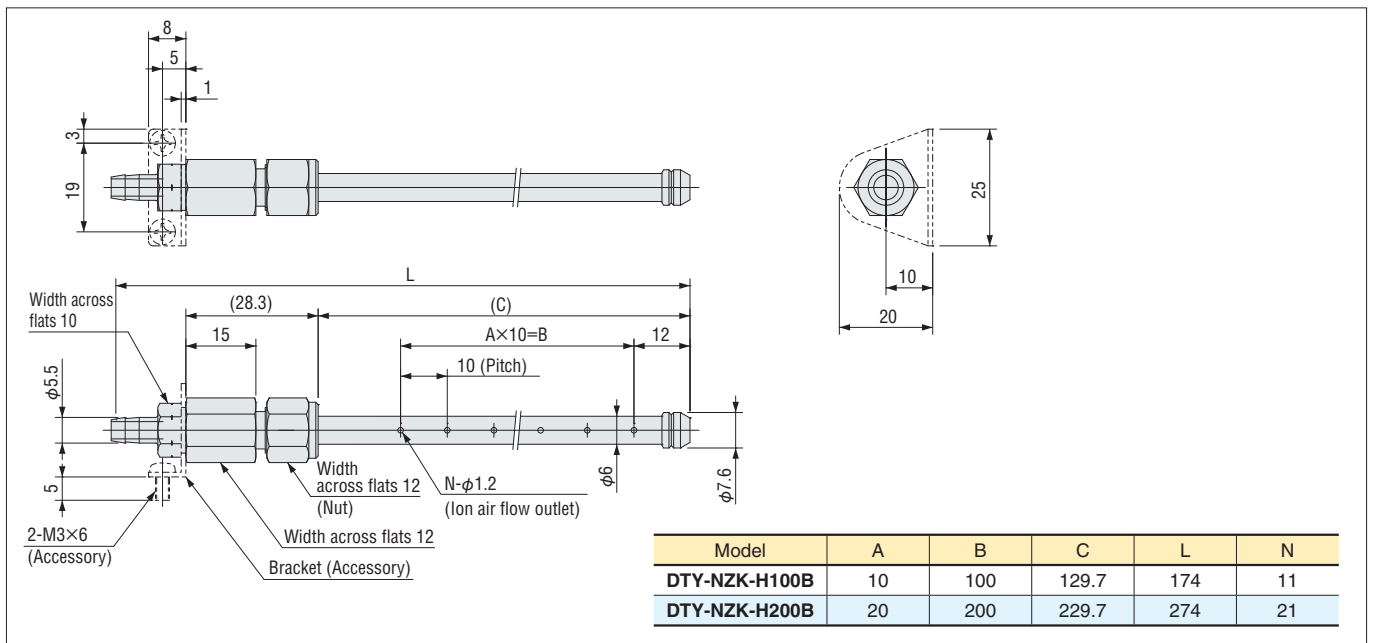

Remarks 1: Loosen the nut when adjusting the ionized air flow outlet direction. The recommended tightening torque for nuts is 70 to 90 N·cm.  
 2: Ground the bracket.  
 3: The bracket can also be used if its orientation is changed.

## For Blow Type DTY-ELK01 (Standard Type)

### ■ Tube

#### ● Conductive urethane tube DTRY-ADN-U

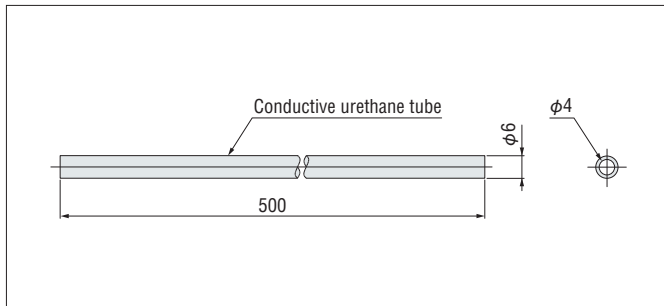

#### ● Teflon tube DTRY-ADN-F

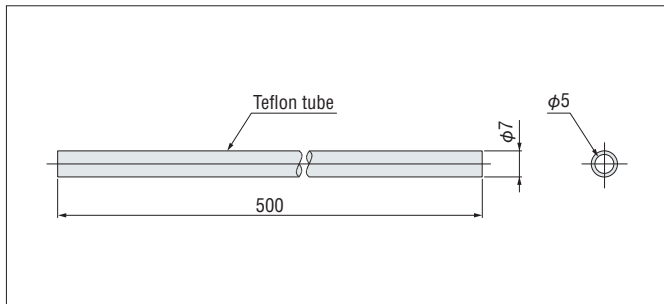

#### ● Silicon tube DTRY-ADN-S

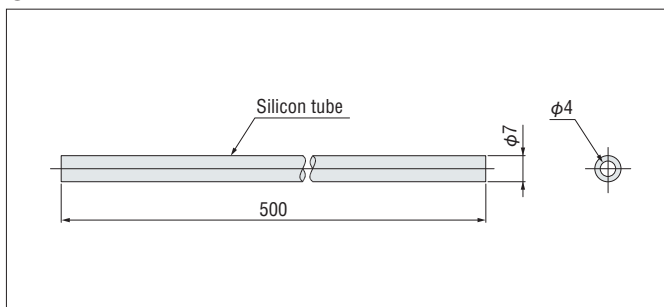

### ■ Conductive urethane tube holder DTRY-NZR31

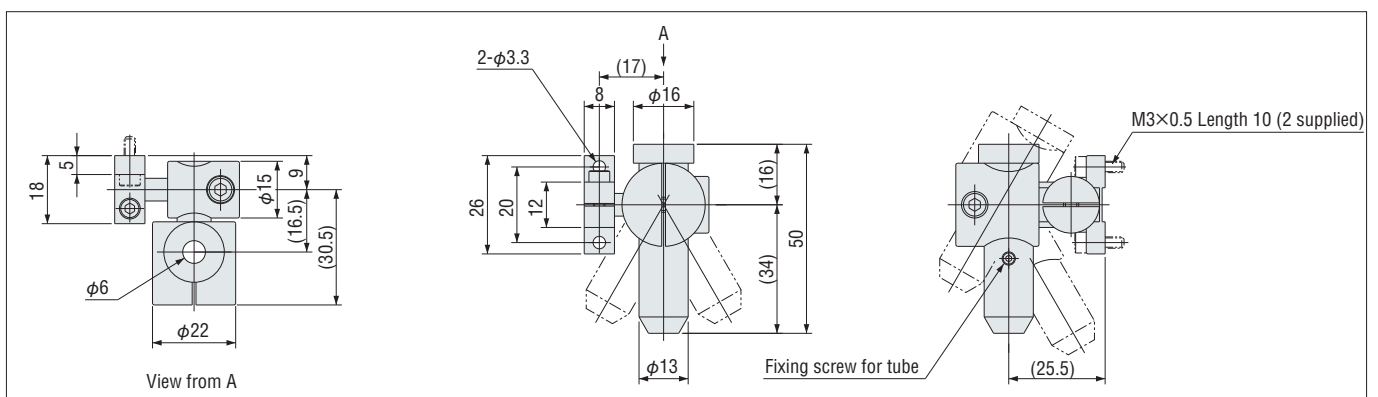

Note: For use with **DTRY-ADN-U** conductive urethane tube only. Cannot be used with **DTRY-ADN-F** Teflon tube or **DTRY-ADN-S** silicon tube.

# Blow Type DTY-ELK01-S (Low Air Consumption Type)

## Dimensions (mm)

### Main Unit

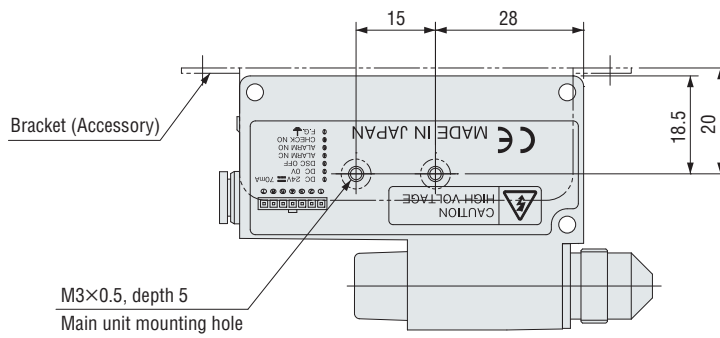
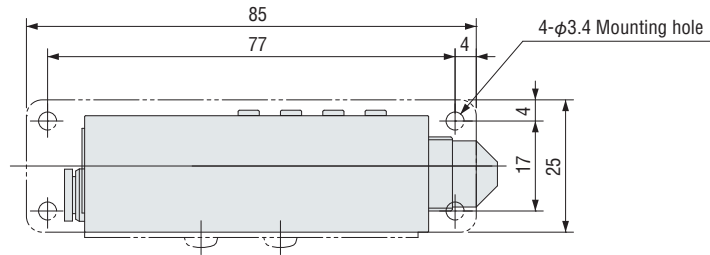
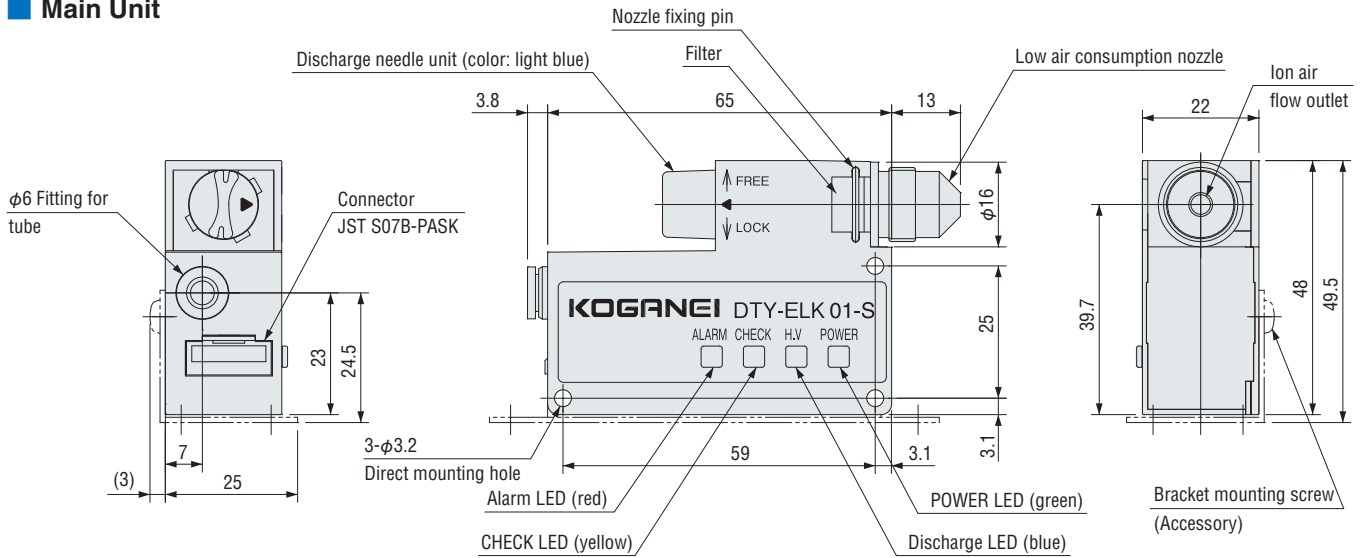

### Circuit Diagram

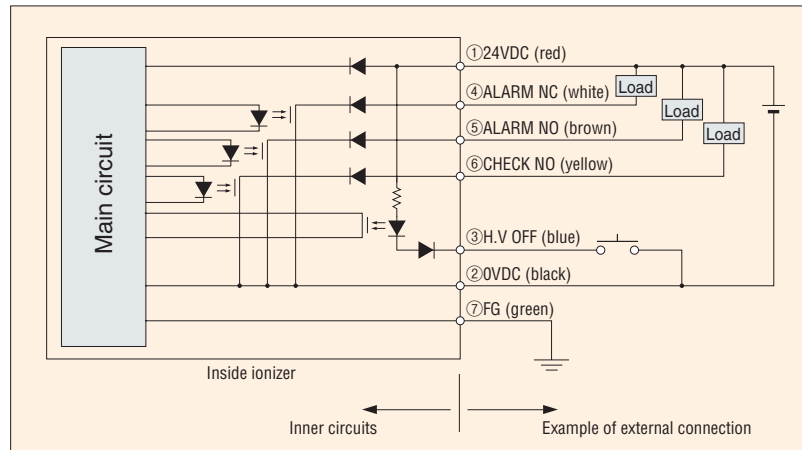

# For Blow Type DTY-ELK01-S (Low Air Consumption Type)

## Nozzles

- Low air consumption type tube nozzle **DTY-NZK-03SS**

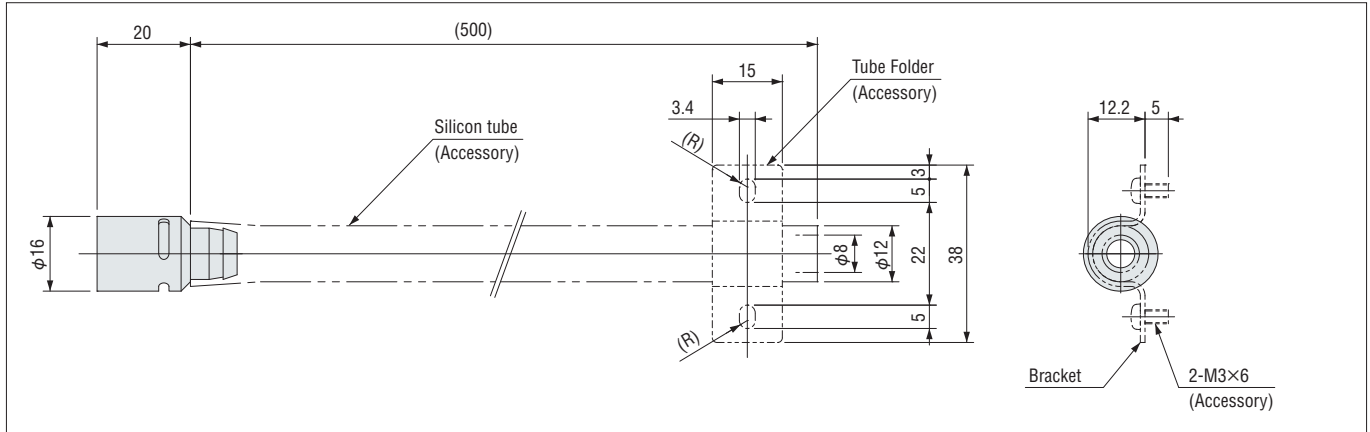

## Options (for replacement)

- Low air consumption type standard nozzle **DTY-NZK-01SS**

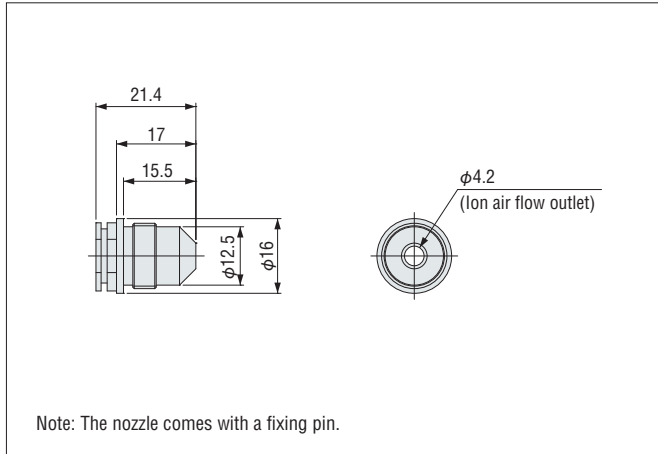

- Tube holder **DTY-ZKTHS**

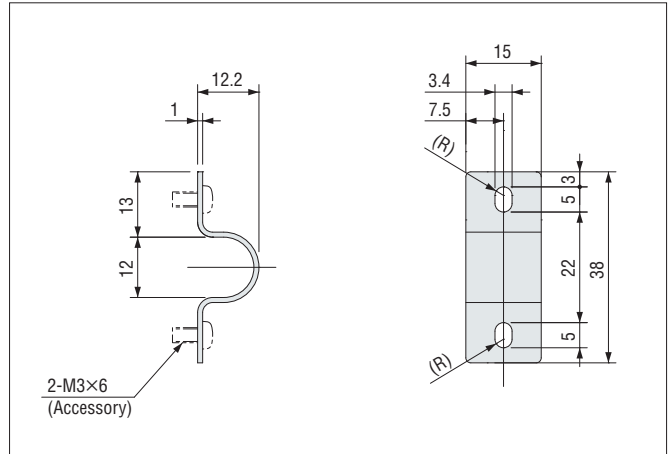

- Silicone tube **DTY-ZKTS**

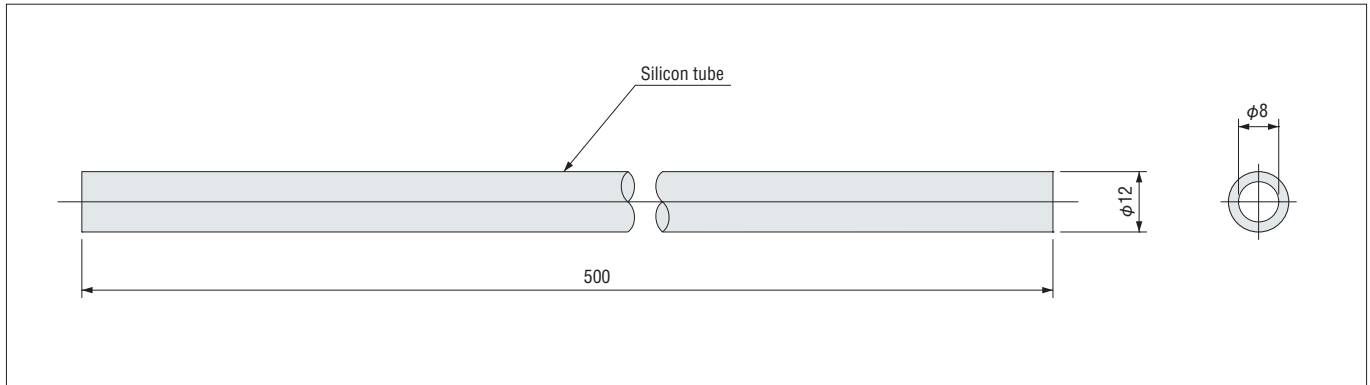

# Blow Type DTY-ELK01-L (Low Particle Generation Type)

## Dimensions (mm)

### Main Unit

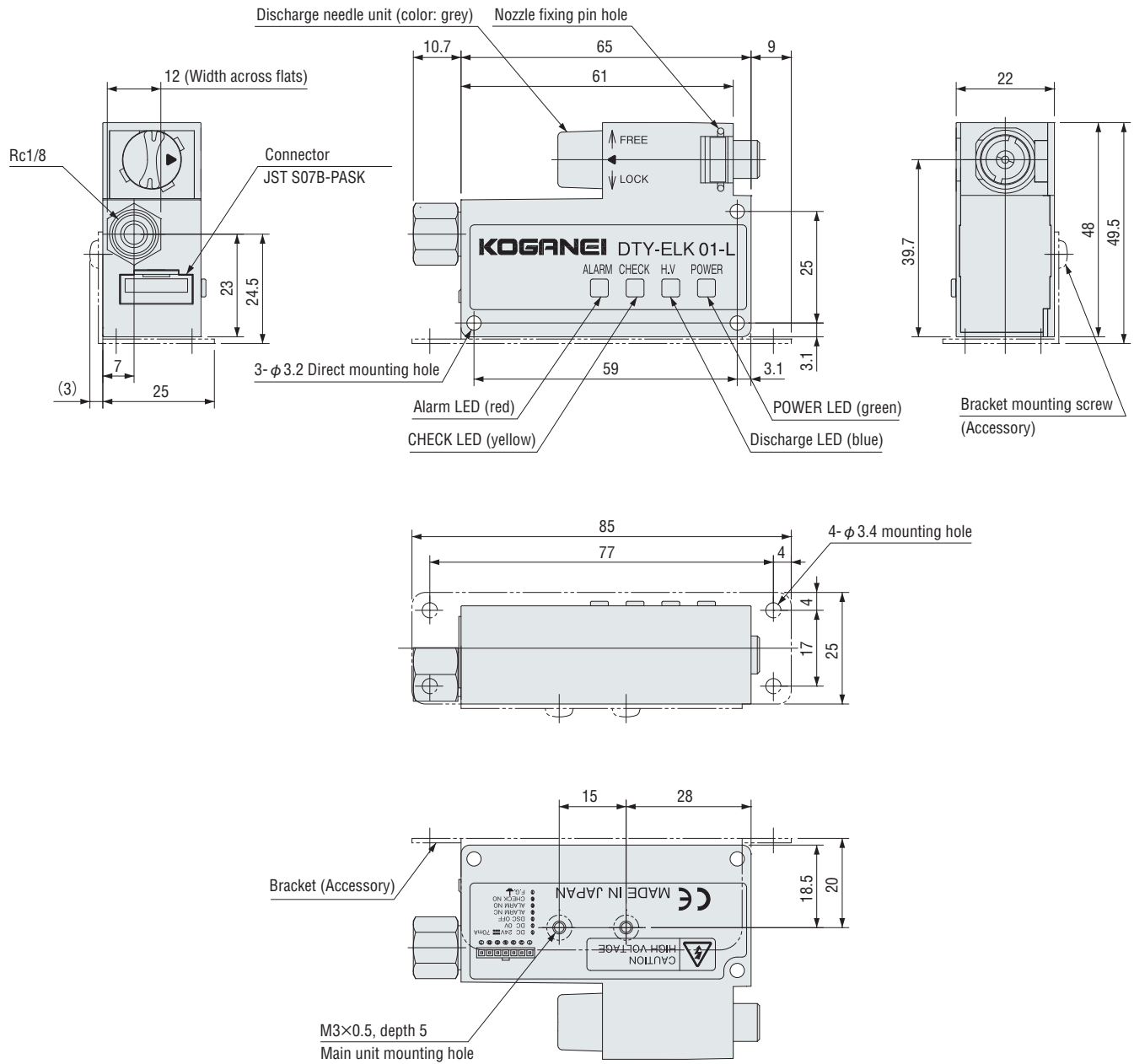

### Circuit Diagram

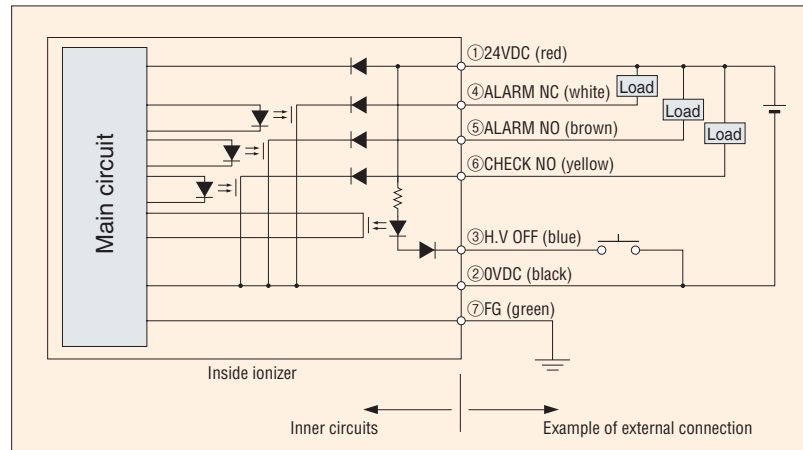



# For Blow Type DTY-ELK01-L (Low Particle Generation Type)

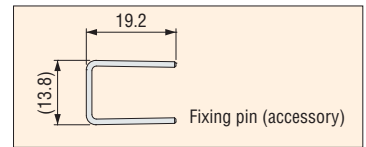

## ■ Nozzles

- Low particle generation type standard nozzle **DTY-NZK-01SL**

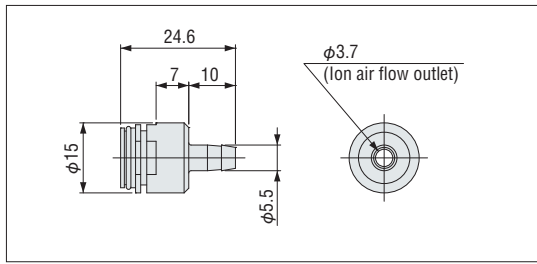

## ■ Tube

- Fluororesin tube **DTY-ZKTL**

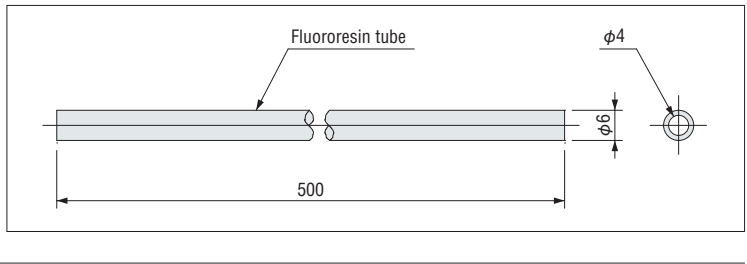

- Low particle generation type pipe nozzle **DTY-NZK-02SL**

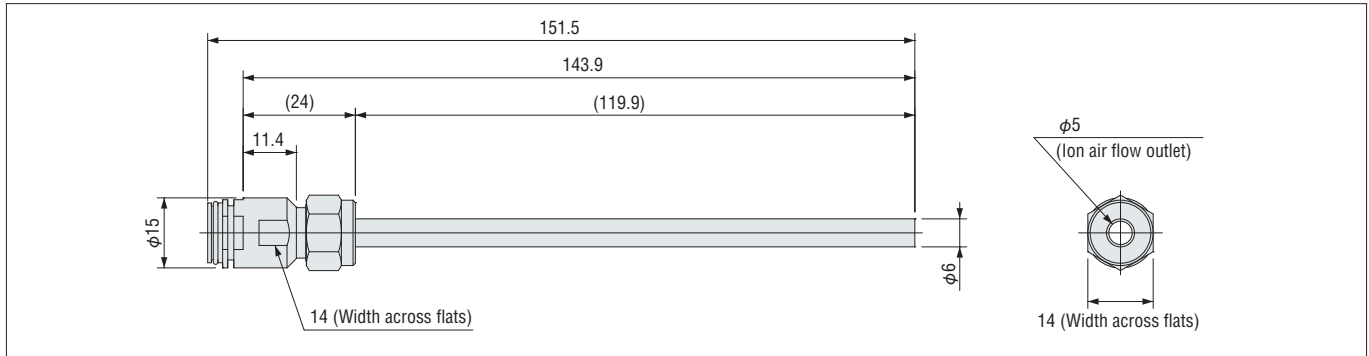

- Low particle generation type bender nozzle **DTY-NZK-□00DL**

Model	A	(L)
DTY-NZK-100DL	100	136.1
DTY-NZK-200DL	200	236.1
DTY-NZK-300DL	300	336.1
DTY-NZK-400DL	400	436.1
DTY-NZK-500DL	500	536.1

- Low particle generation type straight bar nozzle **DTY-NZK-□00BL**

Model	A	B	C	D	L	N
DTY-NZK-100BL	10	100	128.9	152.9	160.5	11
DTY-NZK-200BL	20	200	228.9	252.9	260.5	21
DTY-NZK-300BL	30	300	328.9	352.9	360.5	31
DTY-NZK-400BL	40	400	428.9	452.9	460.5	41
DTY-NZK-500BL	50	500	528.9	552.9	560.5	51

Remarks 1: Loosen the nut when adjusting the ionized air flow outlet direction. The recommended tightening torque for nuts is 70 to 90 N·cm.  
2: Each nozzle comes with a fixing pin.

# Blow Type DTY-ELK01 Series Common Options

## Dimensions (mm)

### ● Controller (main unit only) DTY-ZKCR

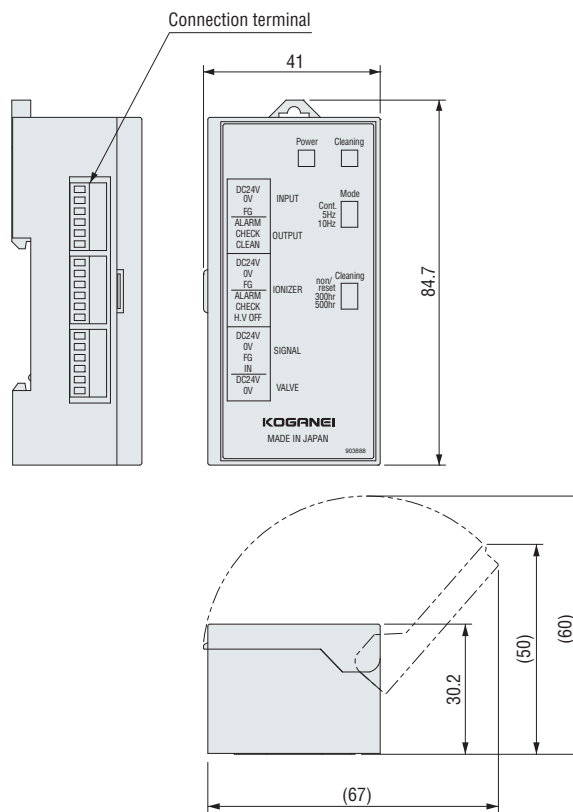

### ● Controller unit (solenoid valve built-in) DTY-ZKCRU

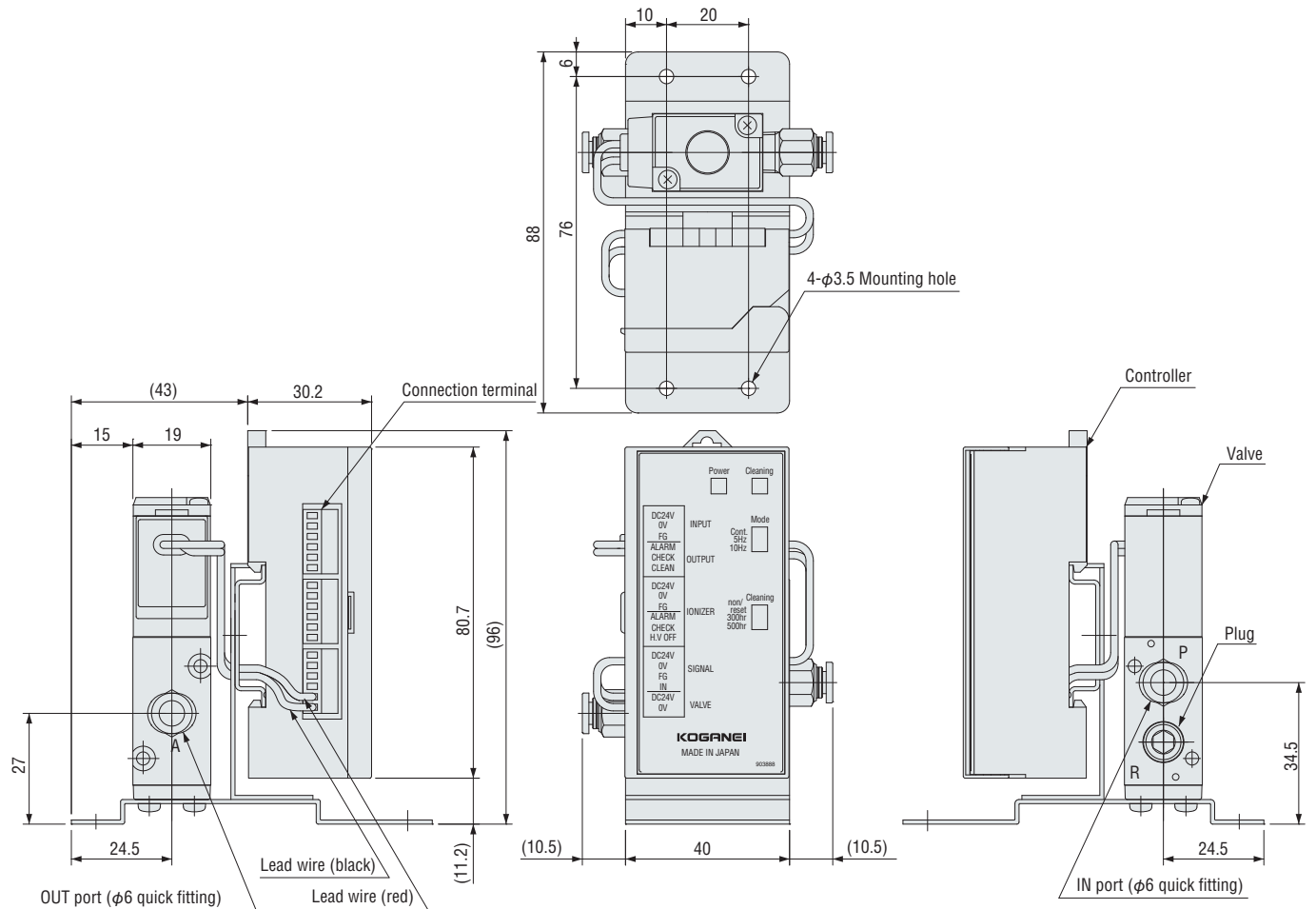

# Static Charge Removal Characteristic Graphs

## Blow Type DTY-ELK01 (Standard Type)

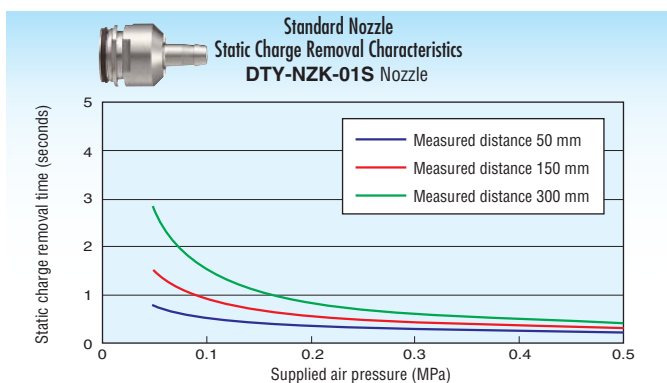
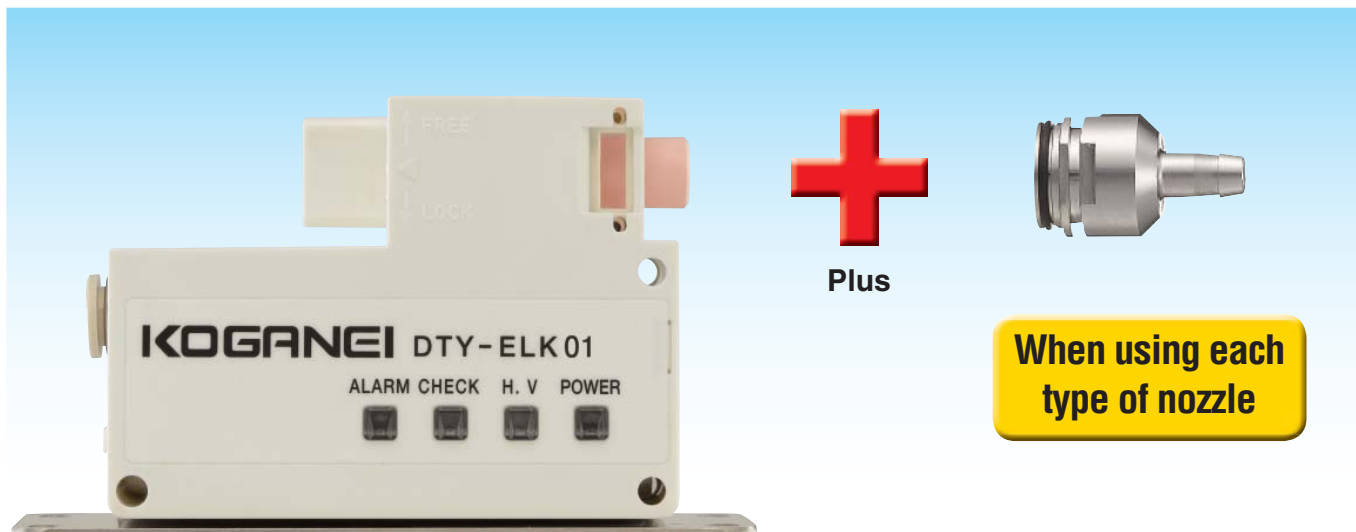

Notes 1: Measurement performed under KOGANEI standards using a 20 pF, □150 mm charged plate monitor.  
 2: Static charge removal time is the decay time from ±1000V to ±100V.  
 3: Static charge removal characteristics are values measured by KOGANEI. These values are not guaranteed.

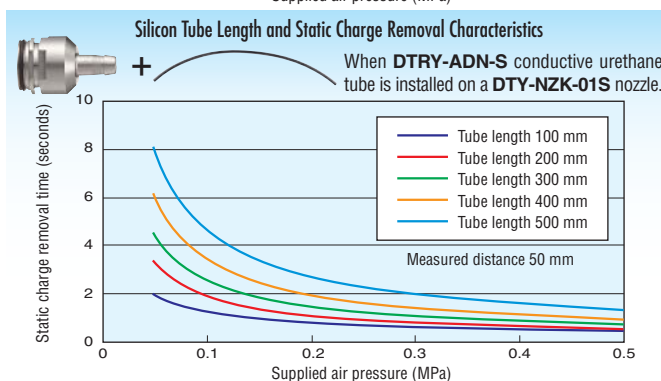
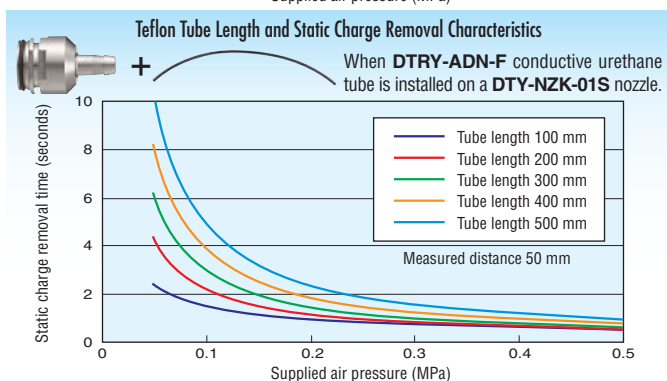
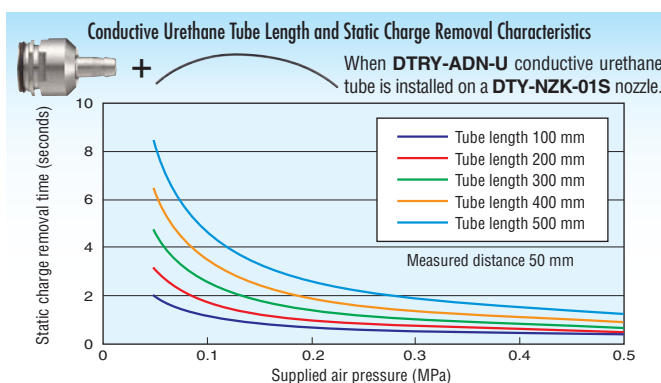
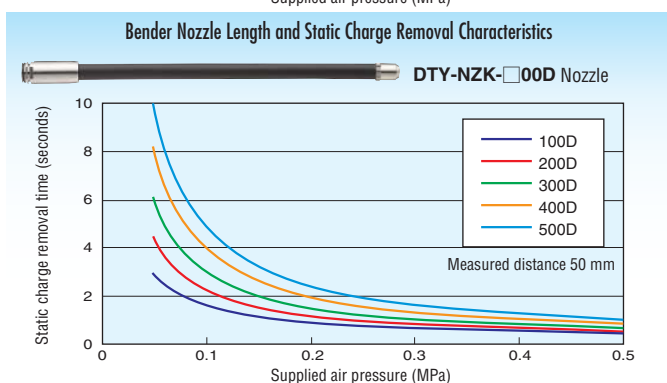

# Static Charge Removal Characteristic Graphs

Pipe Nozzle Static Charge Removal Characteristics

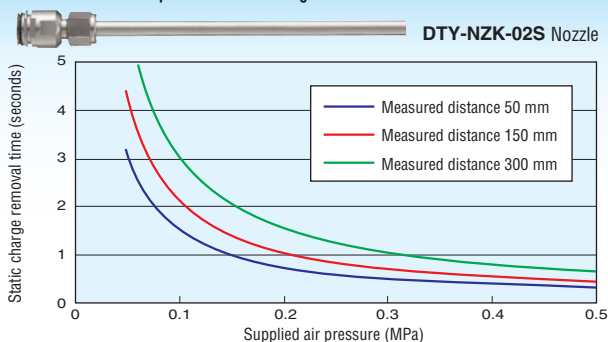

Shower Nozzle (60° Type) Static Charge Removal Characteristics

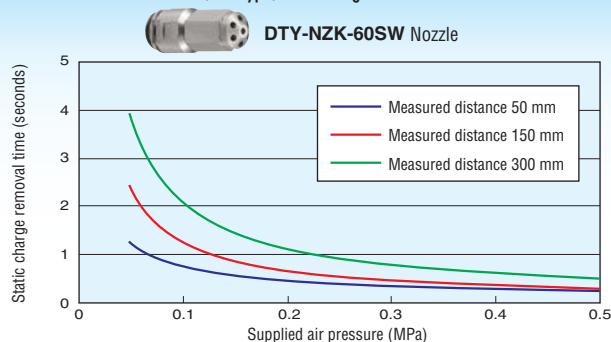

Shower Nozzle (90° Type) Static Charge Removal Characteristics

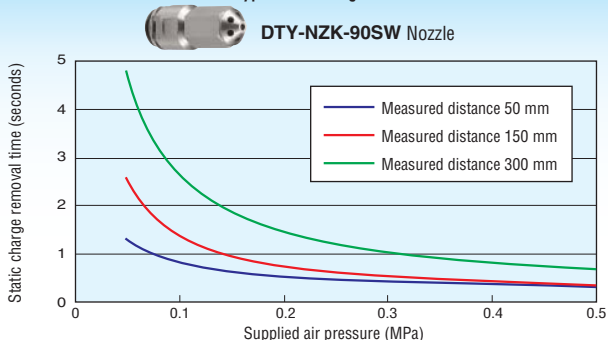

Flat Nozzle Static Charge Removal Characteristics

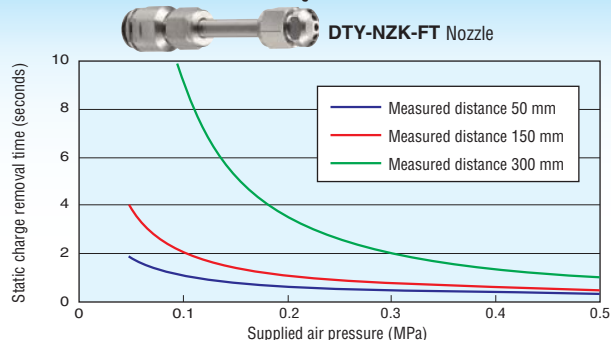

Spiral Bar Nozzle Static Charge Removal Characteristics

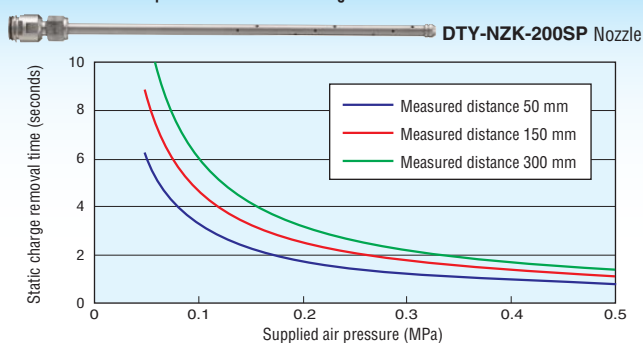

Straight Bar Nozzle (100 mm) Static Charge Removal Characteristics

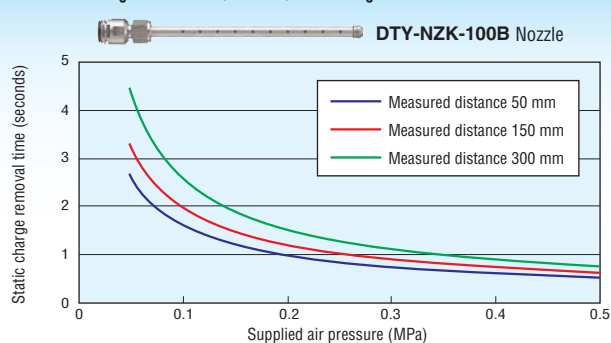

Straight Bar Nozzle (200 mm) Static Charge Removal Characteristics

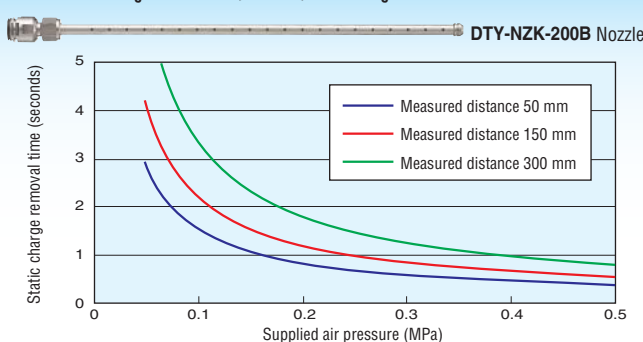

Straight Bar Nozzle (300 mm) Static Charge Removal Characteristics

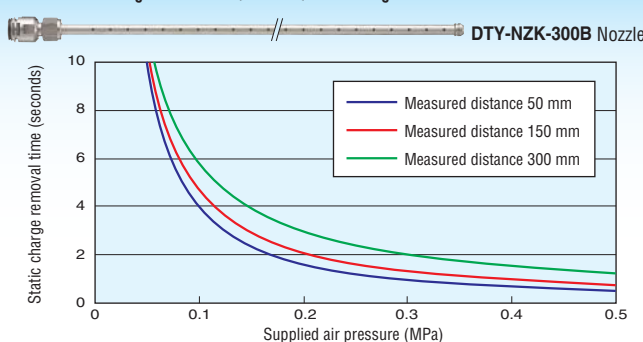

Straight Bar Nozzle (400 mm) Static Charge Removal Characteristics

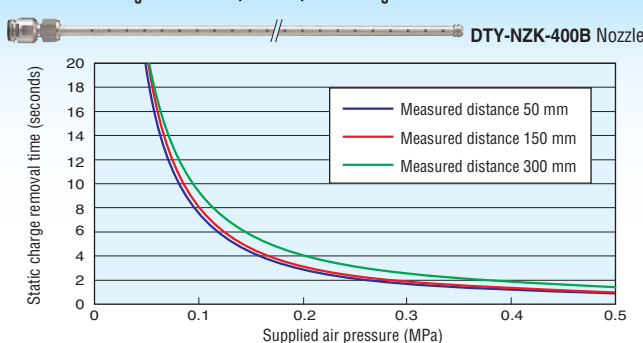

Straight Bar Nozzle (500 mm) Static Charge Removal Characteristics

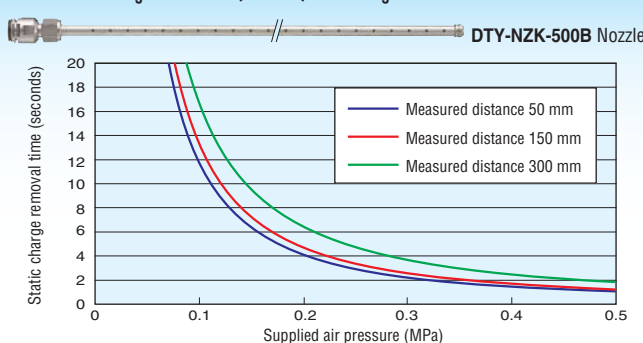

### L-shaped Bar Nozzle (100 mm) Static Charge Removal Characteristics

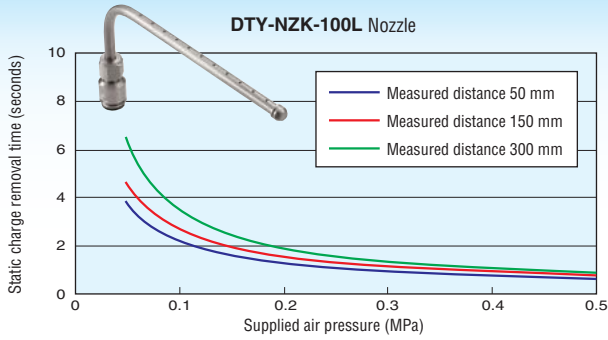

### L-shaped Bar Nozzle (200 mm) Static Charge Removal Characteristics

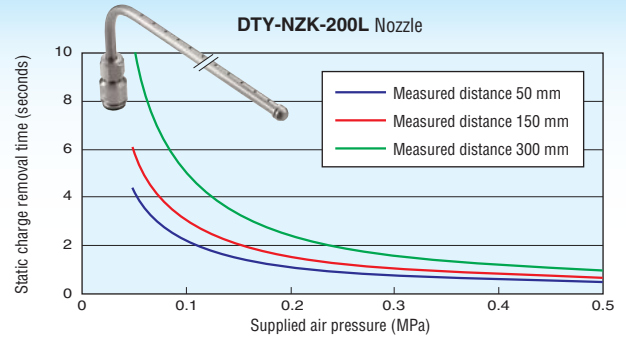

### Free Mounting L-Shaped Bar Nozzle (100 mm) Static Charge Removal Characteristics

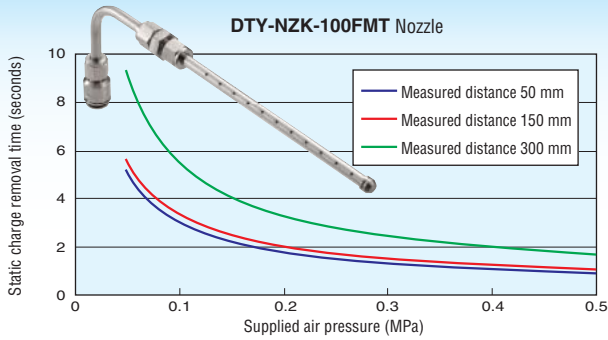

### Free Mounting L-Shaped Bar Nozzle (200 mm) Static Charge Removal Characteristics

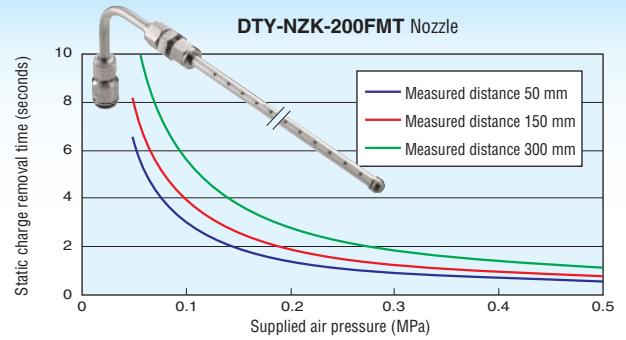

### U-shaped Bar Nozzle Static Charge Removal Characteristics

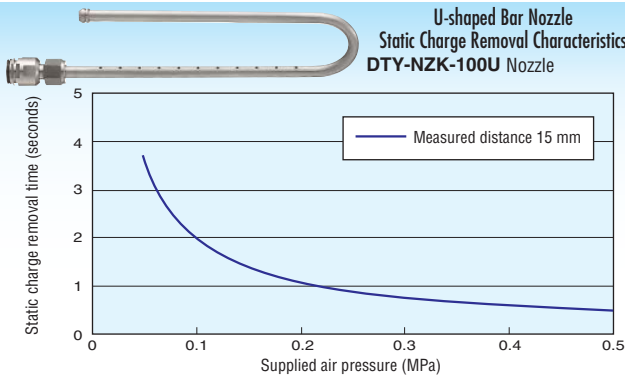

### Bender Nozzle Length and Static Charge Removal Characteristics (Shower Nozzle 60° Type)

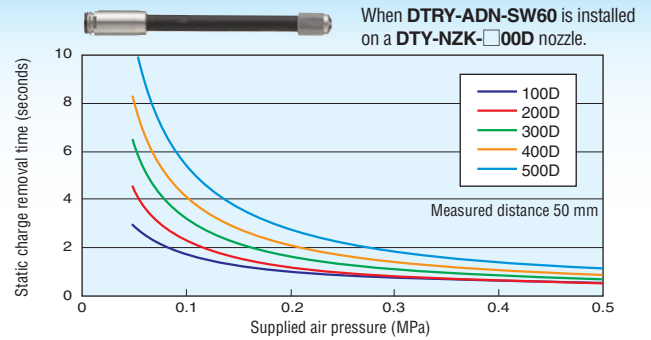

### Bender Nozzle Length and Static Charge Removal Characteristics (Shower Nozzle 90° Type)

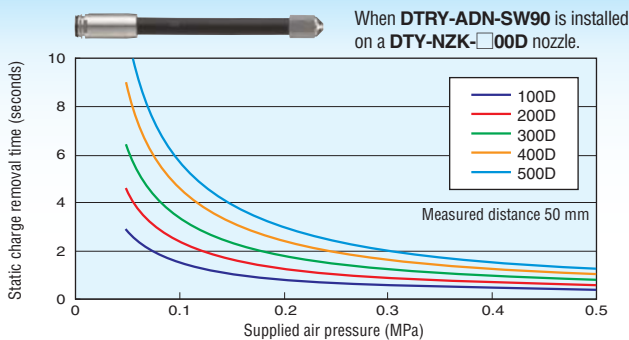

### Bender Bar Nozzle Length and Static Charge Removal Characteristics (Flat Nozzle)

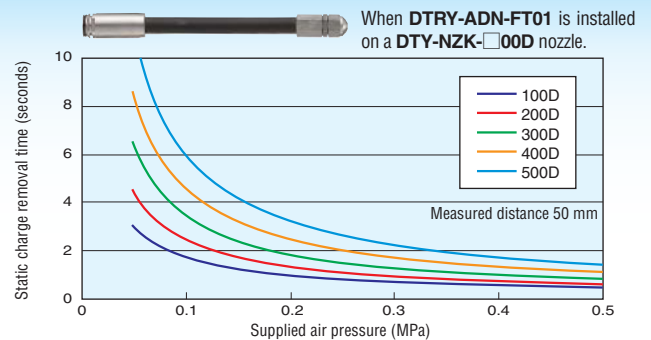

### Bender Nozzle Length and Static Charge Removal Characteristics (Straight Bar Nozzle 100 mm)

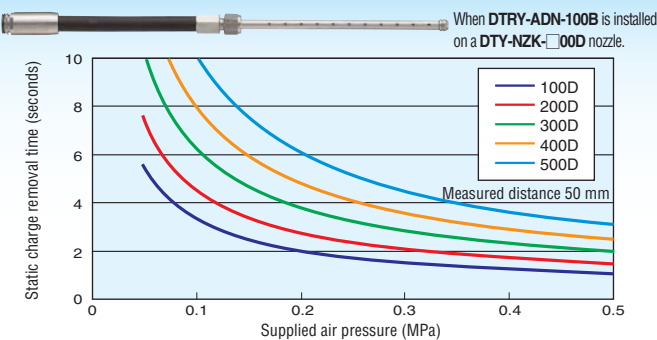

### Bender Nozzle Length and Static Charge Removal Characteristics (Straight Bar Nozzle 200 mm)

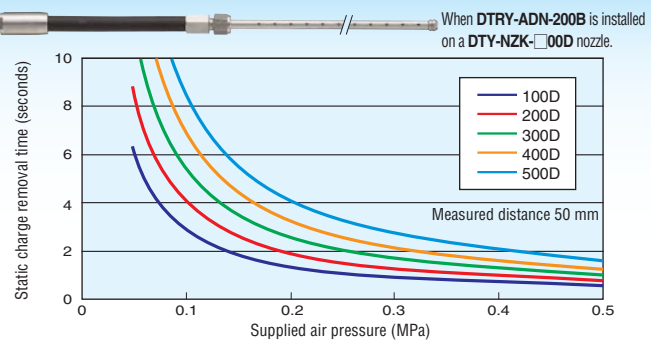

# Static Charge Removal Characteristic Graphs

Tube Length and Static Charge Removal Characteristics (Shower Nozzle 60° Type)



When **DTRY-ADN-S** and **DTY-NZK-H60SW** are installed on the **DTY-NZK-01S** nozzle.

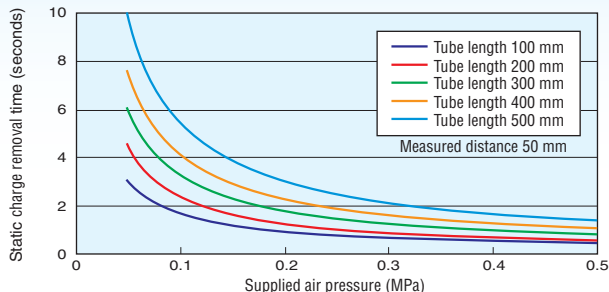

Tube Length and Static Charge Removal Characteristics (Shower Nozzle 90° Type)



When **DTRY-ADN-S** and **DTY-NZK-H90SW** are installed on the **DTY-NZK-01S** nozzle.

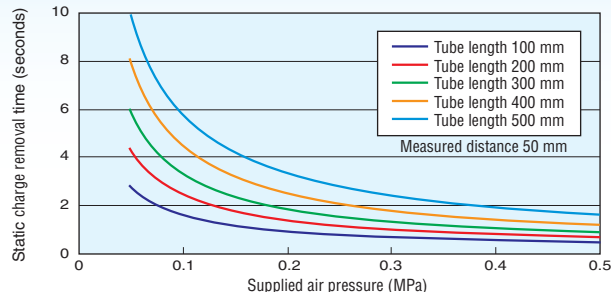

Tube Length and Static Charge Removal Characteristics (Flat Nozzle)



When **DTRY-ADN-S** and **DTY-NZK-HFT** are installed on the **DTY-NZK-01S** nozzle.

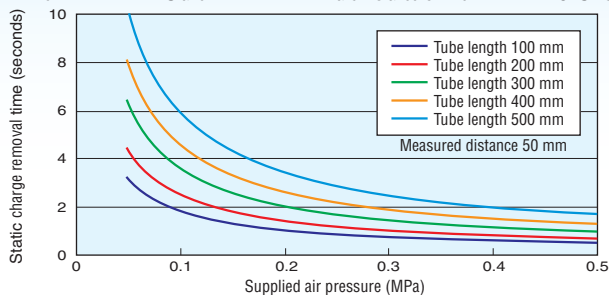

Tube Length and Static Charge Removal Characteristics (Straight Bar Nozzle 100 mm)

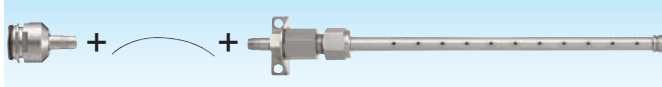

When **DTRY-ADN-S** and **DTY-NZK-H100B** are installed on the **DTY-NZK-01S** nozzle.

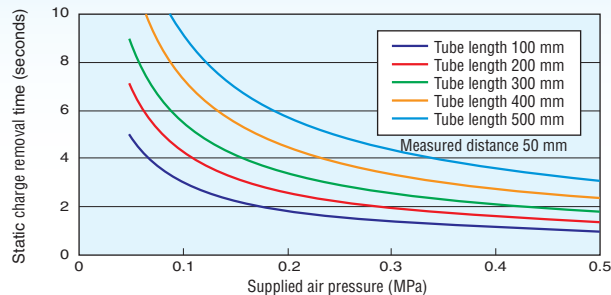

Tube Length and Static Charge Removal Characteristics (Straight Bar Nozzle 200 mm)

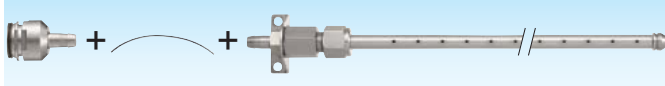

When **DTRY-ADN-S** and **DTY-NZK-H200B** are installed on the **DTY-NZK-01S** nozzle.

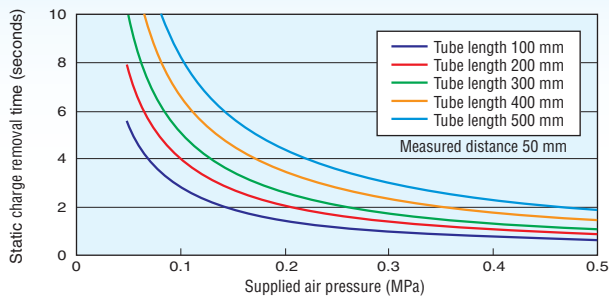

# Static Charge Removal Characteristic Graphs

## Blow Type DTY-ELK01-S (Low Air Consumption Type)



- Notes 1: Measurement performed under KOGANEI standards using a 20 pF, 150 mm charged plate monitor.  
 2: Static charge removal time is the decay time from  $\pm 1000V$  to  $\pm 100V$ .  
 3: Static charge removal characteristics are values measured by KOGANEI. These values are not guaranteed.

Standard Nozzle Static Charge Removal Characteristics



DTY-NZK-01SS Nozzle

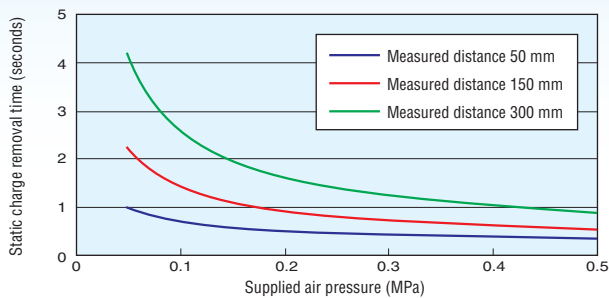

Tube Length and Static Charge Removal Characteristics



When DTY-NZK-03SS is installed on the DTY-NZK-01SS nozzle.

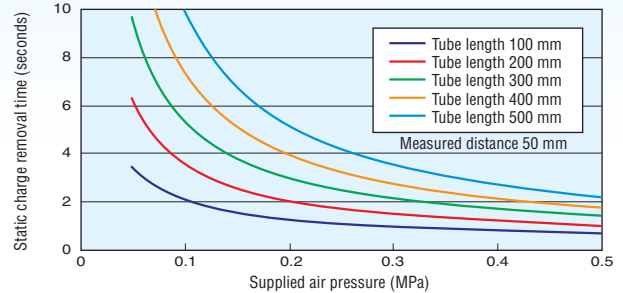

# Static Charge Removal Characteristic Graphs

## Blow Type DTY-ELK01-L (Low Particle Generation Type)

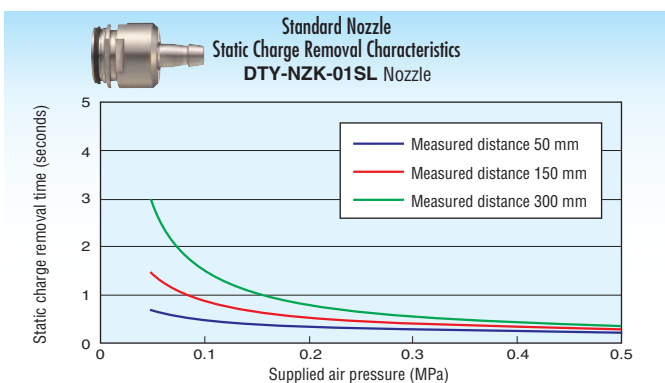
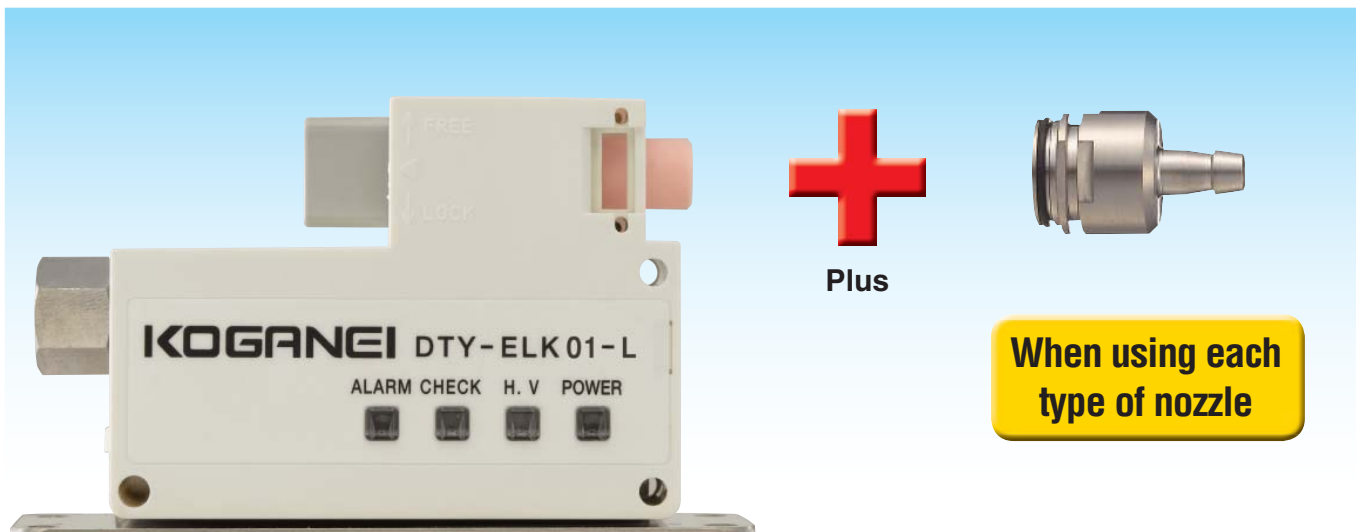

- Notes 1: Measurement performed under KOGANEI standards using a 20 pF, □150 mm charged plate monitor.  
 2: Static charge removal time is the decay time from  $\pm 1000V$  to  $\pm 100V$ .  
 3: Static charge removal characteristics when filter is not installed.  
 4: Static charge removal characteristics are values measured by KOGANEI. These values are not guaranteed.

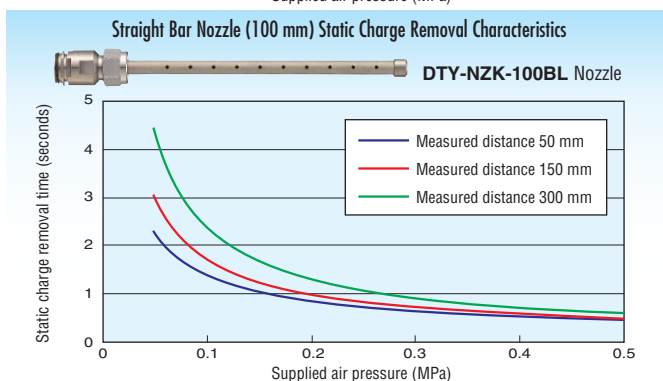
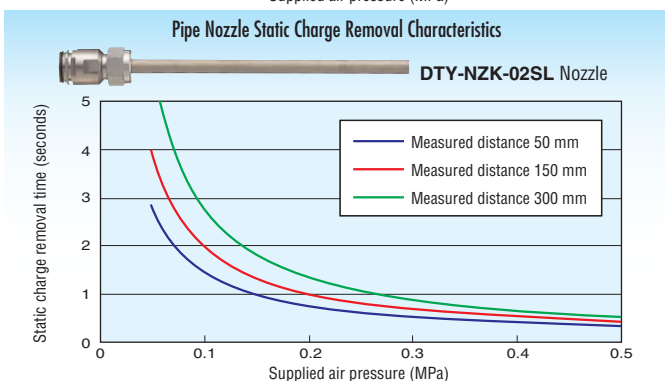
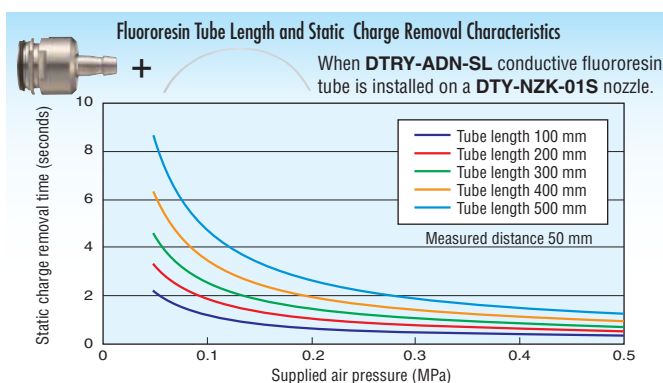
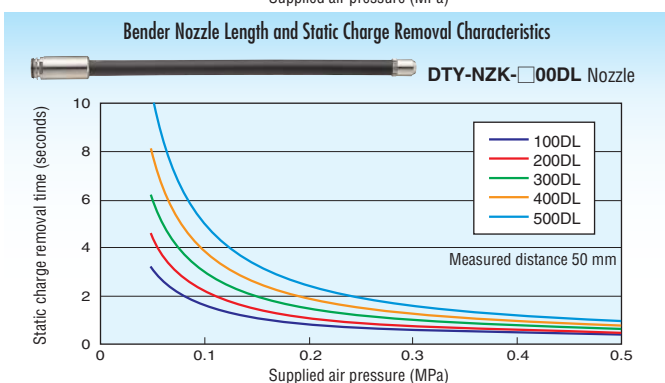



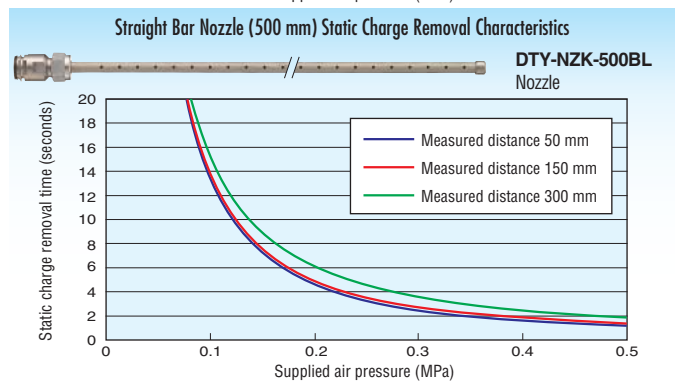
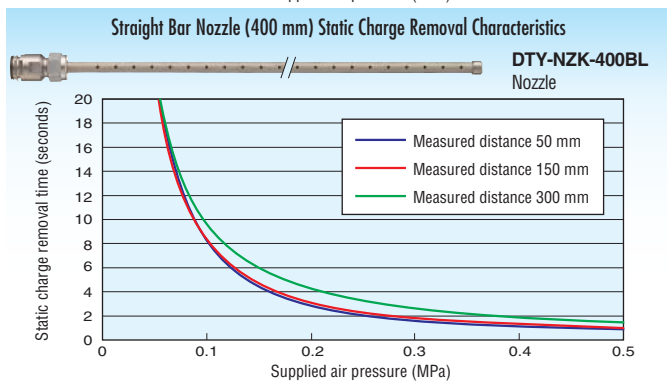
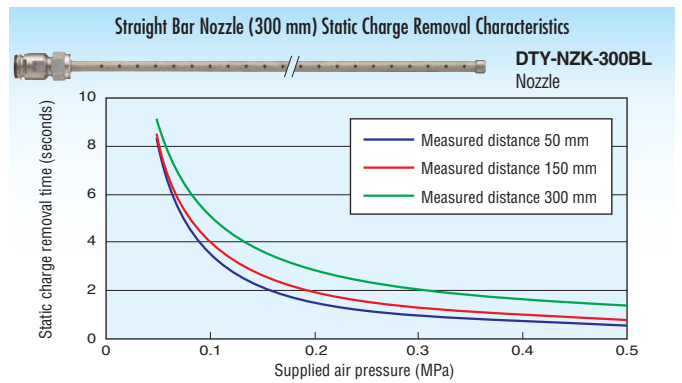
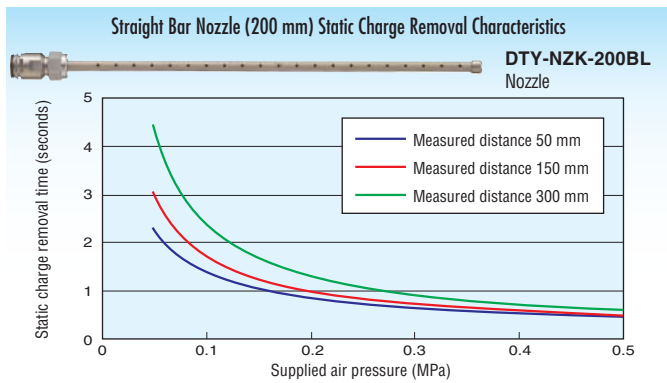

## Flow Rate Characteristics Graph

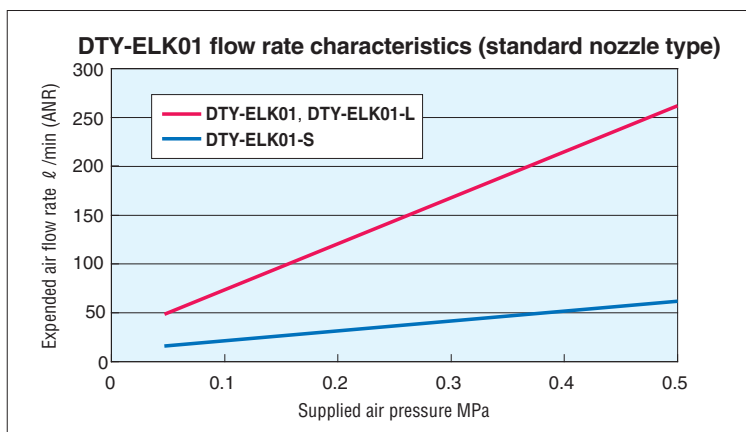

# Filter

## Specifications

Item	Model	DTY-ZKF40C	DTY-ZKF80C
Medium		Air	
Port size		R(Rc) 1/8	R(Rc) 1/4
Filtered particle size <sup>Note 1</sup>	μm	0.1	
Particle filtering efficiency <sup>Note 1</sup>	%	99.9	
Processed air volume <sup>Note 1 Note 2</sup> ℓ /min [(ft <sup>3</sup> /min)] (ANR)		40 [1.4]	80 [2.8]
Membrane surface area <sup>Note 1</sup>	cm <sup>2</sup> [in <sup>2</sup> ]	29.9 [4.63]	68.7 [10.65]
Operating pressure range <sup>Note 3</sup>	MPa [psi.]	0.05~0.9 [7~131]	
Guaranteed differential pressure <sup>Note 1</sup>	MPa [psi.]	0.5 [73]	
Operating temperature range	°C [°F]	5~45 [41~113]	
Mass	g [oz.]	33 [1.16]	55 [1.94]
Recommended tightening torque	N·cm [in. lbf]	400~600 [35.4~53.1]	700~900 [62.0~79.7]

Note 1: Specifications for a single filter.

Note 2: When air pressure is 0.7 MPa [102 psi.] (0.03 MPa [4.4 psi.] pressure drop).

Certain operating conditions can cause a reduction of up to 5%.

Note 3: Use within the ionizer operating pressure range.

## Flow rate characteristics

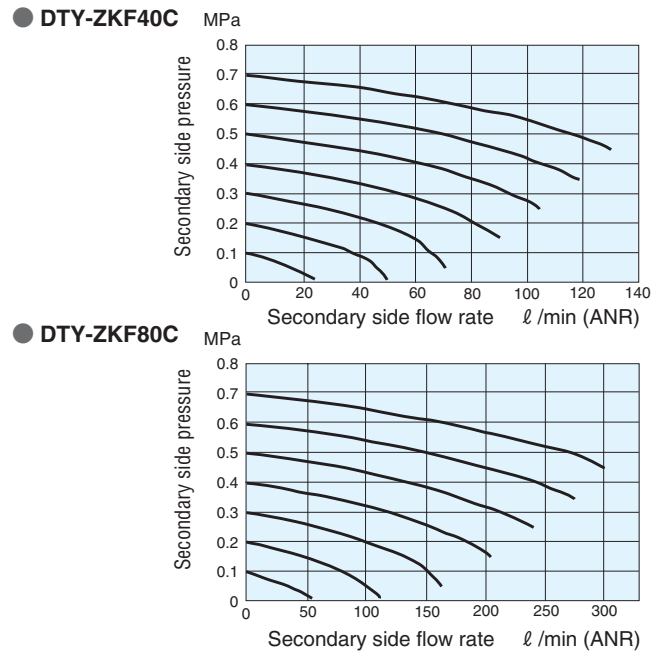

## Dimensions (mm)

### DTY-ZKF40C

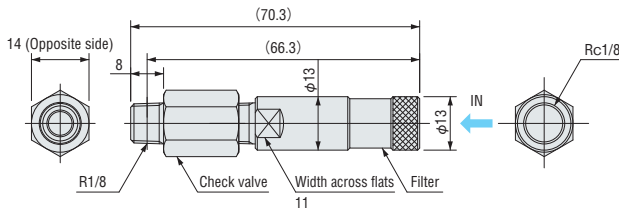

### DTY-ZKF80C

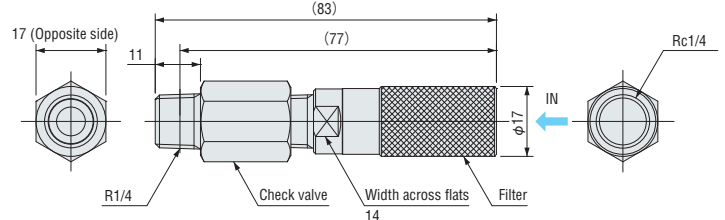

Note 1: DTY-ZKF40C can connect directly to the DTRY-ELL01 and DTY-ELK01-L ionizers. When mounting on the DTRY-ELL01, use a tightening torque of 60 to 70 N·cm. Over-tightening can damage the ionizer.

Note 2: DTY-ZKF80C cannot be connected directly to the ionizer.

## Handling Instructions and Precautions



### Mounting and Piping

1. Arrange piping so air flows in the direction of the black arrows on the label. (Do not use with air flow in the opposite direction.)

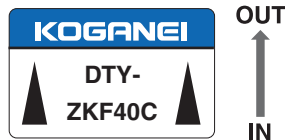

2. The filter IN ports (Rc1/8, Rc1/4) are made of aluminum alloy. Take care to avoid excessive force such as that caused by steel piping, etc.
3. The purpose of filters is to remove solid matter. Water vapor and oil should be removed beforehand.

#### Recommended circuit

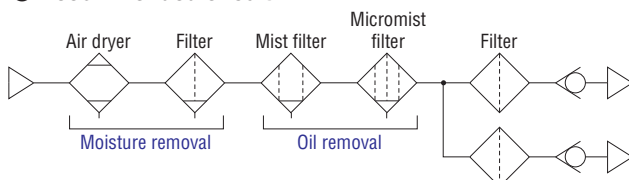

4. Check valve generates 50 dust particles or less with a particle diameter of 0.3 μm or greater at 1 cf/min.
- 5: Do not apply air intermittently (intermittent operation). Doing so can damage the filter membrane.



### CAUTION

#### Precautions when using in combination with an ionizer

Note the following precautions when using in combination with an ionizer.

1. Backflow of ozone and other corrosive gasses generated from the ionizer can cause deterioration of the filter membrane. Be sure to supply air first before applying the power source.
2. Check filters periodically and replace them when necessary.

## Warranty and General Disclaimer

### 1. Warranty Period

The warranty period for KOGANEI products is 180 days from the date of delivery.

### 2. Scope of Warranty and General Disclaimer

- (1) The KOGANEI product warranty covers individual products. When a product purchased from KOGANEI or from an authorized KOGANEI distributor malfunctions during the warranty period in a way that is attributable to KOGANEI responsibility, KOGANEI will repair or replace the product free of charge. Even if a product is still within the warranty period, its durability is determined by its operation cycles and other factors. Contact your nearest KOGANEI sales office or the KOGANEI overseas department for details.
- (2) KOGANEI shall not be held responsible for any losses or for any damage to other machinery caused by breakdown, loss of function, or loss of performance of KOGANEI products.
- (3) KOGANEI shall not be held responsible for any losses due to use or storage of the product in a way that is outside of the product specifications prescribed in KOGANEI catalogs and the instruction manual, and/or due to actions that violate the mounting, installation, adjustment, maintenance and other safety precautions.
- (4) KOGANEI shall not be held responsible for any losses caused by breakdown of the product due to factors outside the responsibility of KOGANEI, including but not limited to fire, natural disaster, the actions of third parties, and intentional actions or errors by you.

# Limited Warranty

KOGANEI CORP. warrants its products to be free from defects in material and workmanship subject to the following provisions.

**Warranty Period** The warranty period is 180 days from the date of delivery.

**Koganei Responsibility** If a defect in material or workmanship is found during the warranty period, KOGANEI CORP. will replace any part proved defective under normal use free of charge and will provide the service necessary to replace such a part.

**Limitations**

- This warranty is in lieu of all other warranties, expressed or implied, and is limited to the original cost of the product and shall not include any transportation fee, the cost of installation or any liability for direct, indirect or consequential damage or delay resulting from the defects.

- KOGANEI CORP. shall in no way be liable or responsible for injuries or damage to persons or property arising out of the use or operation of the manufacturer's product.

- This warranty shall be void if the engineered safety devices are removed, made inoperative or not periodically checked for proper functioning.

- Any operation beyond the rated capacity, any improper use or application, or any improper installation of the product, or any substitution upon it with parts not furnished or approved by KOGANEI CORP., shall void this warranty.

- This warranty covers only such items supplied by KOGANEI CORP. The products of other manufacturers are covered only by such warranties made by those original manufacturers, even though such items may have been included as the components.

The specifications are subject to change without notice.

URL <http://www.koganei.co.jp>

E-mail: [overseas@koganei.co.jp](mailto:overseas@koganei.co.jp)



## KOGANEI CORPORATION

### OVERSEAS DEPARTMENT

3-11-28, Midori-cho, Koganei City, Tokyo 184-8533, Japan  
Tel: 042-383-7271 Fax: 042-383-7276

### SHANGHAI KOGANEI INTERNATIONAL TRADING CORPORATION

Room 2606-2607, Tongda Venture Building No.1, Lane 600, Tianshan Road, Shanghai, 200051, China  
Tel: 021-6145-7313 Fax: 021-6145-7323

### KOGANEI-PORNCHAI CO., LTD.

89/174 Moo 3, Vibhavadee Rangsit Road, Talad Bangkhen, Laksi, Bangkok, 10210, Thailand  
Tel: 02-551-4025 Fax: 02-551-4015