

3 finger parallel style pneumatic grippers



Ordering code

6312.Ø.D

- 16
- 20
- 25
- 32
- 40
- 50
- 63
- 80
- 100
- 125

Construction characteristics

Body	aluminium
Piston	aluminium
Wedge	steel
Fingers	steel

Operational characteristics

Function	double acting
Fluid	Filtered air.
	No lubrication needed, if applied it shall be continuous.
Working pressure	2 - 6 bar (Ø16 - Ø20 - Ø25) - 1 - 6 bar (Ø32 - Ø125)
Working temperature	-5°C - +70°C
Maximum operating frequency	from Ø 16 to Ø 25, 120 cycles/minute from Ø 32 to Ø 63, 60 cycles/minute from Ø 80 to Ø 125, 30 cycles/minute

Overall dimensions Ø16 - Ø25

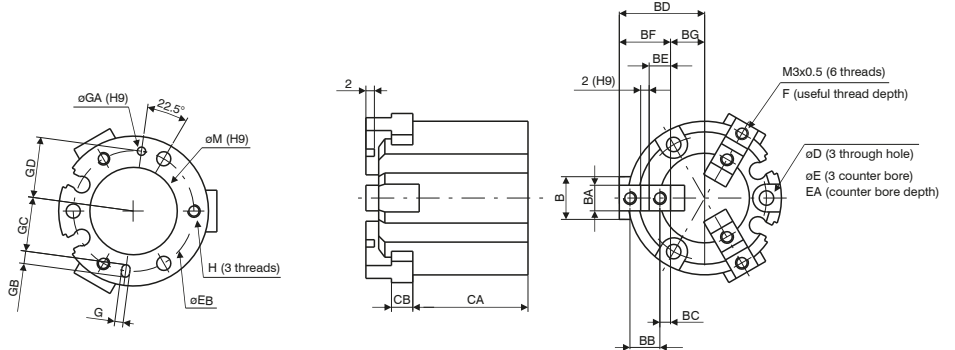

Bore	Ø16	Ø20	Ø25
ØA	30	36	42
AB	32	35	37
AC	35	38	40
B	8	10	12
BA ^{H9}	5	6	6
BB	6	7	8
BC	2	2,5	3
BD	open	17	20
	close	15	18
BE	4	5	6
BF	10	12	14
BG	open	7	8
	close	5	6
CA	25	27	28
CB	4	5	5
D	3,4	3,4	4,5
E	6,5	6,5	8
EA	8	9,5	10
EB	25	29	34
F	5	6	6
G ^{H9}		2	3
	Useful depth	2	3
ØGA ^{H9}		2	3
	Useful depth	2	3
GB	3	3	5
GC	11	13	14,5
GD	12,5	14,5	17
H	M3x0,5	M3x0,5	M4x0,7
	Useful depth	4,5	6
ØM ^{H9}		17	21
	Useful depth	1,5	1,5
N	M3x0,5	M5x0,8	M5x0,8
NA	11	13	15
Weight (g)	62	98	139

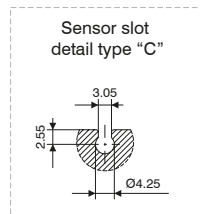
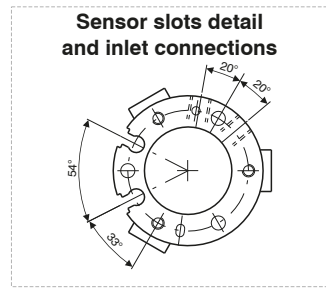
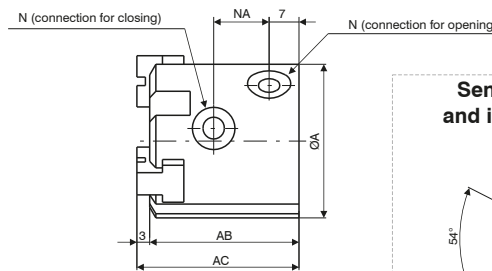

Overall dimensions Ø32 and Ø80

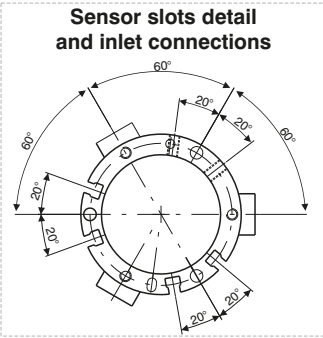
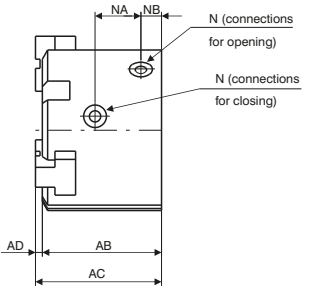
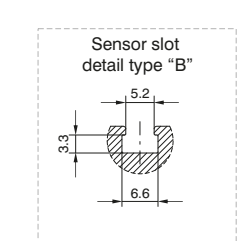
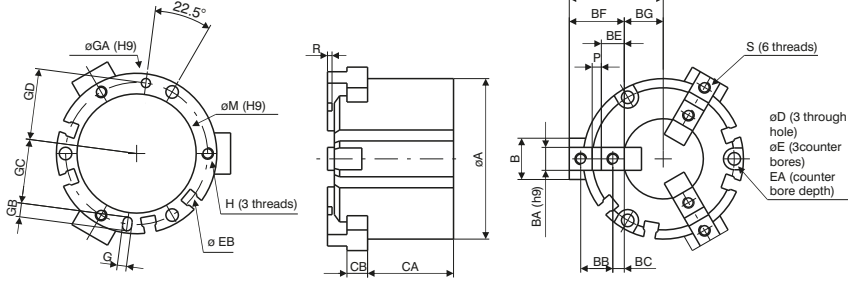

Bore	Ø32	Ø40	Ø50	Ø63	Ø80
ØA	52	62	70	86	106
AB	41	44	52	62	77
AC	44	47	55	66	82
AD	3	3	3	4	5
B	14	16	18	24	28
BA ^{H9}	8	8	10	12	14
BB	11	12	14	17	20
BC	4,5	4,5	5	5,5	6
BD	open: 32	open: 35	open: 41	open: 51	open: 63,5
BD	close: 28	close: 31	close: 35	close: 43	close: 53,5
BE	9	9	10	11	12
BF	20	21	24	28	32
BG	open: 12	open: 14	open: 17	open: 23	open: 31,5
BG	close: 8	close: 10	close: 11	close: 15	close: 21,5
CA	30,5	32	37,5	44	56
CB	6	7	9	11	12
D	4,5	5,5	5,5	6,6	6,6
E	8	9,5	9,5	11	11
EA	9	9	12	14	19
EB	44	53	62	76	95
H	M4x0,7	M5x0,8	M5x0,8	M6x1	M6x1
H	Useful depth: 6	Useful depth: 7,5	Useful depth: 10	Useful depth: 9	Useful depth: 12
G ^{H9}	3	4	4	5	6
G ^{H9}	Useful depth: 3	Useful depth: 4	Useful depth: 4	Useful depth: 5	Useful depth: 6
ØGA ^{H9}	3	4	4	5	6
ØGA ^{H9}	Useful depth: 3	Useful depth: 4	Useful depth: 4	Useful depth: 5	Useful depth: 6
GB	5	6	6	7	8
GC	19,5	23,5	28	34,5	43,5
GD	22	26,5	31	38	47,5
N	M5x0,8	M5x0,8	M5x0,8	M5x0,8	G1/8
ØM ^{H9}	34	42	52	65	82
ØM ^{H9}	Useful depth: 2	Useful depth: 2	Useful depth: 2	Useful depth: 2,5	Useful depth: 3
NA	16	17	20	22	27
NB	8	9	9	12	13,5
P ^{H9}	2	3	4	6	8
R	2	2	2	3	4
S	M4x0,7	M4x0,7	M5x0,8	M5x0,8	M6x1
S	Useful depth: 8	Useful depth: 8	Useful depth: 10	Useful depth: 10	Useful depth: 12
Weight (g)	240	354	542	1000	1850

PNEUMATIC ACTUATION 3

Overall dimensions Ø100 and Ø125

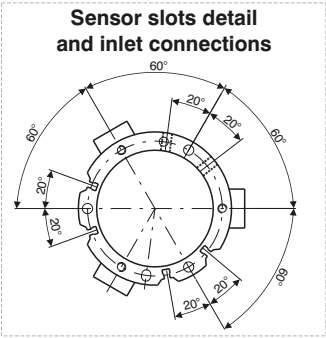
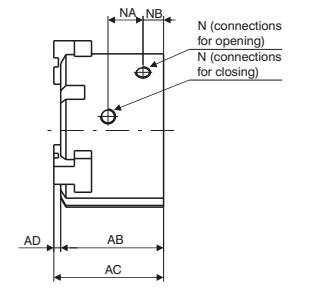
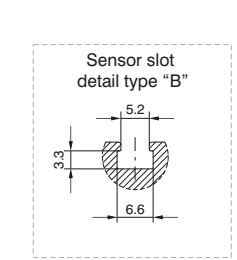
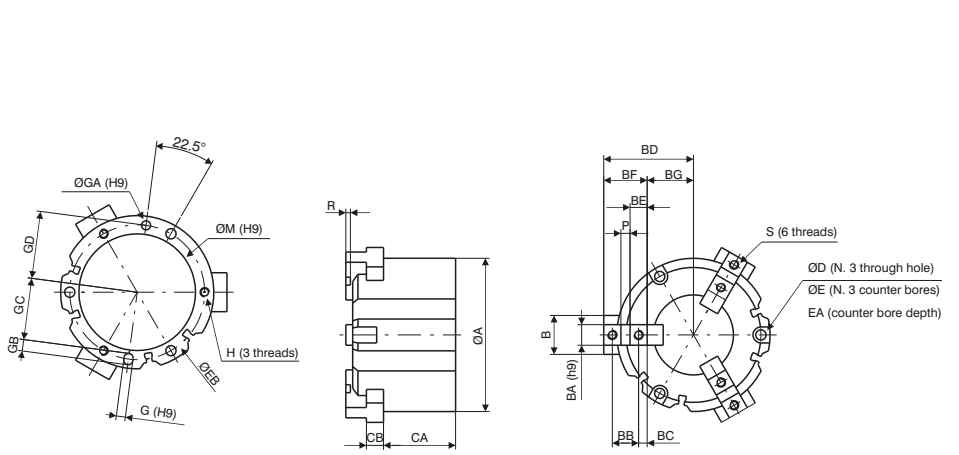

Bore	Ø100	Ø125
ØA	134	166
AB	90	114
AC	96	122
AD	6	8
B	34	40
BA ^{H9}	18	22
BB	23	31
BC	7,5	10,5
BD	open: 78	open: 98
BD	close: 66	close: 82
BE	15	21
BF	38	52
BG	open: 40	open: 46
BG	close: 28	close: 30
CA	63	84
CB	15	18
ØD	9	11
ØE	14	17,5
EA	21	34
EB	118	148
G ^{H9}	8	10
G ^{H9}	Useful depth: 6	Useful depth: 8
ØGA ^{H9}	8	10
ØGA ^{H9}	Useful depth: 6	Useful depth: 8
GB	10	12
GC	54	68
GD	59	74
H	M8x1,25	M10x1,5
H	Useful depth: 16	Useful depth: 20
ØM ^{H9}	102	130
ØM ^{H9}	Useful depth: 4	Useful depth: 6
N	G1/4	G3/8
NA	30,6	38
NB	18	23,5
P ^{H9}	8	10
R	4	6
S	M8x1,25	M10x1,5
S	Useful depth: 16	Useful depth: 20
Weight (g)	3360	6430

Gripping force (N)

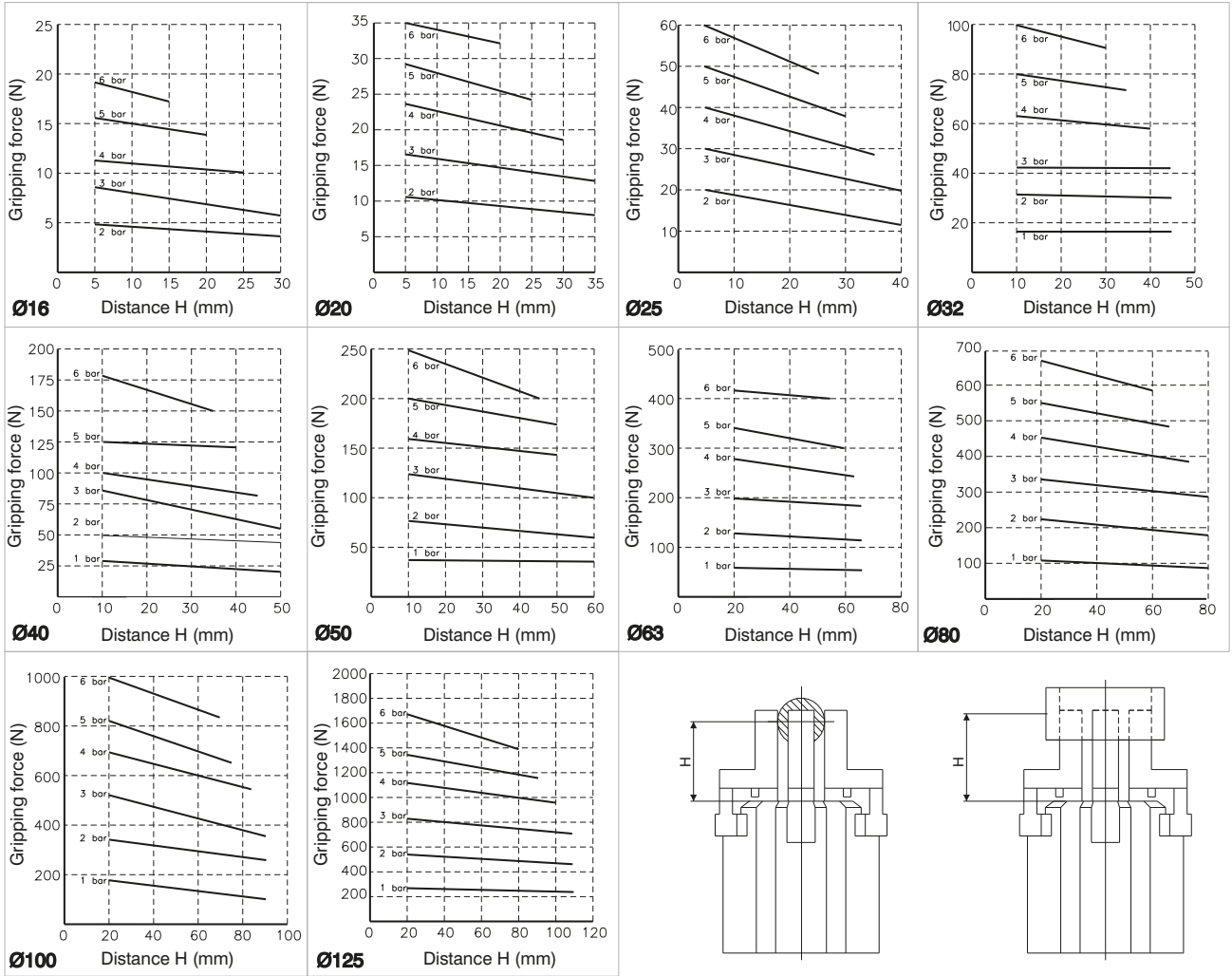

3

PNEUMATIC ACTUATION