



## Series 1200, Special performance microbore cylinders

### General

These microbore cylinders are not subject to a standard; they are single acting with a front spring, can be either hexagonal or round bodied and either completely threaded or threaded with a plain rod ending. They are available with M5 connections or with incorporated quick fittings.

### Construction characteristics

Body	nickel-plated brass
Rod / piston	stainless steel (C43 chromed)
Rod bushing	brass
Spring	stainless steel
Seal	NBR

### Technical characteristics

Fluid	Filtered air. No lubrication needed, if applied it shall be continuous.
Pressure	min. 3 bar - max. 7 bar
Temperature	min. -5°C - max. +70°C

"Attention: Dry air must be used for application below 0°C"

**Threaded body, round execution**

Ordering code	Bore	Stroke	A	B	C	D	T
<b>1213.6.5</b>	6	5	M10x1	3	5	30,5	4/2
<b>1213.6.10</b>	6	10	M10x1	3	5	35,5	4/2
<b>1213.6.20</b>	6	20	M10x1	3	5	49,5	4/2
<b>1213.8.5</b>	8	5	M12x1	3	6	28	4/2
<b>1213.10.3</b>	10	3	M15x1,5	5	1	44	4/2
<b>1213.10.5</b>	10	5	M15x1,5	5	5	40	4/2
<b>1213.10.10</b>	10	10	M15x1,5	5	12	44	4/2

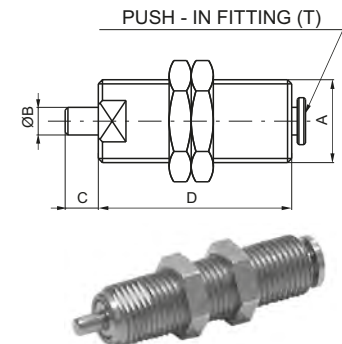

**Threaded body, hexagonal execution**

Ordering code	Description
<b>1213.Ø.stroke.C</b>	Single acting front spring
<b>1213.Ø.stroke.CF</b>	Single acting front spring threaded body

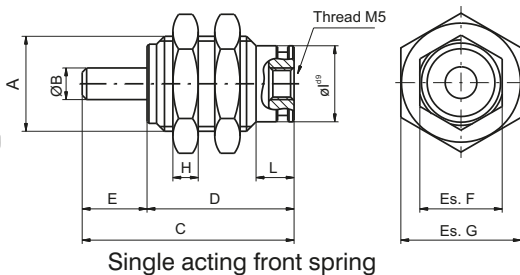

Single acting front spring

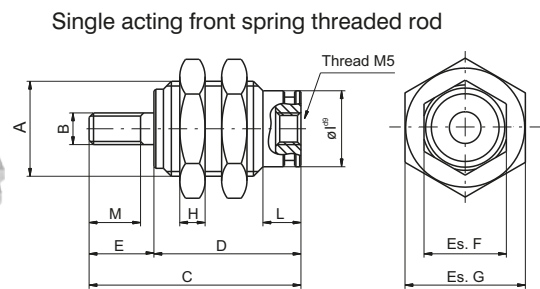

Single acting front spring threaded rod

Ø Cil.	Stroke	A	ØB	B	C	D	E	Es. F	Es. G	H	ØI	L	M
6	5	M10x1	Ø3	M3x0.5	27,5	18,5	9	9	12	3	Ø8,5	6	7
6	10	M10x1	Ø3	M3x0.5	34,5	25,5	9	9	12	3	Ø8,5	6	7
6	15	M10x1	Ø3	M3x0.5	41,5	32,5	9	9	12	3	Ø8,5	6	7
10	5	M15x1.5	Ø5	M4x0.7	32,5	20,5	12	13	19	4	Ø12	6	10
10	10	M15x1.5	Ø5	M4x0.7	39	27	12	13	19	4	Ø12	6	10
10	15	M15x1.5	Ø5	M4x0.7	46	34	12	13	19	4	Ø12	6	10
16	5	M22x1.5	Ø6	M5x0.8	37,5	23,5	14	20	27	5	Ø19	7	12
16	10	M22x1.5	Ø6	M5x0.8	43,5	29,5	14	20	27	5	Ø19	7	12
16	15	M22x1.5	Ø6	M5x0.8	50	36	14	20	27	5	Ø19	7	12

**Front fixing microbore cylinders**

Ordering code
<b>1273.4.10</b>

