



Series 1500 - Compact cylinders according to standard ISO 21287 “ECOMPACT”

General

These cylinders are built according to ISO 21287 standards. New barrel profile has two sensor slots on the three sides (Ø20 and Ø25 one slot) suitable for sensors 1580., MRS., MHS. series housing, without need for adaptors.

Versions with end stroke adjustable pneumatic cushioning are also available, allowing adjustments to deceleration and keeping the required overall dimensions according to ISO 21287.

For fixing operation is possible to use the four threaded holes on the end covers, or screws in body holes, alternatively all the fixing devices of UNITOP RU-P/6-P/7 (Ø20 and Ø25) and ISO 15552 (from Ø32 to Ø100) series.

Construction characteristics

Body	anodised aluminium
End cap	aluminium alloy casting painted
Bearing piston rod	sintered bronze
Piston rod	from Ø20 to Ø25 stainless steel from Ø32 to Ø100 C43 chromed (on request stainless steel)
Piston	from Ø20 to Ø40 acetal resin (aluminium on request), Ø50 and Ø100 aluminium (with FPM seals, aluminium piston for all standard diameters)
Seals	Standard: NBR oil resistant rubber, PUR piston rod seals (PUR or FPM seals available upon request)
Spring	stainless steel
Fixing screws	plated zinc steel

Operational characteristics

Fluid	Filtered air. No lubrication needed, if applied it shall be continuous.
Max. pressure	10 bar
Operating temperature	-5°C - +70°C with standard seals (magnetic or non magnetic piston) -30°C - +80°C with PUR seals (magnetic or non magnetic piston) -5°C - +80°C with FPM seals (magnetic piston) -5°C - +150°C with FPM seals (non magnetic piston)

Please follow the suggestions below to ensure a long life for these cylinders:

- use clean and lubricated air
- correct alignment during assembly with regard to the applied load so as to avoid radial components or bending the rod.
- avoid high speeds together with long strokes and heavy loads: this would produce kinetic energy which the cylinder cannot absorb, especially if used as a limit stop (in this case use mechanical stop device and aluminium piston)
- evaluate the environmental characteristics of cylinder used (high temperature, hard atmosphere, dust, humidity etc.)

Please note: air must be dried for applications with lower temperature.

Use hydraulic oils H class (ISO VG32) for correct continued lubrication.

Our Technical Department will be glad to help.

Stroke tolerance, minimum and maximum spring loads and cushioning length

Bore (mm)	Stroke tolerance (mm)	Minimum and maximum springs load (N)		Cushioning length (mm)
		min.	max.	
Ø20	+1.5 / 0 mm	10.8	19.6	/
Ø25		16.7	22.6	5
Ø32	+2 / 0 mm	19.6	25.5	6.5
Ø40		25.5	42.2	8
Ø50		44.1	96.3	7.5
Ø63	+2.5 / 0mm	44.1	96.3	7.5
Ø80		63.8	100.1	8
Ø100		107.9	193.3	12



Standard stroke

**DOUBLE ACTING
BASIC version
and
THROUGH ROD CYLINDER
version**

Bore	Stroke																												
	5	10	15	20	25	30	35	40	45	50	55	60	65	70	75	80	100	125	150	160	200	250	300	320	350	400	450	500	
	WITHOUT CUSHIONING DEVICE																												
Ø20	●	●	●	●	●	●	●	●	●	●	●	●	●	●	●	●	●	●	●	●	●	●	●	●	●	●	●	●	●
Ø25	●	●	●	●	●	●	●	●	●	●	●	●	●	●	●	●	●	●	●	●	●	●	●	●	●	●	●	●	●
Ø32	●	●	●	●	●	●	●	●	●	●	●	●	●	●	●	●	●	●	●	●	●	●	●	●	●	●	●	●	●
Ø40	●	●	●	●	●	●	●	●	●	●	●	●	●	●	●	●	●	●	●	●	●	●	●	●	●	●	●	●	●
Ø50	●	●	●	●	●	●	●	●	●	●	●	●	●	●	●	●	●	●	●	●	●	●	●	●	●	●	●	●	●
Ø63	●	●	●	●	●	●	●	●	●	●	●	●	●	●	●	●	●	●	●	●	●	●	●	●	●	●	●	●	●
Ø80	●	●	●	●	●	●	●	●	●	●	●	●	●	●	●	●	●	●	●	●	●	●	●	●	●	●	●	●	●
Ø100	●	●	●	●	●	●	●	●	●	●	●	●	●	●	●	●	●	●	●	●	●	●	●	●	●	●	●	●	●
	WITH CUSHIONING DEVICE																												
Ø20																													
Ø25					●	●	●	●	●	●	●	●	●	●	●	●	●	●	●	●	●	●	●	●	●	●	●	●	●
Ø32					●	●	●	●	●	●	●	●	●	●	●	●	●	●	●	●	●	●	●	●	●	●	●	●	●
Ø40					●	●	●	●	●	●	●	●	●	●	●	●	●	●	●	●	●	●	●	●	●	●	●	●	●
Ø50					●	●	●	●	●	●	●	●	●	●	●	●	●	●	●	●	●	●	●	●	●	●	●	●	●
Ø63					●	●	●	●	●	●	●	●	●	●	●	●	●	●	●	●	●	●	●	●	●	●	●	●	●
Ø80					●	●	●	●	●	●	●	●	●	●	●	●	●	●	●	●	●	●	●	●	●	●	●	●	●
Ø100					●	●	●	●	●	●	●	●	●	●	●	●	●	●	●	●	●	●	●	●	●	●	●	●	●

**DOUBLE ACTING
THROUGH ROD CYLINDER
BORED version**

Bore	Stroke																															
	5	10	15	20	25	30	35	40	45	50	55	60	65	70	75	80	25	30	35	40	45	50	55	60	65	70	75	80				
	WITHOUT CUSHIONING DEVICE																WITH CUSHIONING DEVICE															
Ø20	●	●	●	●	●	●	●	●	●	●	●	●	●	●	●	●																
Ø25	●	●	●	●	●	●	●	●	●	●	●	●	●	●	●	●	●	●	●	●	●	●	●	●	●	●	●	●	●			
Ø32	●	●	●	●	●	●	●	●	●	●	●	●	●	●	●	●	●	●	●	●	●	●	●	●	●	●	●	●	●			
Ø40	●	●	●	●	●	●	●	●	●	●	●	●	●	●	●	●	●	●	●	●	●	●	●	●	●	●	●	●	●			
Ø50	●	●	●	●	●	●	●	●	●	●	●	●	●	●	●	●	●	●	●	●	●	●	●	●	●	●	●	●	●			
Ø63	●	●	●	●	●	●	●	●	●	●	●	●	●	●	●	●	●	●	●	●	●	●	●	●	●	●	●	●	●			
Ø80	●	●	●	●	●	●	●	●	●	●	●	●	●	●	●	●	●	●	●	●	●	●	●	●	●	●	●	●	●			
Ø100	●	●	●	●	●	●	●	●	●	●	●	●	●	●	●	●	●	●	●	●	●	●	●	●	●	●	●	●	●			

**DOUBLE ACTING version
WITH NON-ROTATING DEVICE**

Bore	Stroke																															
	5	10	15	20	25	30	35	40	45	50	55	60	65	70	75	80	25	30	35	40	45	50	55	60	65	70	75	80				
	WITHOUT CUSHIONING DEVICE																WITH CUSHIONING DEVICE															
Ø20	●	●	●	●	●	●	●	●	●	●	●	●	●	●	●	●																
Ø25	●	●	●	●	●	●	●	●	●	●	●	●	●	●	●	●	●	●	●	●	●	●	●	●	●	●	●	●	●			
Ø32	●	●	●	●	●	●	●	●	●	●	●	●	●	●	●	●	●	●	●	●	●	●	●	●	●	●	●	●	●			
Ø40	●	●	●	●	●	●	●	●	●	●	●	●	●	●	●	●	●	●	●	●	●	●	●	●	●	●	●	●	●			
Ø50	●	●	●	●	●	●	●	●	●	●	●	●	●	●	●	●	●	●	●	●	●	●	●	●	●	●	●	●	●			
Ø63	●	●	●	●	●	●	●	●	●	●	●	●	●	●	●	●	●	●	●	●	●	●	●	●	●	●	●	●	●			
Ø80	●	●	●	●	●	●	●	●	●	●	●	●	●	●	●	●	●	●	●	●	●	●	●	●	●	●	●	●	●			
Ø100	●	●	●	●	●	●	●	●	●	●	●	●	●	●	●	●	●	●	●	●	●	●	●	●	●	●	●	●	●			

**SINGLE ACTING
version**

Bore	Stroke				
	5	10	15	20	25
Ø20	●	●	●	●	●
Ø25	●	●	●	●	●
Ø32	●	●	●	●	●
Ø40	●	●	●	●	●
Ø50	●	●	●	●	●
Ø63	●	●	●	●	●
Ø80	●	●	●	●	●
Ø100	●	●	●	●	●

PNEUMATIC ACTUATION 3

BASIC version
double and single acting



Ø20 and Ø25

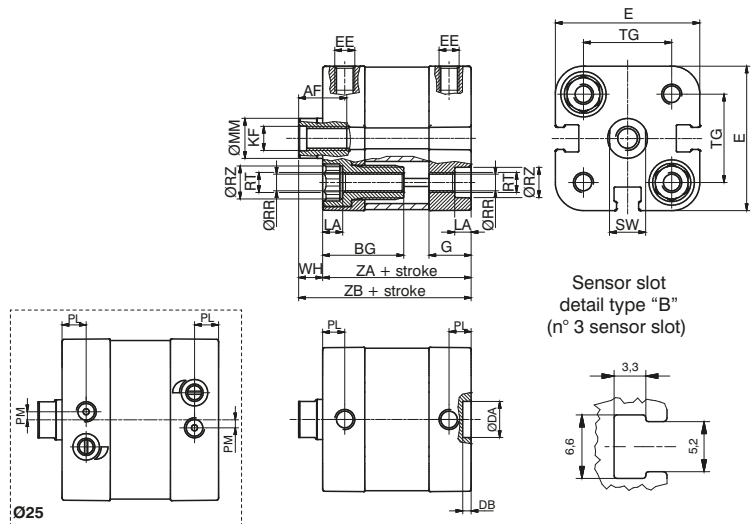

from Ø32 to Ø63

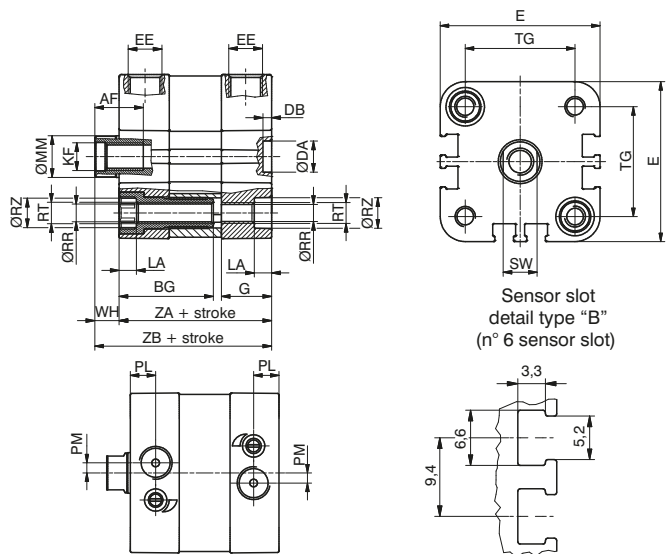

Ø80 and Ø100

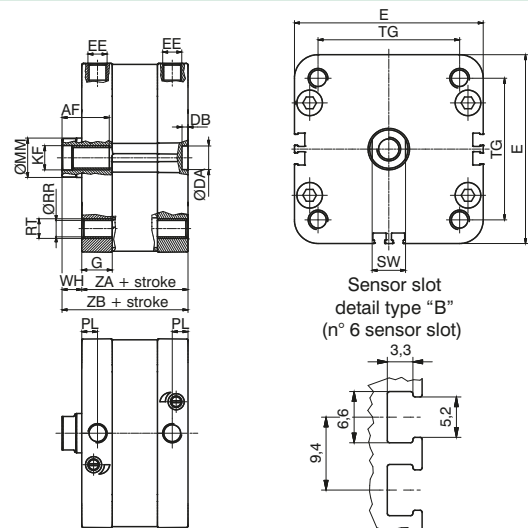

THROUGH ROD CYLINDER version
double and single acting

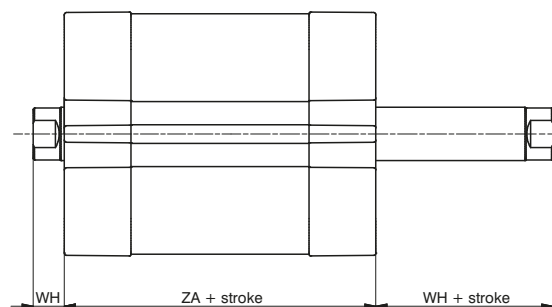

3 PNEUMATIC ACTUATION

TANDEM version

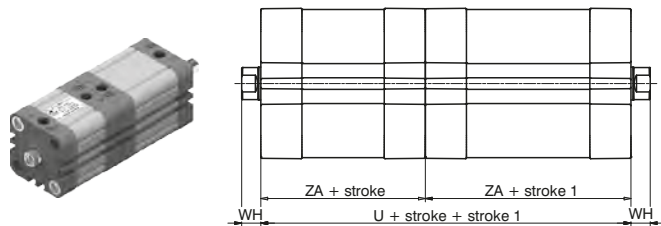

Tandem with opposed rods

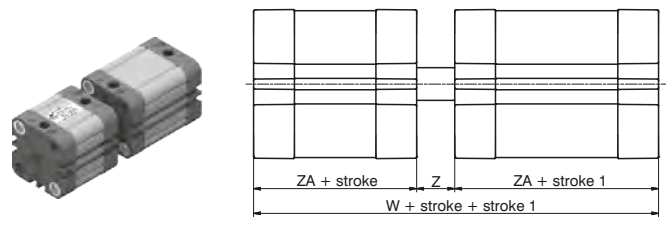

Opposed tandem with common rods

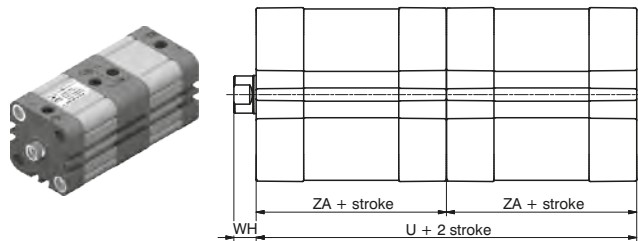

Tandem push with common rod

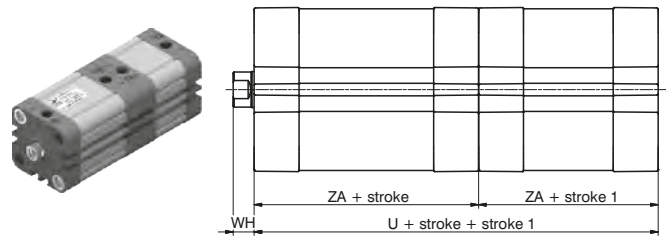

Tandem push with independent rod

Basic and Through rod version

Ordering code

TANDEM version (magnetic pistons)

- 15 . Ø . stroke . .
- 1 = magnetic piston, Double acting
 - 2 = magnetic piston, Single acting with front spring
 - 3 = magnetic piston, Single acting with rear spring
 - 4 = non magnetic piston, Double acting
 - 5 = non magnetic piston, Single acting with front spring
 - 6 = non magnetic piston, Single acting with rear spring
- 01 = Basic, female threaded rod
 - 02 = Basic, male threaded rod
 - 03 = through rod, female threaded rod
 - 04 = through rod, male threaded rod
 - ** 05 = through rod, bored female threaded rod
 - 06 = through rod, bored male threaded rod
 - 07 = with non-rotating device
 - 08 = through rod, female threaded rod, with non-rot. device on one side ***
 - 09 = through rod, male threaded rod, with non-rot. device on one side ***
- 0 = NBR seals and C43 chromed plated rod*
 - 1 = NBR seals and stainless steel rod (starting from bore Ø32)
 - 4 = PUR seals and C43 chromed plated rod *
 - 5 = PUR seals and stainless steel rod (starting from bore Ø32)
 - 6 = FPM seals and C43 chromed plated rod*
 - 7 = FPM seals and stainless steel rod (starting from bore Ø32)
- * (Ø20 and Ø25 stainless steel)
- 4 = Non-cushioned versions (mechanical cushioning only)
 - 5 = Versions with adjustable end of stroke cushioning system (from Ø25)

** It is possible to order the Ø20, Ø25, Ø32 and Ø40 cylinders with an aluminium piston by replacing the '0' with 'K' in the ordering code.
Example: 1540.20.10.01.1 (Acetyl Resin Piston)

1540.20.10.K1.1 (Aluminium Piston version)

*** for single acting version, the spring is on the anti-rotation side

Table of dimensions

Bore	Ø20	Ø25	Ø32	Ø40	Ø50	Ø63	Ø80	Ø100
AF (min)	12	12	14	14	18	18	24	24
BG	20	20	16	16	16	16	/	/
DA (H9) Ø	9	9	9	9	12	12	12	12
DB (+0.1/0)	2.1	2.1	2.5	2.5	2.6	2.6	3	3
E (max)	36	40.5	47.5	55	66	78	96	116
EE	M5	M5	G1/8	G1/8	G1/8	G1/8	G1/8	G1/8
G	10.5	12	14.5	15	15	15	15.5	18.5
KF	M6	M6	M8	M8	M10	M10	M12	M12
LA (0/-0.1)	4.1	4.1	5	5	5	5	/	/
MM (f7) Ø	10	10	12	12	16	16	20	25
PL (+0.1/0)	5.5	6	7.5	8	8	8	8	8
PM	/	2	3	/	/	/	/	/
RR (min) Ø	4.1	4.1	5.1	5.1	6.6	6.6	8.4	8.4
RT	M5	M5	M6	M6	M8	M8	M10	M10
RZ (min) Ø	7.5	7.5	8.5	8.5	10.5	10.5	/	/
SW (0/-0.1)	9	9	10	10	13	13	17	22
TG (±0.2)	22	26	32.5	38	46.5	56.5	72	89
U	74	78	88	90	90	98	108	134
W	83	89	100	103	105	113	124	154
WH (±1)	6	6	7	7	8	8	10	10
Z	9	11	12	13	15	15	16	20
ZA (±0.5)	37	39	44	45	45	49	54	67
ZB (+1/0)	43	45	51	52	53	57	64	77
Weight stroke	105	110	200	270	420	550	760	1400
gr. every 5mm	10	10.5	13	17	23.5	27	37	51

- 15 . Ø . stroke . (stroke 1) . .
- C = female threaded rod
 - G = male threaded rod
 - H = with through rod and female threaded rod
 - R = with through rod and male threaded rod
 - N = with non-rotating device
 - B = female threaded rod
 - F = male threaded rod
 - M = with non-rotating device
 - P = with through rod and female threaded rod
 - Q = with through rod and male threaded rod
 - D = **Opposed tandem with common rod**
 - A = female threaded rod
 - E = male threaded rod
 - L = with non-rotating device on both ends
- 0 = NBR seals and C43 chromed plated rod*
 - 1 = NBR seals and stainless steel rod (starting from bore Ø32)
 - 4 = PUR seals and C43 chromed plated rod*
 - 5 = PUR seals and stainless steel rod (starting from bore Ø32)
 - 6 = FPM seals and C43 chromed plated rod*
 - 7 = FPM seals and stainless steel rod (starting from bore Ø32)
- * (Ø20 and Ø25 stainless steel)
- 4 = Non-cushioned version (mechanical cushioning only)
 - 5 = Versions with adjustable end of stroke cushioning system (from Ø25)

Seals compounds scheme: **NBR** oil resistant nitrilic rubber
PUR: polyurethane seals **FPM**: fluoropolymer rubber seals

3 PNEUMATIC ACTUATION

► Basic version male piston rod

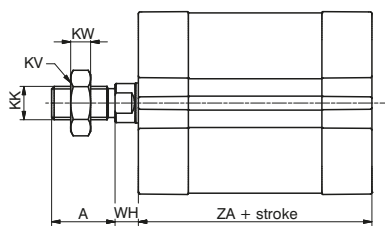

► Through rod version male rod

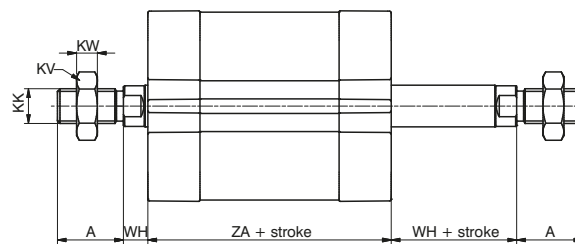

► Through rod version bored female piston rod

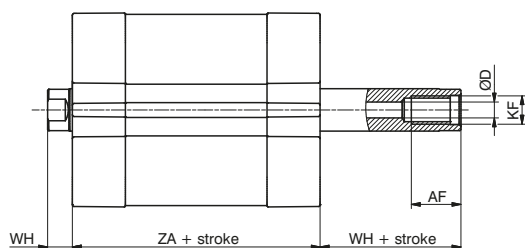

► Through rod version bored male piston rod

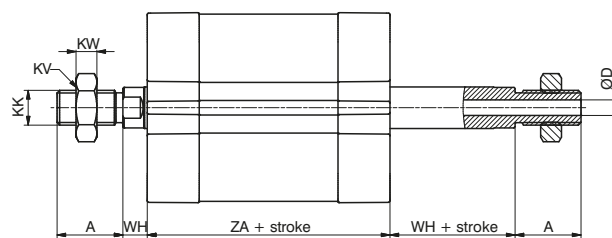

► Non-rotating version

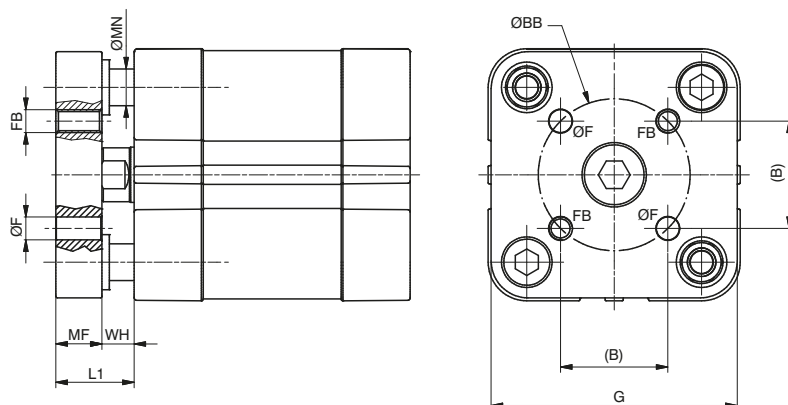

Bore	Ø20	Ø25	Ø32	Ø40	Ø50	Ø63	Ø80	Ø100
A (0/-0,5)	16	16	19	19	22	22	28	28
AF (min)	12	12	14	14	18	18	24	24
B	12	15,6	19,8	23,3	29,7	35,4	46	56,6
BB (±0,1) Ø	17	22	28	33	42	50	65	80
D Ø	3	3,8	4,5	4,5	6	6	8	10
F (+0,1/0) Ø	4	5	5	5	6	6	8	10
FB	M4	M5	M5	M5	M6	M6	M8	M10
G	35	39,5	45	52	65	75	95	115
KF	M6	M6	M8	M8	M10	M10	M12	M12
KK	M8x1,25	M8x1,25	M10x1,25	M10x1,25	M12x1,25	M12x1,25	M16x1,5	M16x1,5
KV	13	13	17	17	19	19	24	24
KW	5	5	6	6	7	7	8	8
L1	14	14	17	17	20	20	24	24
MF (+0,1/0)	8	8	10	10	12	12	14	14
MN (f 7) Ø	6	6	8	8	10	10	12	12
WH (±1)	6	6	7	7	8	8	10	10
ZA (±0,5)	37	39	44	45	45	49	54	67



Sensor and piston rod accessories

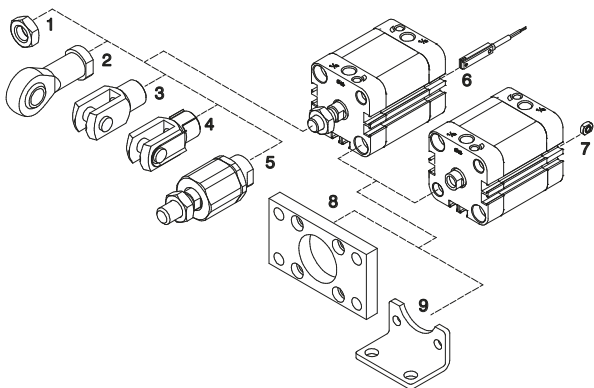

Pos.	Description	Ordering code	
		Aluminium	Steel
1	Rod lock nut	1200.20.06	(Ø20-Ø25)
		1320.32.18F	(Ø32-Ø40)
		1320.40.18F	(Ø50-Ø63)
		1320.50.18F	(Ø80-Ø100)
2	Ball joint	1200.20.32F	(Ø20-Ø25)
		1320.32.32F	(Ø32-Ø40)
		1320.40.32F	(Ø50-Ø63)
		1320.50.32F	(Ø80-Ø100)
3	Fork	1200.20.04	(Ø20-Ø25)
		1320.32.13F	(Ø32-Ø40)
		1320.40.13F	(Ø50-Ø63)
		1320.50.13F	(Ø80-Ø100)
4	Fork with clips	1200.20.04/1	(Ø20-Ø25)
		1320.32.13/1F	(Ø32-Ø40)
		1320.40.13/1F	(Ø50-Ø63)
		1320.50.13/1F	(Ø80-Ø100)
5	Self-aligning joint	1200.20.33F	(Ø20-Ø25)
		1320.32.33F	(Ø32-Ø40)
		1320.40.33F	(Ø50-Ø63)
		1320.50.33F	(Ø80-Ø100)
6	Sensors	(See chapter 6 magnetic sensors)	
7	Valves direct mounting bolt	1500.20F	(Ø20 - Ø100)

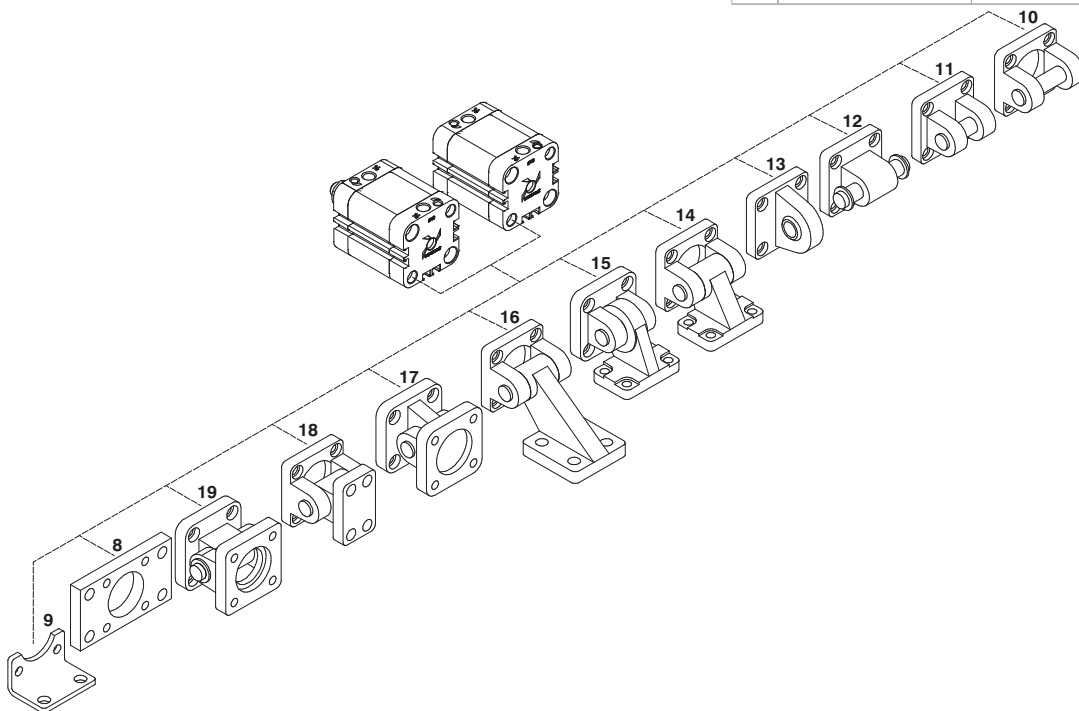

Fixing

Pos.	Description	Ordering code	
		Aluminium	Steel
8	Flange (MF2)	/	1540.Ø.03F (Ø20 - Ø25)
		/	1380.Ø.03F (Ø32 - Ø100)
9	Foot (MS1)	/	1540.Ø.05/1F (Ø20 - Ø100)
		/	1320.Ø.20F (Ø32 - Ø100)
10	Rear female clevis (MP2)	1380.Ø.09F (Ø32 - Ø100)	1320.Ø.20F (Ø32 - Ø100)
11	Narrow rear female trunnion (AB6)	1380.Ø.30F (Ø32 - Ø100)	1320.Ø.29F (Ø32 - Ø100)
12	Rear male clevis (MP4)	1580.Ø.09/1F (Ø20 - Ø25)	1580.Ø.09/2F (Ø20 - Ø25)
		1380.Ø.09/1F (Ø32 - Ø100)	1320.Ø.21F (Ø32 - Ø100)
13	Rear male clevis (with jointed head - MP6)	1380.Ø.15F (Ø32 - Ø100)	1320.Ø.25F (Ø32 - Ø100)
14	Square angle trunnion (AB7)	1380.Ø.35F (Ø32 - Ø100)	1320.Ø.23F (Ø32 - Ø100)
15	Square angle trunnion (with jointed head)		1320.Ø.27F (Ø32 - Ø100)
16	Square angle trunnion (not specified by ISO 15552)	1380.Ø.11F (Ø32 - Ø100)	/
17	Standard trunnion (with jointed head)	1380.Ø.36F (Ø32 - Ø100)	1320.Ø.26F (Ø32 - Ø100)
18	Standard trunnion (not specified by ISO 15552)	1380.Ø.10F (Ø32 - Ø100)	/
19	Complete standard trunnion	/	1320.Ø.22F (Ø32 - Ø100)

Rod lock nut

Ordering code	
Ø20-Ø25:	1200.20.32F
Ø32-Ø40:	1320.32.32F
Ø50-Ø63:	1320.40.32F
Ø80-Ø100:	1320.50.32F

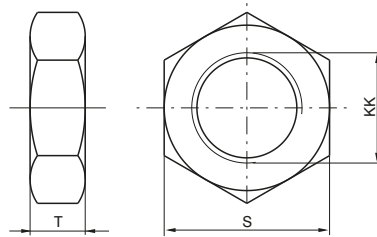

Bore	Ø20	Ø25	Ø32	Ø40	Ø50	Ø63	Ø80	Ø100
S	13	13	17	17	19	19	24	24
T	5	5	6	6	7	7	8	8
KK	M8x1.25	M8x1.25	M10x1.25	M10x1.25	M12x1.25	M12x1.25	M16x1.5	M16x1.5
Weight g	12	12	15	15	20	20	20	20

Ball joint

Ordering code	
Ø20-Ø25:	1200.20.32F
Ø32-Ø40:	1320.32.32F
Ø50-Ø63:	1320.40.32F
Ø80-Ø100:	1320.50.32F

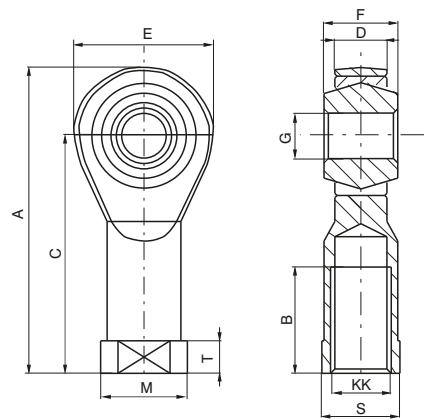

Bore	Ø20	Ø25	Ø32	Ø40	Ø50	Ø63	Ø80	Ø100
A	48	48	57	57	66	66	85	85
B	16	16	20	20	22	22	28	28
C	36	36	43	43	50	50	64	64
D (-0,1)	9	9	10,5	10,5	12	12	15	15
E	24	24	28	28	32	32	42	42
F	12	12	14	14	16	16	21	21
G (H7)	8	8	10	10	12	12	16	16
KK	M8x1,25	M8x1,25	M10x1,25	M10x1,25	M12x1,25	M12x1,25	M16x1,5	M16x1,5
M	16	16	19	19	22	22	27	27
S	14	14	17	17	19	19	22	22
T	5	5	6,5	6,5	6,5	6,5	8	8
Weight g	46	46	76	76	110	110	220	220

Fork

Ordering code	
Ø20-Ø25:	1200.20.04
Ø32-Ø40:	1320.32.13F
Ø50-Ø63:	1320.40.13F
Ø80-Ø100:	1320.50.13F

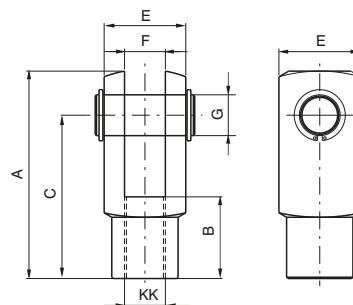

Bore	Ø20	Ø25	Ø32	Ø40	Ø50	Ø63	Ø80	Ø100
A	42	42	52	52	62	62	83	83
B	16	16	20	20	24	24	32	32
C	32	32	40	40	48	48	64	64
E	16	16	20	20	24	24	32	32
F (B12)	8	8	10	10	12	12	16	16
G	8	8	10	10	12	12	16	16
KK	M8x1,25	M8x1,25	M10x1,25	M10x1,25	M12x1,25	M12x1,25	M16x1,5	M16x1,5
Weight g	45	45	100	100	140	140	340	340

Fork with clips

Ordering code

Ø20-Ø25: **1200.20.04/1**
 Ø32-Ø40: **1320.32.13/1F**
 Ø50-Ø63: **1320.40.13/1F**
 Ø80-Ø100: **1320.50.13/1F**

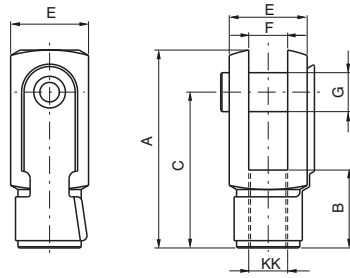

Bore	Ø20	Ø25	Ø32	Ø40	Ø50	Ø63	Ø80	Ø100
A	42	42	52	52	62	62	83	83
B	16	16	20	20	24	24	32	32
C	32	32	40	40	48	48	64	64
E	16	16	20	20	24	24	32	32
F (B12)	8	8	10	10	12	12	16	16
G	8	8	10	10	12	12	16	16
KK	M8x1,25	M8x1,25	M10x1,25	M10x1,25	M12x1,25	M12x1,25	M16x1,5	M16x1,5
Weight g	45	45	100	100	140	140	340	340

Self-aligning joint

Ordering code

Ø20-Ø25: **1200.20.33F**
 Ø32-Ø40: **1320.32.33F**
 Ø50-Ø63: **1320.40.33F**
 Ø80-Ø100: **1320.50.33F**

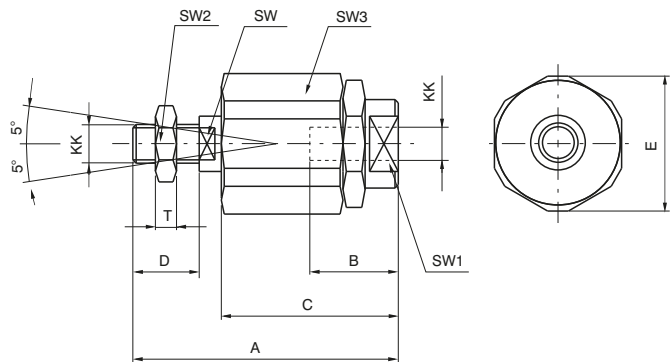

Bore	Ø20	Ø25	Ø32	Ø40	Ø50	Ø63	Ø80	Ø100
A	57	57	71	71	75	75	103	103
B	20	20	20	20	20	20	32	32
C	33	33	46	46	46	46	63	63
D	20	20	20	20	24	24	32	32
E	19	19	32	32	32	32	45	45
KK	M8x1,25	M8x1,25	M10x1,25	M10x1,25	M12x1,25	M12x1,25	M16x1,5	M16x1,5
SW	7	7	12	12	12	12	20	20
SW1	11	11	19	19	19	19	27	27
SW2	13	13	17	17	19	19	24	24
SW3	17	17	30	30	30	30	41	41
T	5	5	6	6	7	7	8	8
Weight g	60	60	220	220	230	230	660	660

Valves direct mounting nut

Ordering code

1500.20.F

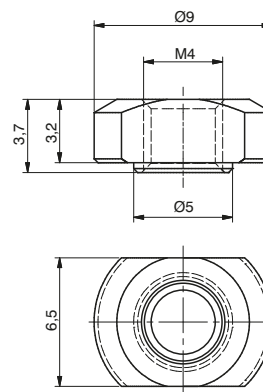
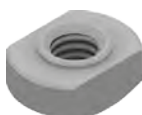

Flange (MF2)

Ordering code
Ø20-Ø25: 1540.Ø.03F
Ø32-Ø100: 1380.Ø.03F

The kit comprises:
n°1 flange (plated zinc steel)
n°4 screws (plated zinc steel)

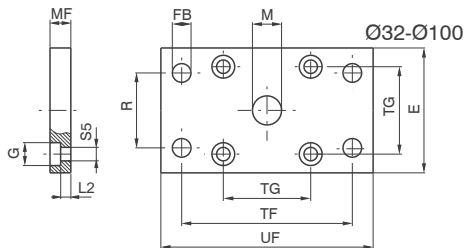
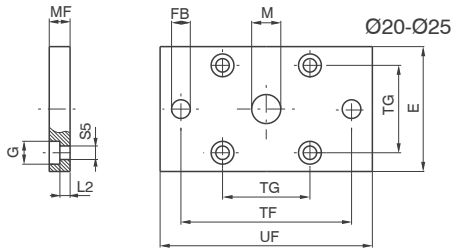
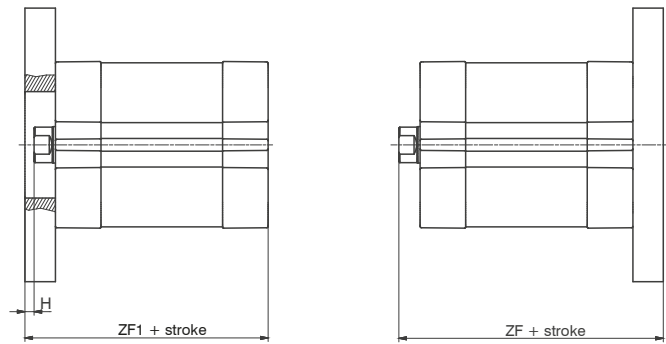

Bore	Ø20	Ø25	Ø32	Ø40	Ø50	Ø63	Ø80	Ø100
E	35	40	45	52	65	75	95	115
FB (H 13)	6.6	6.6	7	9	9	9	12	14
G	9.5	9.5	10.5	10.5	15	15	18	18
M (H 11)	16	16	30	35	40	45	45	55
MF (JS 14)	8	8	10	10	12	12	16	16
R (JS 14)	/	/	32	36	45	50	63	75
TF (JS 14)	55	60	64	72	90	100	126	150
TG	22	26	32.5	38	46.5	56.5	72	89
UF	70	75	80	90	110	120	150	170
ZF	51	53	130	145	155	170	190	205
ZF1	45	47	54	55	57	61	70	83
H	2	2	3	3	4	4	6	6
L2	3	3	5	5	6.5	6.5	8	8
S5	5.5	5.5	6.6	6.6	9	9	11	11
Weight g	125	160	190	250	480	620	1430	1990

Foot (MS1)

Ordering code
1540.Ø.05/1F

The kit comprises:
n°1 foot (plated zinc steel)
n°2 screws (plated zinc steel)

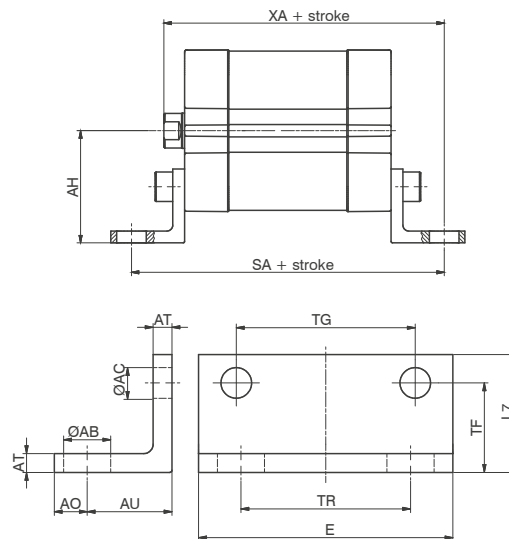

Bore	Ø20	Ø25	Ø32	Ø40	Ø50	Ø63	Ø80	Ø100
AB (H 14)	7	7	7	10	10	10	12	14.5
AC	5.5	5.5	6.5	6.5	8.5	8.5	10.5	10.5
AH	27	29	33.5	38	45	50	63	74
AO (max)	7	7	7	7	9	9	11	13
AT (±0.5)	4	4	4	4	5	5	6	6
AU (±0.2)	16	16	16	18	21	21	26	27
E (max)	35.5	39.5	46.5	54	65	77	95	115
L7	20	20	25	25	30	30	40	45
TF (±0.1)	16	16	17.25	19	21.75	21.75	27	29.5
TG (±0.2)	22	26	32.5	38	46.5	56.5	72	89
TR (JS 14)	22	26	32	36	45	50	63	75
SA	69	71	76	81	87	91	106	121
XA	59	61	67	70	74	78	90	104
Weight g	40	45	60	70	130	160	300	405

Rear female clevis (MP2)

Ordering code

Aluminium: **1380.Ø.09F**

Steel: **1320.Ø.20F**

The kit comprises:

n°1 clevis (steel or painted aluminium)

n°4 screws (plated zinc steel)

n°1 pin (plated zinc steel)

n°2 circlips (steel)

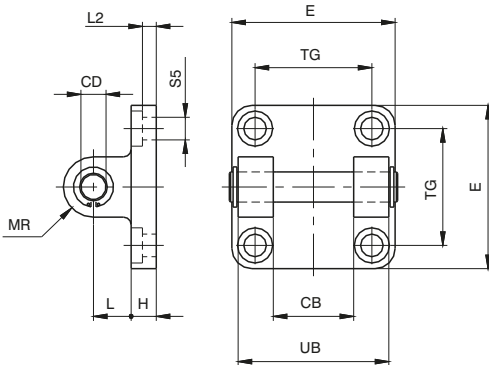
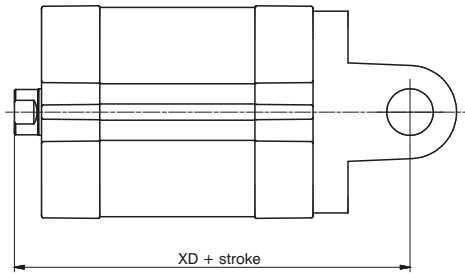

Bore		Ø32	Ø40	Ø50	Ø63	Ø80	Ø100
CB (H 14)		26	28	32	40	50	60
CD		10	12	12	16	16	20
E	Aluminium	45	52	65	75	95	115
	Steel	45	55	65	75	95	115
H	Aluminium	9	9	11	11	14	14
	Steel	10	10	10	12	14	16
L	Aluminium	13	16	16	21	22	27
	Steel	12	15	17	20	22	25
MR		10	12	12	16	16	20
TG		32.5	38	46.5	56.5	72	89
UB (h14)		45	52	60	70	90	110
XD		73	77	80	83	100	118
L2(±0.5)		5.5	5.5	6.5	6.5	10	10
S5		6.6	6.6	9	9	11	11
Weight	Aluminium	80	130	185	310	530	910
	Steel	180	290	400	670	1160	2000

Narrow rear female trunnion (AB6)

Ordering code

Aluminium: **1380.Ø.30F**

Steel: **1320.Ø.29F**

The kit comprises:

n°1 clevis (plated zinc steel or painted)

n°4 screws (plated zinc steel)

n°1 pin (plated zinc steel) complete with elastic pin and ring

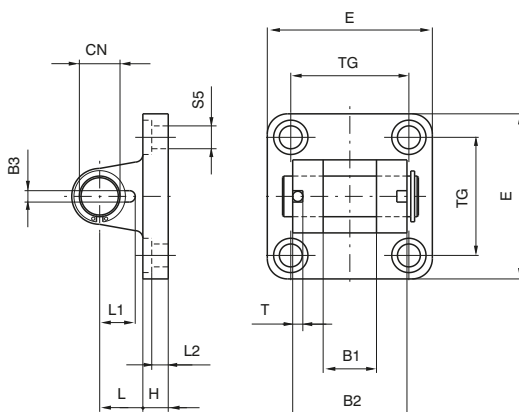
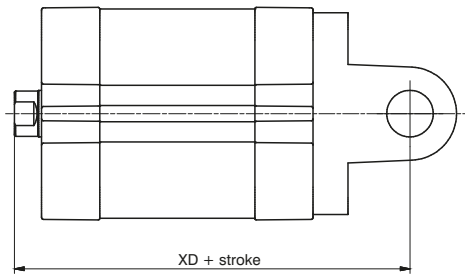

Bore		Ø32	Ø40	Ø50	Ø63	Ø80	Ø100
B1 (H 14)		14	16	21	21	25	25
B2 (d 12)		34	40	45	51	65	75
B3 (±0.2)		3.3	4.3	4.3	4.3	4.3	6.3
CN		10	12	16	16	20	20
E	Aluminium	45	52	65	75	95	115
	Steel	45	55	65	75	95	115
H	Aluminium	9	9	11	11	14	14
	Steel	10	10	10	12	14	16
L	Aluminium	13	16	16	21	22	27
	Steel	12	15	17	20	22	25
L1		11.5	12	14	14	16	16
L2 (±0.5)		5.5	5.5	6.5	6.5	10	10
S5		6.6	6.6	9	9	11	11
T		3	4	4	4	4	4
TG		32.5	38	46.5	56.5	72	89
XD		73	77	80	89	100	118
Weight	Aluminium	70	115	200	290	570	820
	Steel	160	270	370	670	1110	2100

Rear male clevis (MP4)

Ordering code	
Aluminium: Ø20-Ø25:	1580.Ø.09/1F
Ø32-Ø100:	1380.Ø.09/1F
Steel: Ø20-Ø25:	1580.Ø.09/2F
Ø32-Ø100:	1320.Ø.21F

The kit comprises:
 n°1 clevis (steel or painted aluminium)
 n°4 screws (plated zinc steel)
 n°1 pin (plated zinc steel) ★
 n°2 circlips (steel)
 ★ (from Ø32)

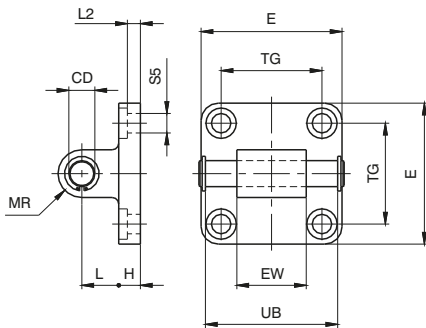
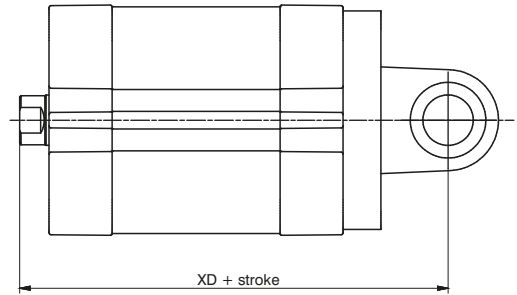

Bore		Ø20	Ø25	Ø32	Ø40	Ø50	Ø63	Ø80	Ø100
CD		8(H9)	8(H9)	10	12	12	16	16	20
E	Aluminium	34	38	45	52	65	75	95	115
	Steel	34	38	45	55	65	75	95	115
EW		16(h14)	16(h14)	26 ^(-0.2/-0.6)	28 ^(-0.2/-0.6)	32 ^(-0.2/-0.6)	40 ^(-0.2/-0.6)	50 ^(-0.2/-0.6)	60 ^(-0.2/-0.6)
H	Aluminium	6	6	9	9	11	11	14	14
	Steel	/	/	10	10	10	12	14	16
L	Aluminium	14	14	13	16	16	21	22	27
	Steel	/	/	12	15	17	20	22	25
MR		8	8	10	12	12	16	16	20
TG		22	26	32,5	38	46,5	56,5	72	89
UB ^(+0.5)		/	/	46	53	61	71	91	111
XD		63	65	73	77	80	89	100	118
L2 (±0.5)		2,6	2,6	5,5	5,5	6,5	6,5	10	10
S5		5,5	5,5	6,6	6,6	9	9	11	11
Weight	Aluminium	25	28	90	130	190	340	580	960
	Steel	70	80	210	330	430	810	1350	2400

Rear male clevis (with jointed head MP6)

Ordering code	
Aluminium:	1380.Ø.15F
Steel:	1320.Ø.25F

The kit comprises:
 n°1 clevis (steel or painted aluminium)
 n°4 screws (plated zinc steel)

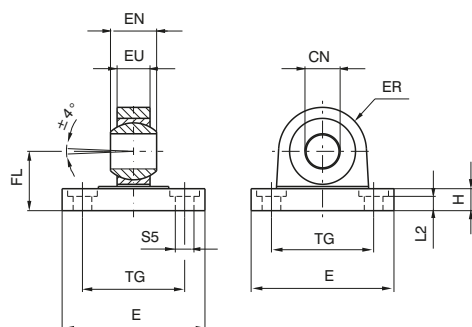
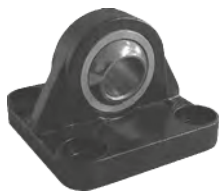
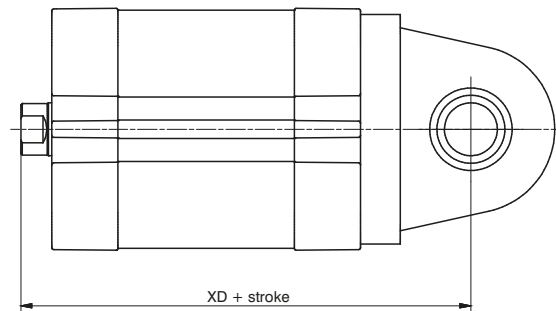

Bore		Ø32	Ø40	Ø50	Ø63	Ø80	Ø100
CN (H 7)		10	12	16	16	20	20
E	Aluminium	45	52	65	75	95	115
	Steel	45	55	65	75	95	115
EN (-0.1)		14	16	21	21	25	25
ER	Aluminium	16	19	21	24	28.5	30
	Steel	15	18	20	23	27	30
EU		10,5	12	15	15	18	18
FL (JS 15)		22	25	27	32	36	41
H	Aluminium	9	9	11	11	14	14
	Steel	10	10	10	12	14	16
L2 (±0.5)		5.5	5.5	6.5	6.5	10	10
S5		6.6	6.6	9	9	11	11
TG		32.5	38	46.5	56.5	72	89
XD		73	77	80	89	100	118
Weight	Aluminium	60	100	180	245	480	650
	Steel	210	310	400	710	1350	2400

Square angle trunnion (AB7)

Ordering code

Aluminium: **1380.Ø.35F**

Steel: **1320.Ø.23F**

The kit comprises:
n°1 clevis (steel or painted aluminium)
n°1 counter clevis, square (steel or painted aluminium)
n°4 screws (plated zinc steel)
n°1 pin (plated zinc steel)
n°2 circlips (steel)

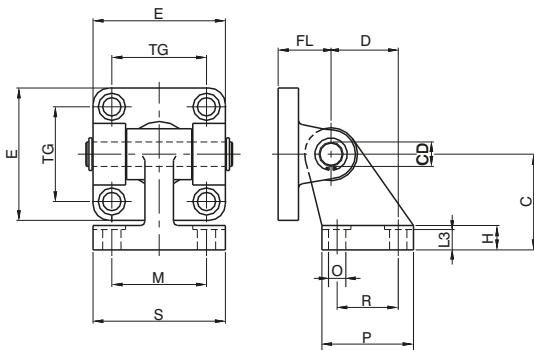
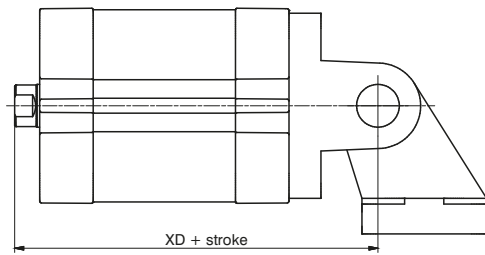

Bore		Ø32	Ø40	Ø50	Ø63	Ø80	Ø100
E	Aluminium	45	52	65	75	95	115
	Steel	45	55	65	75	95	115
TG		32.5	38	46.5	56.5	72	89
FL		22	25	27	32	36	41
D (JS14)		21	24	33	37	47	55
CD		10	12	12	16	16	20
C (JS15)		32	36	45	50	63	71
H	Aluminium	8	10	12	14	14	17
	Steel	8	10	12	12	14	15
L3	Aluminium	6.4	8.4	10.4	12.4	11.5	14.5
	Steel	6.5	8.5	10.5	10.5	11.5	12.5
R (JS14)		18	22	30	35	40	50
P		31	35	45	50	60	70
O (H13)		6.6	6.6	9	9	11	11
S		51	54	65	67	86	96
M (JS14)		38	41	50	52	66	76
XD		73	77	80	89	100	118
Weight g	Aluminium	120	180	225	435	730	1220
	Steel	340	500	640	1250	2100	3500

Square angle trunnion (with joined head)

Ordering code

Steel: **1320.Ø.27F**

The kit comprises:
n°1 clevis (painted steel)
n°1 counter clevis square with joined head (painted steel)
n°4 screws (plated zinc steel)
n°1 pin (plated zinc steel)
n°2 circlips (steel)

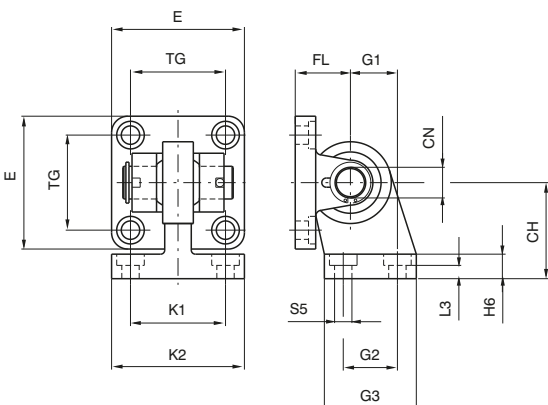
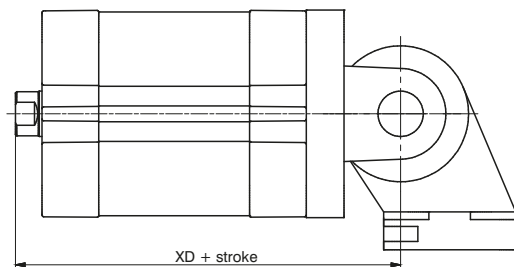

Bore		Ø32	Ø40	Ø50	Ø63	Ø80	Ø100
CH (JS 15)		32	36	45	50	63	71
CN		10	12	16	16	20	20
E		45	55	65	75	95	115
FL (JS 15)		22	25	27	32	36	41
G1 (JS 15)		21	24	33	37	47	55
G2 (JS 14)		18	22	30	35	40	50
G3		31	35	45	50	60	70
H6		10	10	12	12	14	15
K1 (JS 14)		38	41	50	52	66	76
K2		51	54	65	67	86	96
L3 (+0°)		8,5	8,5	10,5	10,5	11,5	12,5
S5		6,6	6,6	9	9	11	11
TG		32,5	38	46,5	56,5	72	89
XD		73	77	80	89	100	118
Weight g		330	480	830	1220	2100	3580

PNEUMATIC ACTUATION

► Square angle trunnion (not specified by ISO-VDMA standard)

Ordering code
Aluminium: **1380.Ø.11F**

The kit comprises:
n°1 clevis (painted aluminium)
n°1 counter clevis square (painted aluminium)
n°4 screws (plated zinc steel)
n°1 pin (plated zinc steel)
n°2 circlips (steel)

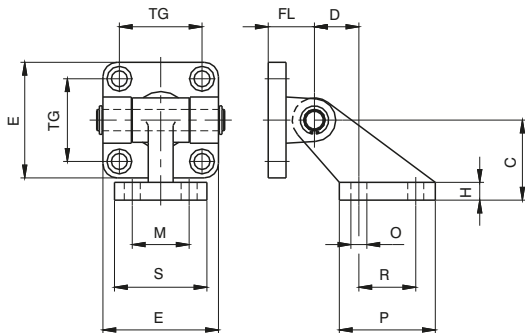
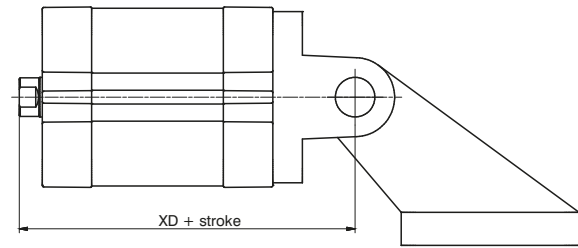

Bore	Ø32	Ø40	Ø50	Ø63	Ø80	Ø100
C (±0,2)	32	45	45	63	63	90
D (±0,5)	18	25	25	32	32	40
E	45	52	65	75	95	115
H	8	10	10	12	12	17
FL	22	25	27	32	36	41
M (JS 14)	25	32	32	40	40	50
TG	32,5	38	46,5	56,5	72	89
O (H 13)	7	9	9	11	11	14
P	37	54	54	75	75	103
R (JS 14)	20	32	32	50	50	70
S	41	52	52	63	63	80
XD	73	77	80	89	100	118
Weight g	130	260	330	600	820	1560

► Square angle trunnion (with joined head)

Ordering code
Aluminium: **1380.Ø.36F**
Steel: **1320.Ø.26F**

The kit comprises :
n°1 clevis (steel or painted aluminium)
n°1 counter clevis with joined head (steel or painted aluminium)
n°4 screws (plated zinc steel)
n°1 pin (plated zinc steel) complete with elastic pin and ring

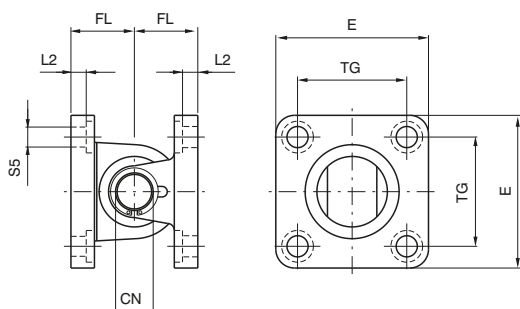
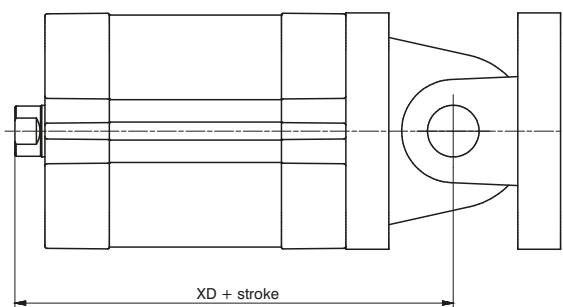

Bore	Ø32	Ø40	Ø50	Ø63	Ø80	Ø100
CN	10	12	16	16	20	20
E	Aluminium	45	52	65	75	95
	Steel	45	55	65	75	95
FL (JS 15)	22	25	27	32	36	41
L2 (±0.5)	5.5	5.5	6.5	6.5	10	10
S5	6.6	6.6	9	9	11	11
TG	32.5	38	46.5	56.5	72	89
XD	73	77	80	89	100	118
Weight g	Aluminium	130	215	380	535	1050
	Steel	380	580	770	1380	2460

Standard trunnion (not specified by ISO-VDMA standard)

Ordering code
Aluminium: 1380.Ø.10F

The kit comprises:
n°1 clevis (painted aluminium)
n°1 counter clevis (painted aluminium)
n°4 screws (plated zinc steel)
n°1 pin (plated zinc steel)
n°2 circlips (steel)

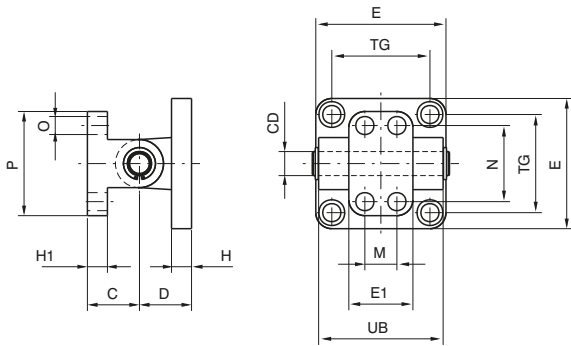
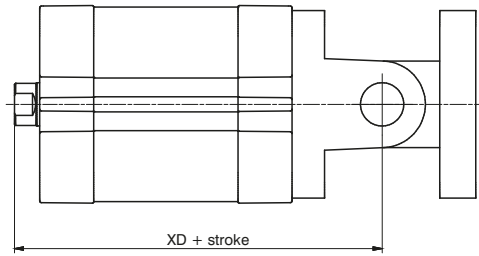

Bore	Ø32	Ø40	Ø50	Ø63	Ø80	Ø100
C (±0,2)	18	26	26	34	34	41
CD	10	12	12	16	16	20
D	22	25	27	32	36	41
E	45	52	65	75	95	115
E1	25	32	32	46	46	56
H	10	10	12	12	16	16
H1	8	10	10	12	12	16
M (±0,2)	-	16	16	25	25	32
N (±0,2)	28	38	38	54	54	90
O	7	9	9	11	11	14
P	40	52	52	75	75	115
TG	32,5	38	46,5	56,5	72	89
UB	45	52	60	70	90	110
XD	73	77	80	89	100	118
Weight g	110	190	240	490	710	1290

Complete standard trunnion

Ordering code
Steel: 1320.Ø.22F

The kit comprises:
n°1 clevis (painted steel)
n°1 counter clevis (painted steel)
n°4 screws (plated zinc steel)
n°1 pin (plated zinc steel)
n°2 circlips (steel)

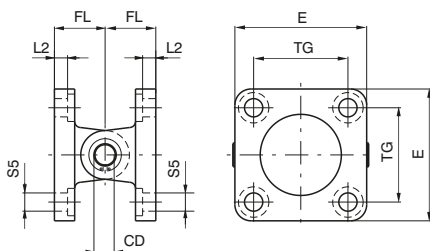
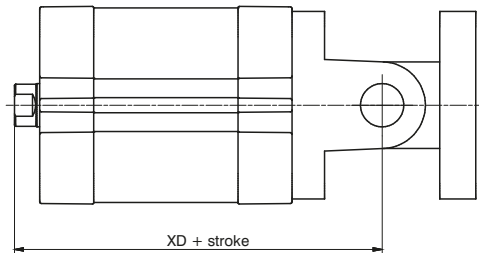

Bore	Ø32	Ø40	Ø50	Ø63	Ø80	Ø100
CD	10	12	12	16	16	20
E	45	55	65	75	95	115
FL	22	25	27	32	36	41
L 2 (±0,5)	5,5	5,5	6,5	6,5	10	10
S 5	6,6	6,6	9	9	11	11
TG	32,5	38	46,5	56,5	72	89
XD	73	77	80	89	100	118
Weight g	360	580	780	1370	2370	4110

Alternative fixing options

Frontal mounting:

- from $\text{Ø}20$ to $\text{Ø}40$ bolt head
- the use of non-magnetic screws is recommended

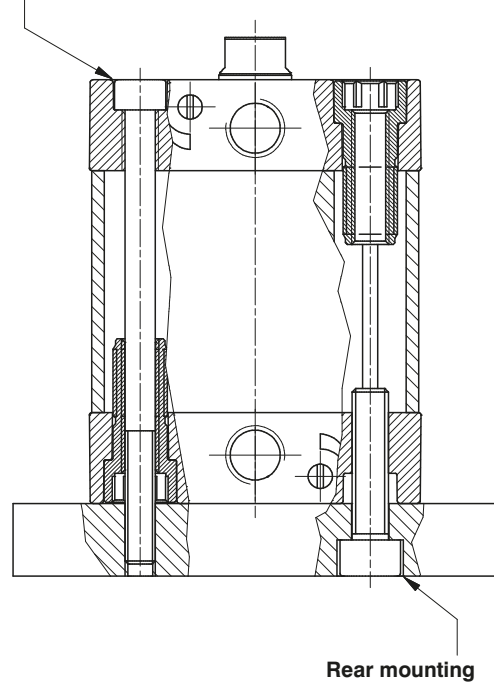

Admissible maximum radial load diagram

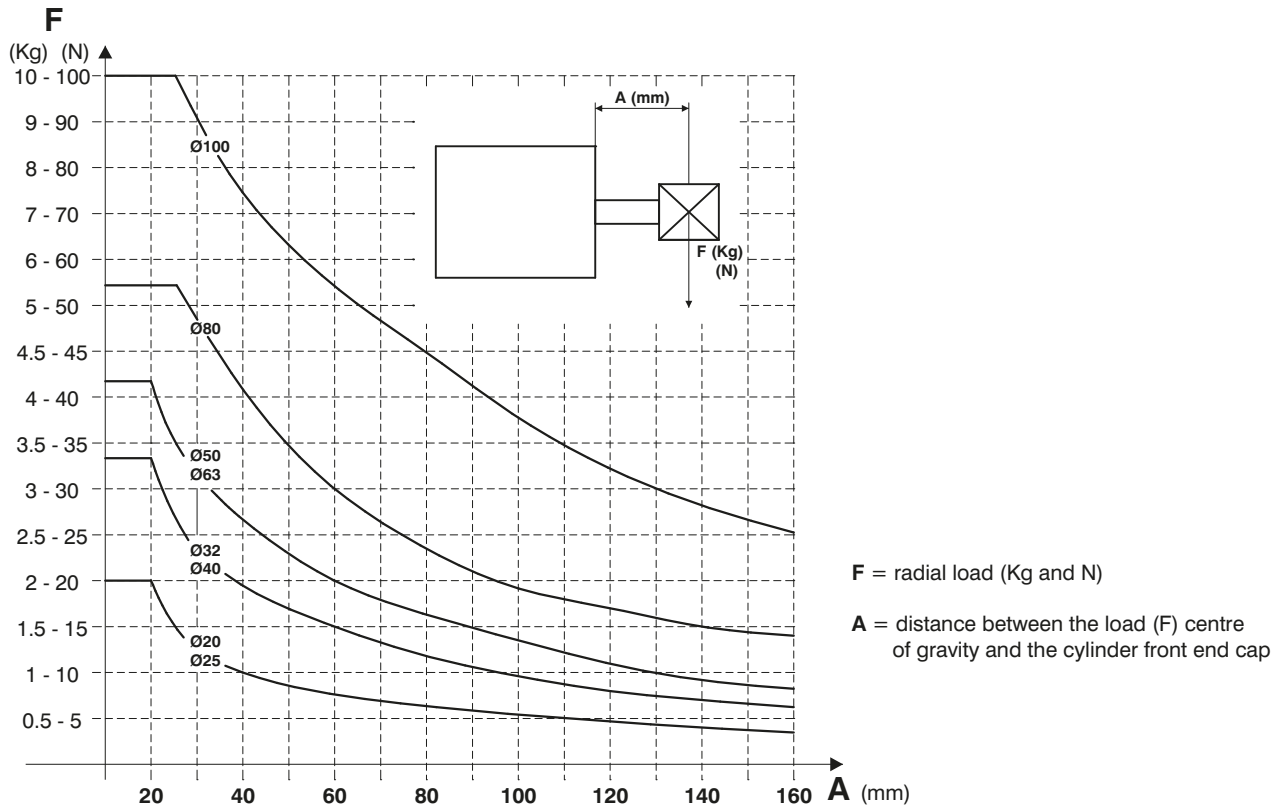

The diagram shows the maximum Radial load F (in Newtons) that can be applied to the cylinder piston rod as a function of the distance A (in mm); based upon the standard version cylinder under static conditions

End of stroke cushioning capacity diagram

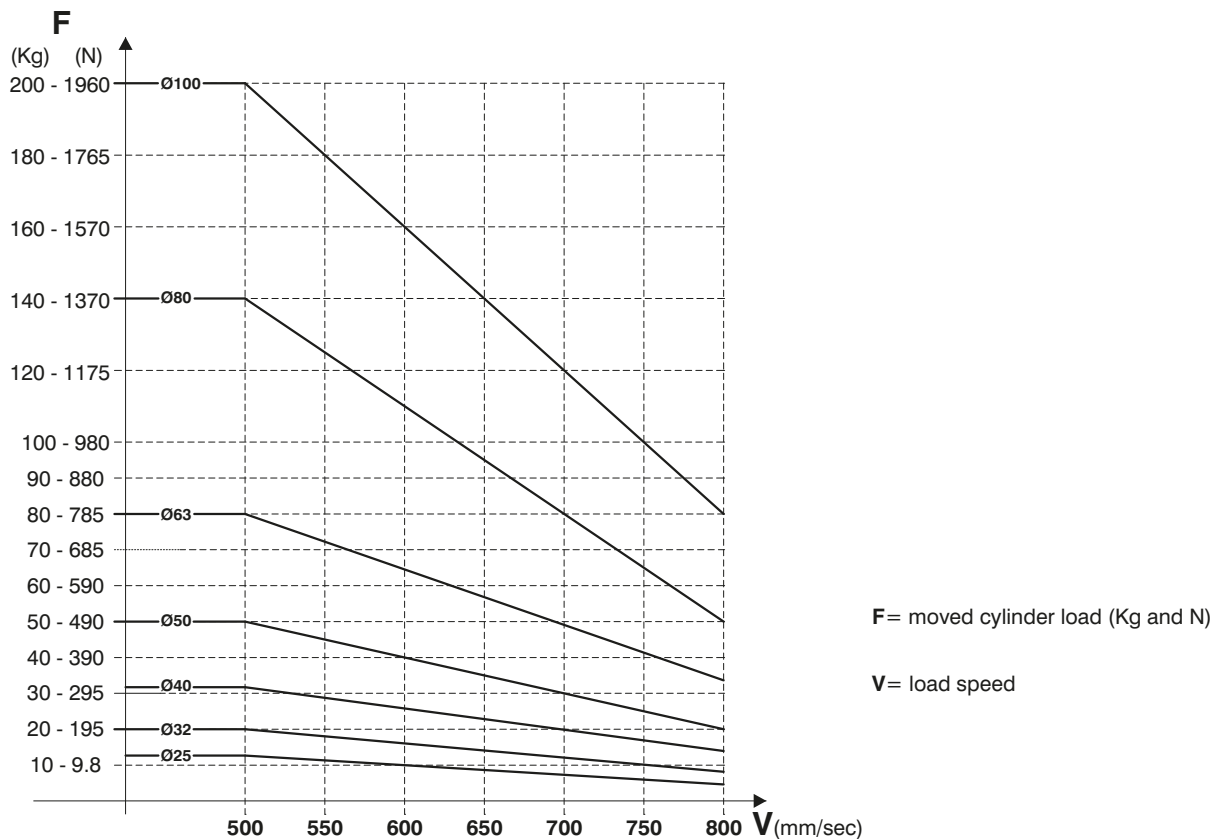

The diagram shows, for each diameter, the safety curves relative to the maximum loads which can be moved by the cylinder in function of its speed V . The data has been calculated under the following test conditions: Cylinder mounted vertically with the rod pointing down, air pressure at 5 bar and with a guided load. Important: Do not exceed the recommended values in the table as reduced life or damage to the cylinder may result.