

Series 1400, Hydraulic speed control cylinders (Ø40 - Ø63)

General

The SKIP and STOP valves are pneumatically actuated 2 ways poppet valves. The SKIP valve (accelerating device) is normally open and is equipped with a supplementary regulator for maximum speed control. It must be activated to obtain speed regulation.

The STOP valve can be normally closed or normally open.

Construction characteristics

| | |
|----------------------|---|
| End caps | black anodised aluminium |
| Barrels | bright painted drawn steel |
| Rod | C43 chromed steel |
| Tie rods | plated zinc steel |
| Piston | aluminium |
| Waterproof seals | NBR rubber |
| Piston seal | FPM |
| Rod seal | PUR |
| Regulators group | brass |
| Skip and stop valves | black anodised aluminium |
| Circuit oil | hydraulic with viscosity 2.9° E at 50°C (viscosity index minimum 118) |
| Bore | 40 mm and 63 mm diameter |

Technical characteristics

| | |
|--|-----------------------------|
| Max connecting load | 600 kg (Ø40) -1200 Kg (Ø63) |
| Min. and max. speed | 60 - 10000 mm/min. |
| Working temperature | -5°C - +70°C |
| Minimum pressure for the actuation of skip and stop valves | 4 bar |

Standard strokes

50 - 100 - 150 - 200 - 250 - 300 - 350 - 400 - 450 - 500 mm
minimum stroke for type 1400.stroke.03.05 and 1400.stroke.03.06, 150 mm.

Important: For heavier load we have available the hydraulic speed control check cylinders of 63 mm diameter suitable to withstand loads up to 1200 kg. For more information please contact our technical department.

Maintenance

The speed control check is a closed system and there are no external factors that can adversely affect its function. Care however, has to be exercised not to allow the hydraulic fluid level to drop below the minimum indicated on the auxiliary tank. Should this occur, cavitation, or worse, an air pocket would result causing erratic control.

Additional fluid should be put in exclusively through a unidirectional valve by means of an appropriate syringe (such as our code number 1400.99.01). Excess fluid will be expelled through a vent into an appropriate container. It is necessary to completely disassemble the regulator and be sure to bleed the system to eliminate air pockets. We suggest that you create a vacuum before beginning to refill.

This can be done with a small unidirectional valve turned up and repeatedly loaded with a syringe.

The rod must be manually actuated successively releasing air through the valve using a small and pointed instrument.

Functional schematics

Outward stroke Control

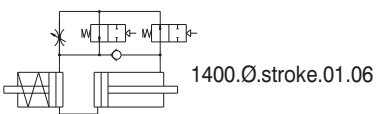
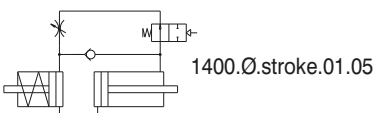
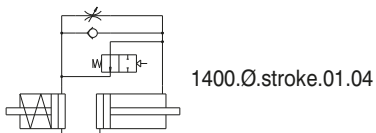
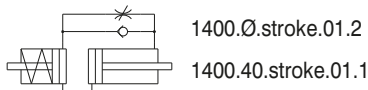

Inward stroke Control

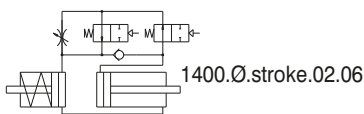
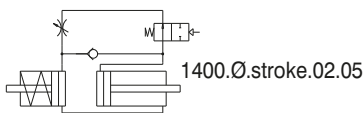
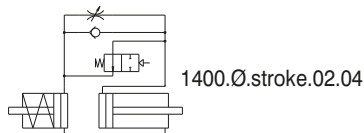
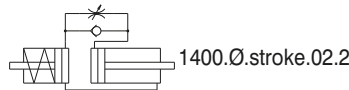

Inward & Outward stroke Control

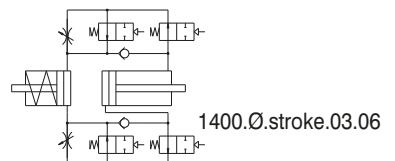
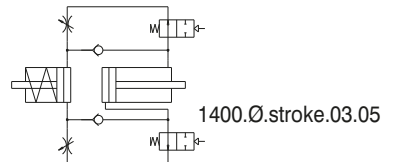
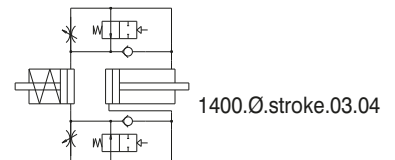
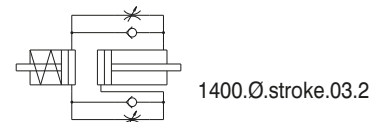

► Regulation on the outward stroke - Tank in line

Ordering code
1400.40.stroke.01.1

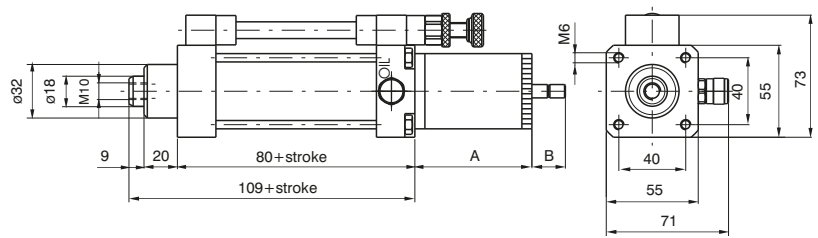

Weight g 1450 + g 300 every 50 mm. stroke

| Strokes | A | B max. |
|------------|-----|--------|
| < 75 | 78 | 30 |
| 75...<150 | 102 | 45 |
| 150...<250 | 127 | 60 |
| 250...<350 | 187 | 90 |
| 350...<500 | 202 | 120 |

► Regulation on the outward stroke – Lateral tank

Ordering code
1400.40.stroke.01.2

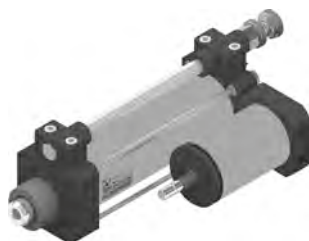
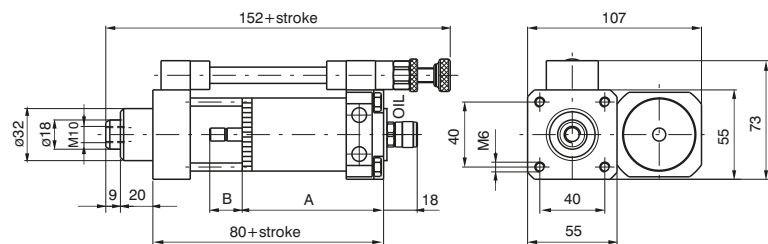

Weight g 1530 + g 300 every 50 mm. di stroke

| Strokes | A | B max. |
|------------|-----|--------|
| < 75 | 93 | 30 |
| 75...<150 | 118 | 45 |
| 150...<250 | 143 | 60 |
| 250...<350 | 183 | 90 |
| 350...<500 | 218 | 120 |

► Regulation on the inward stroke

Ordering code
1400.40.stroke.02.2

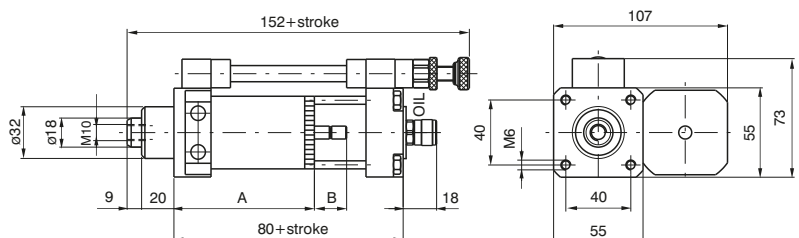

Weight g 1530 + g 300 every 50 mm. di stroke

| Strokes | A | B max. |
|------------|-----|--------|
| < 75 | 93 | 30 |
| 75...<150 | 118 | 45 |
| 150...<250 | 143 | 60 |
| 250...<350 | 183 | 90 |
| 350...<500 | 218 | 120 |

Regulation in both directions

Ordering code

1400.40.stroke.03.2

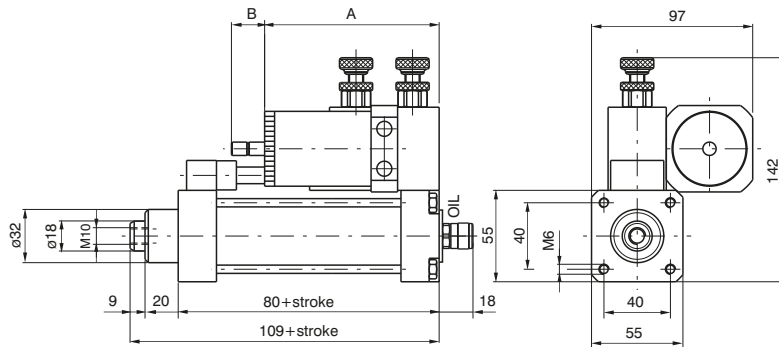

Attention: Minimum stroke=150mm when fitted in tandem (parallel or in-line) with 1319-1320-1321 cylinders series Ø80mm or Ø100mm.

| Strokes | A | B max. |
|------------|-----|--------|
| < 75 | 110 | 30 |
| 75...<150 | 135 | 45 |
| 150...<250 | 160 | 60 |
| 250...<350 | 200 | 90 |
| 350...<500 | 235 | 120 |

Weight g 1870 + g 300 every 50 mm. stroke

Regulation on the outward stroke with skip (Acceleration valve)

Ordering code

1400.40.stroke.01.04

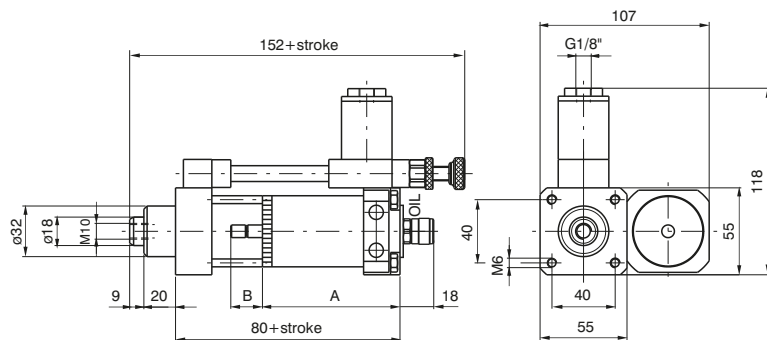

| Strokes | A | B max. |
|------------|-----|--------|
| < 75 | 93 | 30 |
| 75...<150 | 118 | 45 |
| 150...<250 | 143 | 60 |
| 250...<350 | 183 | 90 |
| 350...<500 | 218 | 120 |

Weight g 1670 + g 300 every 50 mm. stroke

Regulation on the outward stroke with stop (Stop valve)

Ordering code

1400.40.stroke.01.05

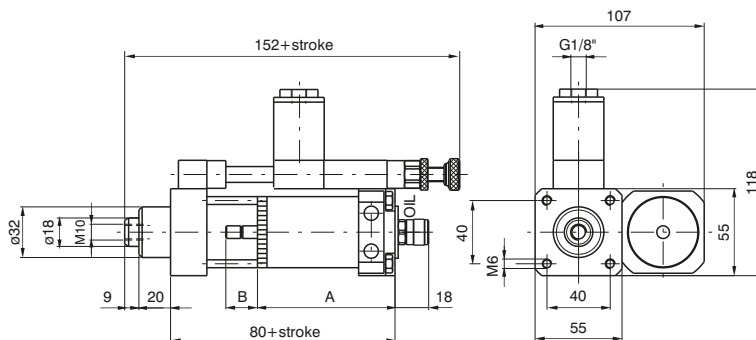

| Strokes | A | B max. |
|------------|-----|--------|
| < 75 | 93 | 30 |
| 75...<150 | 118 | 45 |
| 150...<250 | 143 | 60 |
| 250...<350 | 183 | 90 |
| 350...<500 | 218 | 120 |

Weight g 1710 + g 300 every 50 mm. stroke

3 PNEUMATIC ACTUATION

► Regulation on the outward stroke with skip and stop (Acceleration and stop valves)

Ordering code
1400.40.stroke.01.06

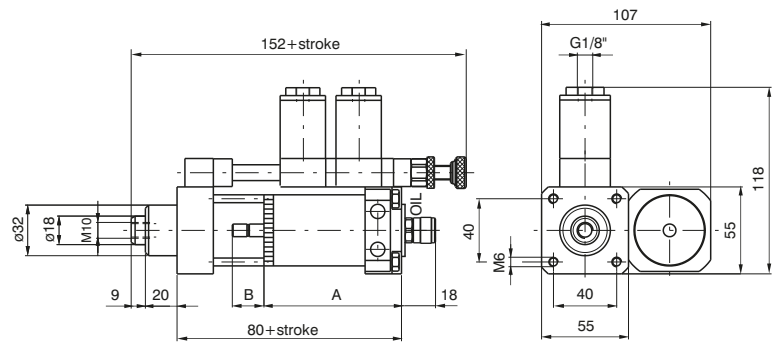

| Strokes | A | B max. |
|------------|-----|--------|
| < 75 | 93 | 30 |
| 75...<150 | 118 | 45 |
| 150...<250 | 143 | 60 |
| 250...<350 | 183 | 90 |
| 350...<500 | 218 | 120 |

Weight g 1830 + g 300 every 50 mm. stroke

► Regulation on the inward stroke with skip (Acceleration valve)

Ordering code
1400.40.stroke.02.04

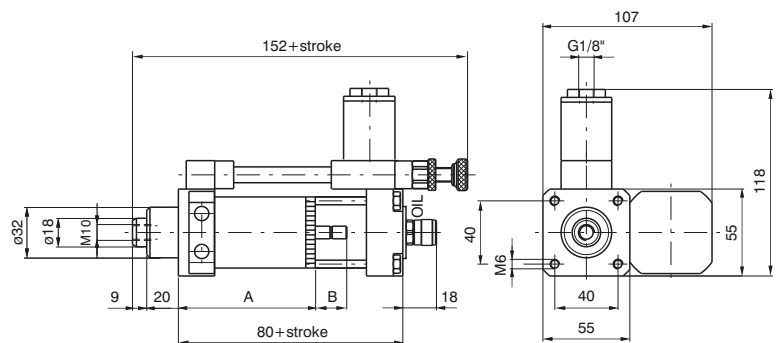

| Strokes | A | B max. |
|------------|-----|--------|
| < 75 | 93 | 30 |
| 75...<150 | 118 | 45 |
| 150...<250 | 143 | 60 |
| 250...<350 | 183 | 90 |
| 350...<500 | 218 | 120 |

Weight g 1670 + g 300 every 50 mm. stroke

► Regulation on the inward stroke with stop (Stop valve)

Ordering code
1400.40.stroke.02.05

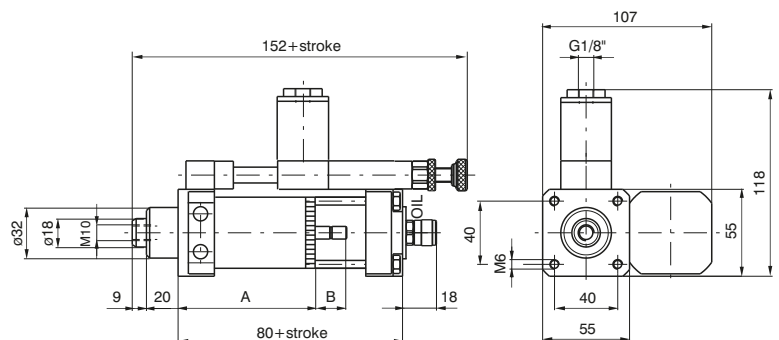

| Strokes | A | B max. |
|------------|-----|--------|
| < 75 | 93 | 30 |
| 75...<150 | 118 | 45 |
| 150...<250 | 143 | 60 |
| 250...<350 | 183 | 90 |
| 350...<500 | 218 | 120 |

Weight g 1710 + g 300 every 50 mm. stroke

► Regulation in both directions with skip and stop (Acceleration and stop valves in both

| |
|-----------------------------|
| Ordering code |
| 1400.40.stroke.03.06 |

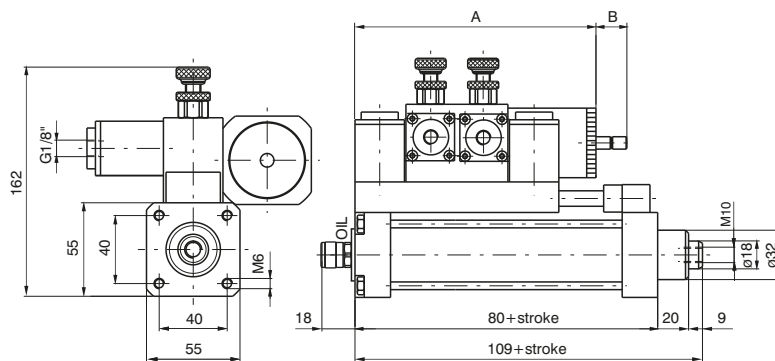

Min. stroke 150 mm
Weight g 2630 + g 300 every 50 mm. stroke

| Strokes | A | B max. |
|---------------|-----|--------|
| 150 ... < 250 | 197 | 60 |
| 250 ... < 350 | 237 | 90 |
| 350 ... < 500 | 272 | 120 |

► Regulation on the outward stroke with skip (Acceleration valve)

Ordering code
1400.63.stroke.01.04

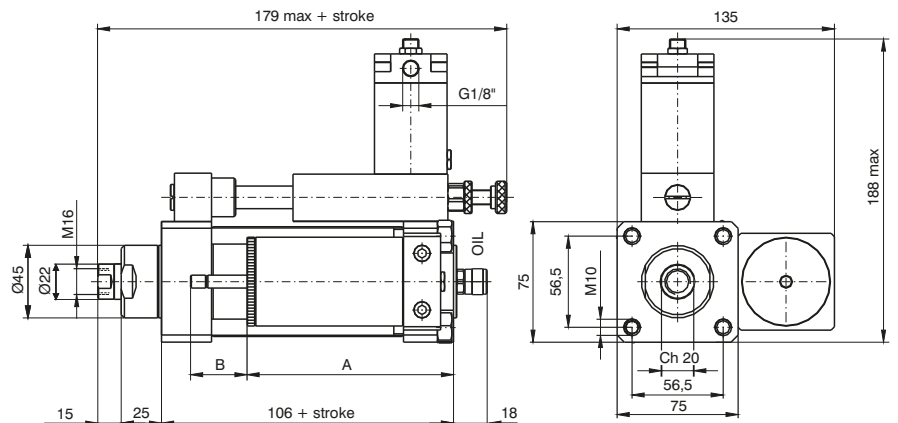

Min. stroke 75 mm
Weight g 3450 + g 850 every 50 mm. stroke

| Strokes | A | B max |
|---------------|-----|-------|
| ≥75 ... <150 | 128 | 50 |
| ≥150 ... <250 | 188 | 80 |
| ≥250 ... <350 | 238 | 100 |
| ≥350 ... <450 | 298 | 130 |
| ≥450 ... ≤600 | 358 | 160 |

► Regulation on the outward stroke with stop (Stop valve)

Ordering code
1400.63.stroke.01.05

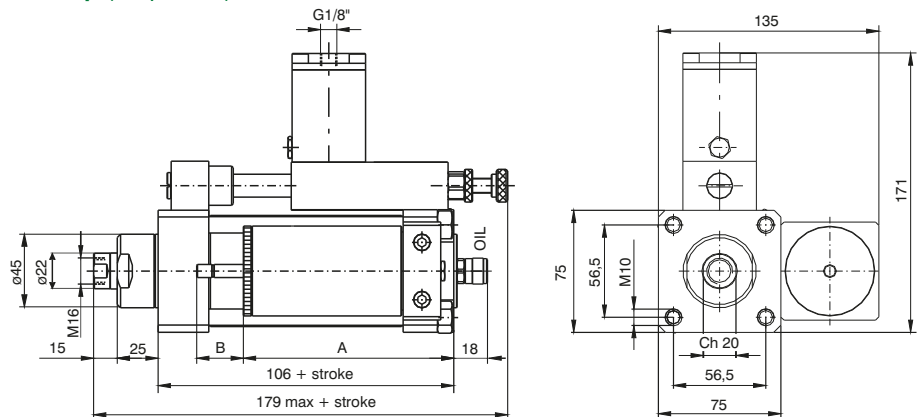
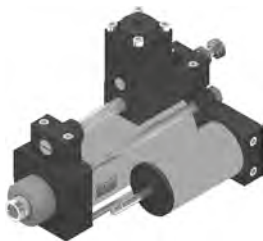

Min. stroke 75 mm
Weight g 3450 + g 850 every 50 mm. stroke

| Strokes | A | B max |
|---------------|-----|-------|
| ≥75 ... <150 | 128 | 50 |
| ≥150 ... <250 | 188 | 80 |
| ≥250 ... <350 | 238 | 100 |
| ≥350 ... <450 | 298 | 130 |
| ≥450 ... ≤600 | 358 | 160 |

► Regulation on the outward stroke with skip and stop (Acceleration and stop valves)

Ordering code
1400.63.stroke.01.06

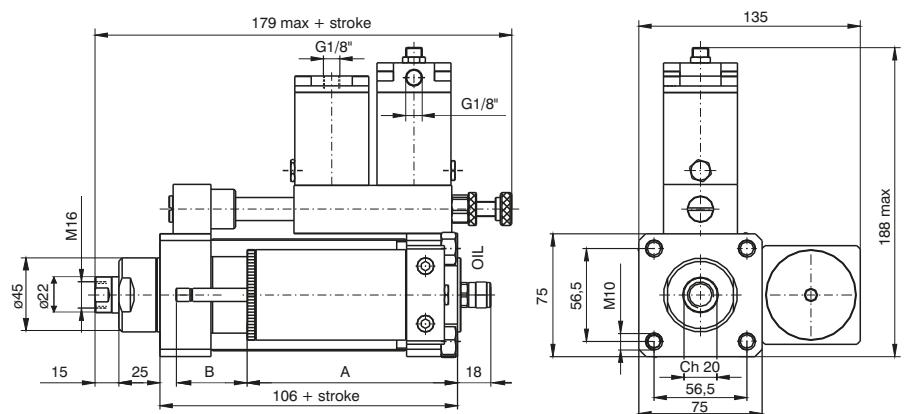
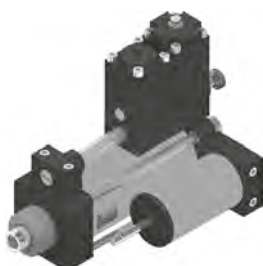

Min. stroke 75 mm
Weight g 3700 + g 850 every 50 mm. stroke

| Strokes | A | B max |
|---------------|-----|-------|
| ≥75 ... <150 | 128 | 50 |
| ≥150 ... <250 | 188 | 80 |
| ≥250 ... <350 | 238 | 100 |
| ≥350 ... <450 | 298 | 130 |
| ≥450 ... ≤600 | 358 | 160 |

Regulation on the inward stroke with skip (Acceleration valve)

Ordering code

1400.63.stroke.02.04

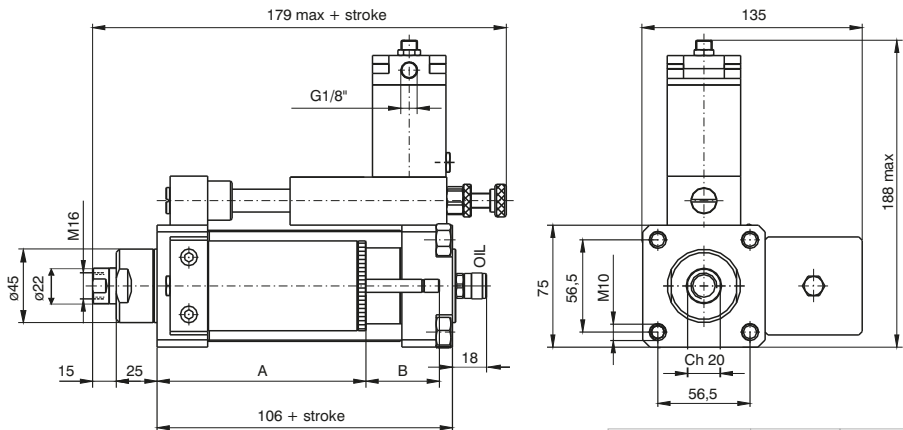

| Strokes | A | B max |
|---------------|-----|-------|
| ≥75 ... <150 | 128 | 50 |
| ≥150 ... <250 | 188 | 80 |
| ≥250 ... <350 | 238 | 100 |
| ≥350 ... <450 | 298 | 130 |
| ≥450 ... ≤600 | 358 | 160 |

Min. stroke 75 mm

Weight g 3450 + g 850 every 50 mm. stroke

Regulation on the inward stroke with stop (Stop valves)

Ordering code

1400.63.stroke.02.05

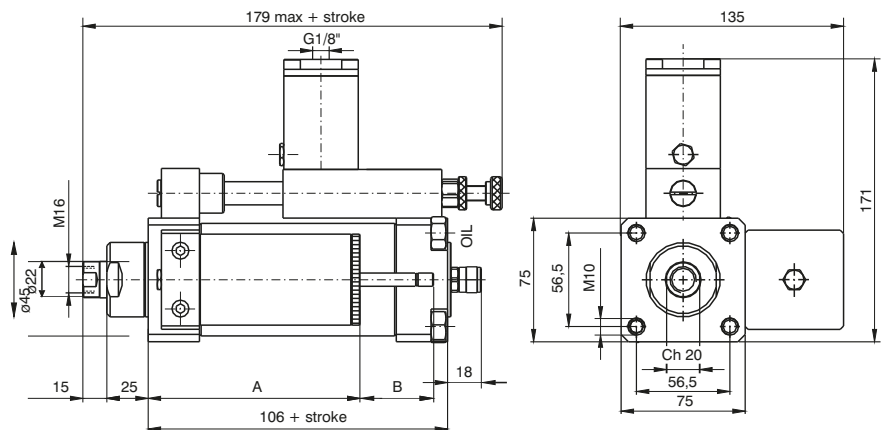
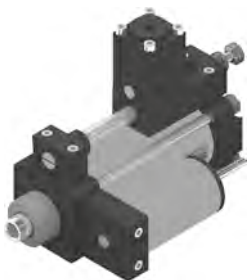

| Strokes | A | B max |
|---------------|-----|-------|
| ≥75 ... <150 | 128 | 50 |
| ≥150 ... <250 | 188 | 80 |
| ≥250 ... <350 | 238 | 100 |
| ≥350 ... <450 | 298 | 130 |
| ≥450 ... ≤600 | 358 | 160 |

Min. stroke 75 mm

Weight g 3450 + g 850 every 50 mm. stroke

Regulation on the inward stroke with skip and stop (Acceleration and stop valve)

Ordering code

1400.63.stroke.02.06

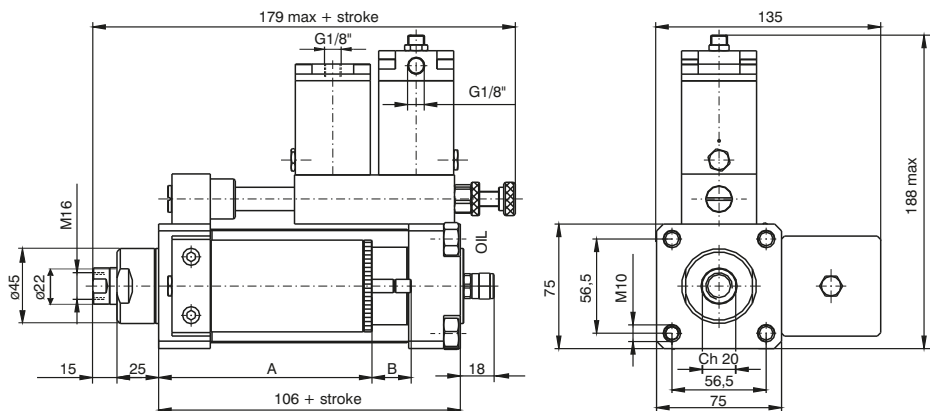
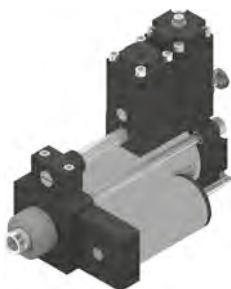

| Strokes | A | B max |
|---------------|-----|-------|
| ≥75 ... <150 | 128 | 50 |
| ≥150 ... <250 | 188 | 80 |
| ≥250 ... <350 | 238 | 100 |
| ≥350 ... <450 | 298 | 130 |
| ≥450 ... ≤600 | 358 | 160 |

Min. stroke 75 mm

Weight g 3700 + g 850 every 50 mm. stroke

► Regulation in both direction with skip (Accelerations valve in two directions)

Ordering code
1400.63.stroke.03.04

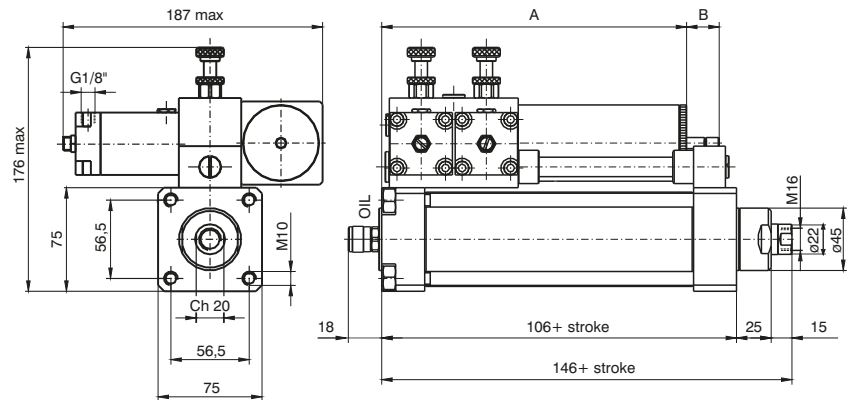
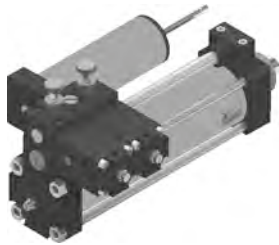

| Strokes | A | B max |
|---------------|-----|-------|
| ≥100 ... <150 | 160 | 50 |
| ≥150 ... <250 | 220 | 80 |
| ≥250 ... <350 | 270 | 100 |
| ≥350 ... <450 | 330 | 130 |
| ≥450 ... ≤600 | 390 | 160 |

Min. stroke 100 mm
Weight g 4100 + g 850 every 50 mm. stroke

► Regulation in both direction with stop (Stop valves in two directions)

Ordering code
1400.63.stroke.03.05

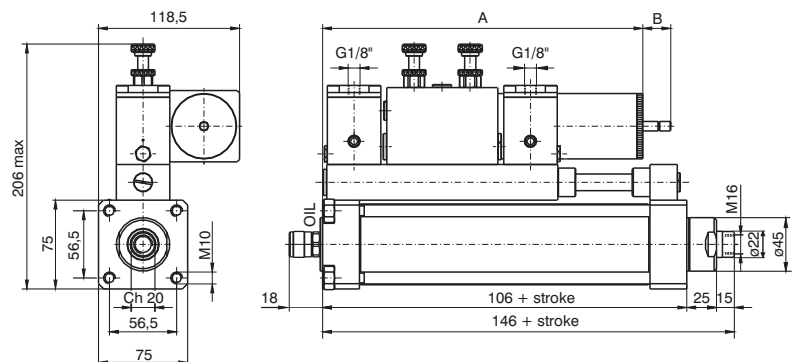
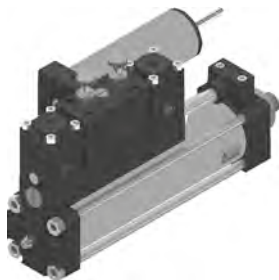

| Strokes | A | B max |
|---------------|-----|-------|
| ≥200 ... <250 | 269 | 80 |
| ≥250 ... <350 | 319 | 100 |
| ≥350 ... <450 | 379 | 130 |
| ≥450 ... ≤600 | 439 | 160 |

Min. stroke 200 mm
Weight g 4850 + g 850 every 50 mm. stroke

► Regulation in both direction with skip and stop (Acceleration and stop valves in two directions)

Ordering code
1400.63.stroke.03.06

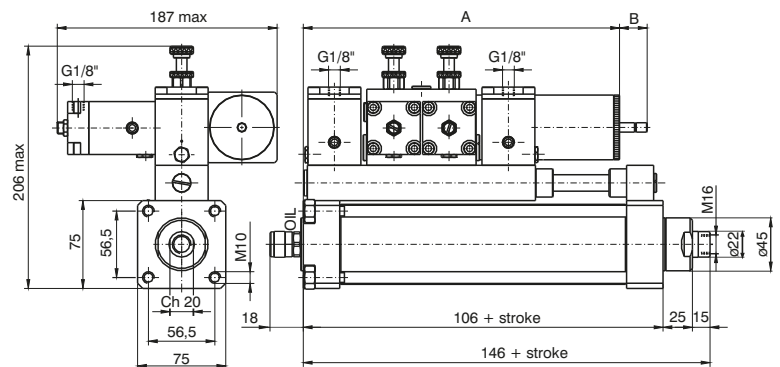
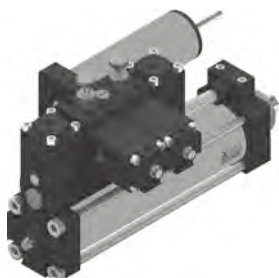

| Strokes | A | B max |
|---------------|-----|-------|
| ≥200 ... <250 | 269 | 80 |
| ≥250 ... <350 | 319 | 100 |
| ≥350 ... <450 | 379 | 130 |
| ≥450 ... ≤600 | 439 | 160 |

Min. stroke 200 mm
Weight g 5400 + g 850 every 50 mm. stroke

Dimensional releases and power supply positions with N.C. stop valves

| Ordering code |
|---|
| 1400.Ø.stroke.01.07 regulation on the outward stroke + stop N.C. |
| 1400.Ø.stroke.01.08 regulation on the outward stroke + skip + stop N.C. |
| 1400.Ø.stroke.02.07 regulation on the inward stroke + stop N.C. |
| 1400.Ø.stroke.02.08 regulation on the inward stroke + skip and stop N.C. |
| 1400.Ø.stroke.03.07 regulation in both directions + stop N.C. |
| 1400.Ø.stroke.03.08 regulation in both directions + skip + stop N.C. |

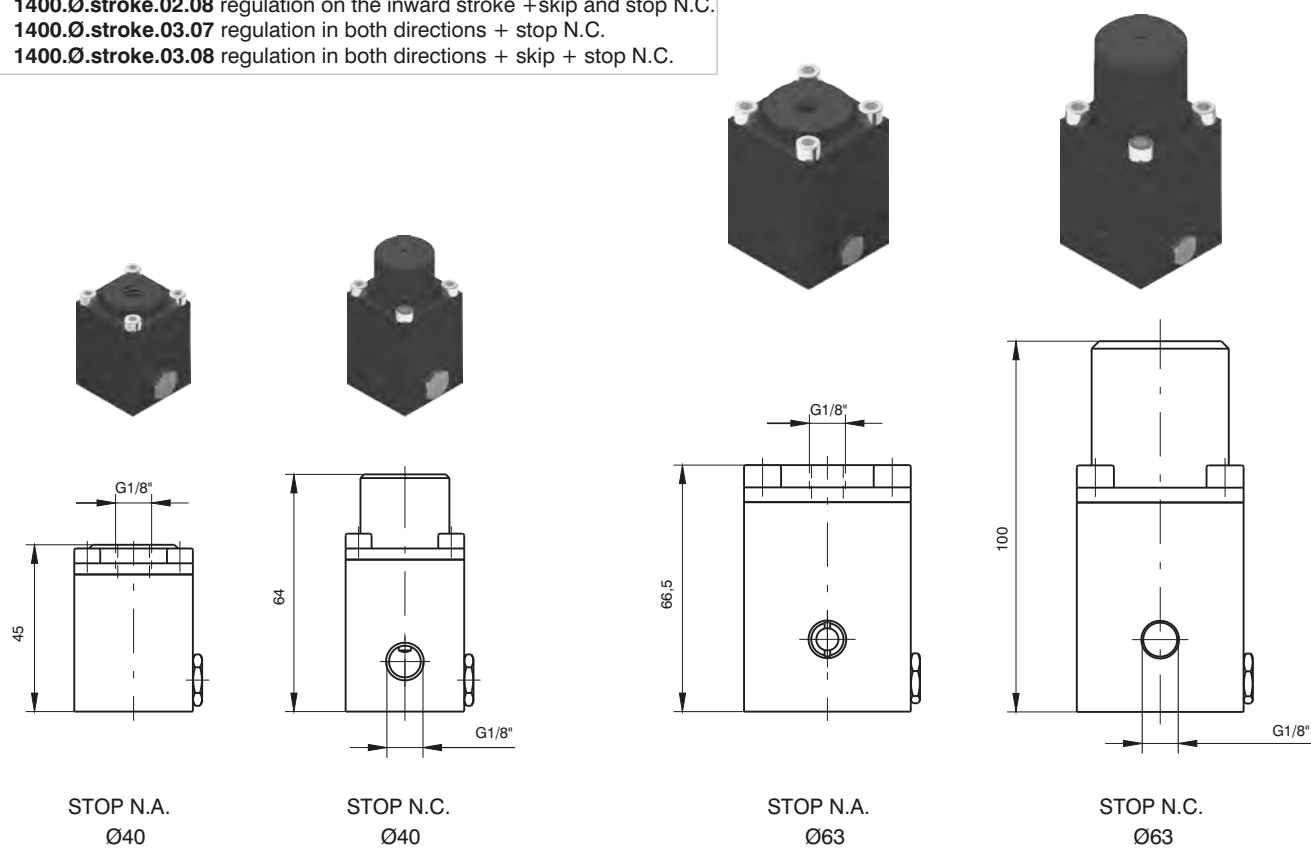

Hydraulic fluid refill syringe

| Ordering code |
|-------------------|
| 1400.99.02 |



Weight g 420

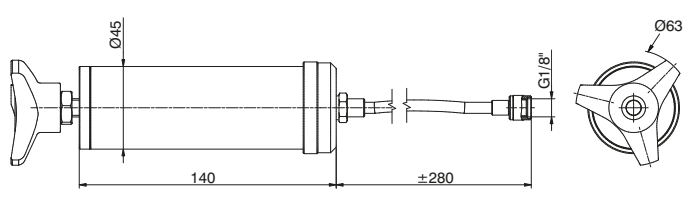

Oil for hydraulic and pneumatic circuits

| Ordering code |
|---|
| PNEUMOIL 01 (1 litre bottles) |



This oil is suitable to lubricate pneumatic circuits and also to refill hydraulic speed control tanks. It is completely compatible with our seals.