

Series 1325-1326-1345-1347, twin rod cylinders

Construction characteristics

Front end cap	anodised aluminium
Rear end cap	UNI 5079 aluminium alloy casting
Rod	C43 chromed steel stainless steel
Barrel	RA=0.3-0.5 anodised aluminium
Cushion bushings	hard aluminium
Piston	vulcanized rubber block on steel core with incorporated permanent magnet, or without magnet for non magnetic version (plus spacer).
Flange	zinc plated steel
Rod seal	PUR
Other seals	NBR 80 shore rubber
Cushioning adjustment screw	nickel-plated steel

Operational characteristics

Fluid	Filtered air. No lubrication needed, if applied it shall be continuous.
Max. pressure	10 bar
Working temperature	-5°C - +70°C

Please follow the suggestions below to ensure a long life for these cylinders:

- use clean and lubricated air
- correct alignment during assembly with regard to the applied load so as to avoid radial components or bending the rod.
- avoid high speeds together with long strokes and heavy loads: this would produce kinetic energy which the cylinder cannot absorb, especially if used as a limit stop (in this case use mechanical stop device)
- evaluate the environmental characteristics of cylinder used (high temperature, hard atmosphere, dust, humidity etc.)

Please note: air must be dried for applications with lower temperature.

Use hydraulic oils H class (ISO VG32) for correct continued lubrication.
Our Technical Department will be glad to help.

Cushioning lengths

Bore	Ø	32	40	50	63	80	100
Front length	mm	22	22	24	32	32	32
Rear length	mm	28	32	32	40	44	50

Standard strokes

- Ø32 25 - 50 - 75 - 100 - 150 - 200 mm
- Ø40 25 - 50 - 75 - 100 - 150 - 200 - 250 mm
- Ø50 25 - 50 - 75 - 100 - 150 - 200 - 250 - 300 mm
- Ø63 25 - 50 - 75 - 100 - 150 - 200 - 250 - 300 - 350 mm
- Ø80 25 - 50 - 75 - 100 - 150 - 200 - 250 - 300 - 350 - 400 - 500 mm
- Ø100 25 - 50 - 75 - 100 - 150 - 200 - 250 - 300 - 350 - 400 - 500 mm

On request are available strokes up to 1000 mm

Stroke tolerance (ISO 15552)

Bore	Stroke	Tolerance
32 - 40 - 50	up to 500 mm	+2
63 - 80 - 100		0

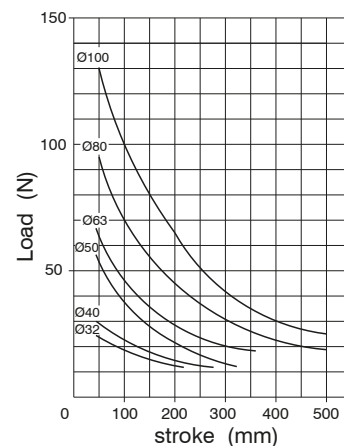
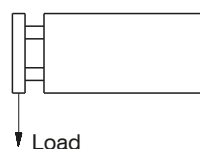

Basic version

Ordering code

- 1325.Ø.stroke.01 magnetic
- 1326.Ø.stroke.01 non magnetic
- 1325.Ø.stroke.01X magnetic stainless steel rod
- 1326.Ø.stroke.01X non magnetic stainless steel rod

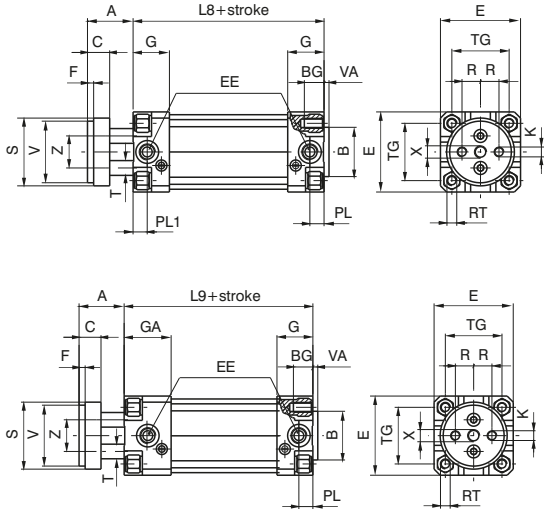

Bore	32	40	50	63	80	100		
A	26	30	37	37	46	51		
AM	22	24	32	32	40	40		
B	30	35	40	45	45	55		
BG	12	12	16	16	20	20		
C	15	15	18	22	22	22		
E	46	52	65	75	95	115		
EE	G 1/8"	G 1/4"	G 1/4"	G 3/8"	G 3/8"	G 1/2"		
F	4	4	5	5	5	5		
G	25	29	29,5	36	36	40		
GA	50	54	54,5	61	61	65		
K	M6	M8	M8	M10	M12	M12		
L8	94	105	106	121	128	138		
L9	119	130	131	146	153	163		
PL	9	11,5	13	14	16	18		
PL1	9,5	11	10,5	14	13	15		
R	9,5	11,25	15	19	25	35		
RT	M6	M6	M8	M8	M10	M10		
S	35	45	55	70	85	105		
T	8	10	12	16	20	20		
TG	32,5	38	46,5	56,5	72	89		
V	32	40	50	63	80	100		
VA	4	4	4	4	4	4		
Z	18	22	26	35	40	50		
WH	26	30	37	37	46	51		
X	M8	M10	M10	M12	M14	M14		
Weight g	Stroke 0 every 10 mm	Basic version	560	810	1380	2300	3680	5740
		Extended ver.	650	950	1500	2500	4100	6300

Extended front cap

- 1345.Ø.stroke.01 magnetic
- 1347.Ø.stroke.01 non magnetic
- 1345.Ø.stroke.01X magnetic stainless steel rod
- 1347.Ø.stroke.01X non magnetic stainless steel rod

Through rod cylinder version with ISO standard

Ordering code

- 1325.Ø.stroke.02 magnetic
- 1326.Ø.stroke.02 non magnetic

Rods options

- 1325.Ø.stroke.02X magnetic stainless steel rod
- 1326.Ø.stroke.02X non magnetic stainless steel rod

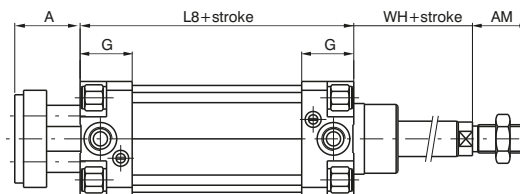

Through rod twin cylinder version

Ordering code

- 1325.Ø.stroke.06 magnetic
- 1326.Ø.stroke.06 non magnetic

Rods options

- 1325.Ø.stroke.06X magnetic stainless steel rod
- 1326.Ø.stroke.06X non magnetic stainless steel rod

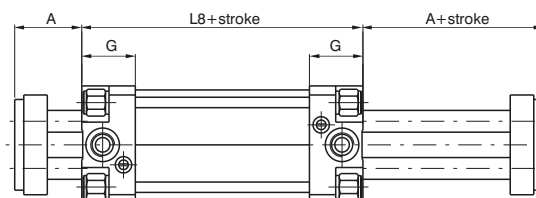

PNEUMATIC ACTUATION

Magnetic sensors

For sensor and sensor support bracket please refer to the 1319 and 1320 series.

Accessories

All of the attachments of the ISO 15552 can be mounted, with the exclusion of the front flange and the foot mounting bracket that, although they are part of the same series, need a small adjustment in the exit zone of the rods. For these there is a different code and the dimensions are indicated below.

Threaded Nipple

Ordering code
1325.Ø.17F

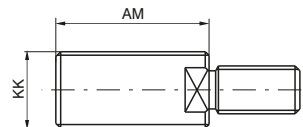

Bore	32	40	50	63	80	100
AM	22	24	32	35	40	40
KK	M10x1,25	M12x1,25	M16x1,5	M16x1,5	M20x1,5	M20x1,5
Weight g	17	27	63	65	110	110

Front Flange

Ordering code
1325.Ø.03F

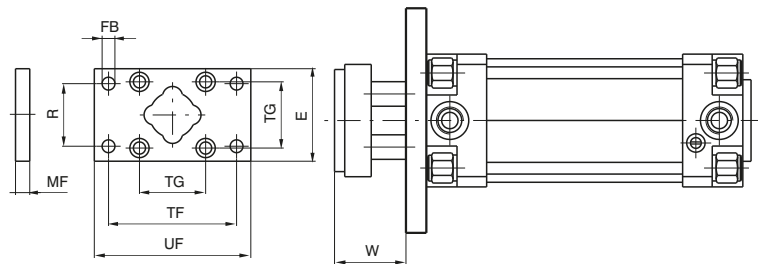

Bore	32	40	50	63	80	100
E	45	52	65	75	95	115
FB (H13)	7	9	9	9	12	14
MF (JS 14)	10	10	12	12	16	16
R (JS 14)	32	36	45	50	63	75
TF (JS 14)	64	72	90	100	126	150
TG	32,5	38	46,5	56,5	72	89
UF	80	90	110	120	150	170
W	16	20	25	25	30	35
Weight g	160	250	480	620	1430	3500

Front foot mounting bracket (short)

Ordering code
1325.Ø.05/1F (1 piece)

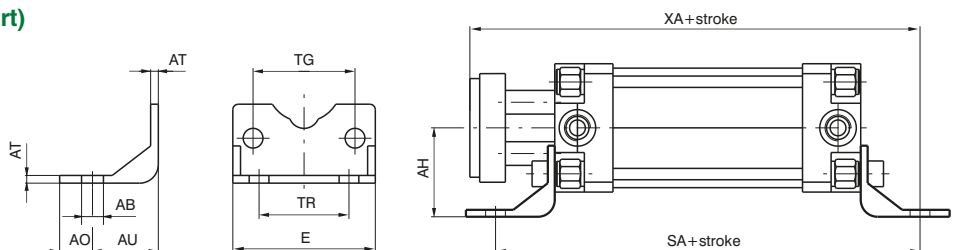

Bore	32	40	50	63	80	100
AB (H14)	7	9	9	9	12	14
AH (JS 15)	32	36	45	50	63	71
AO (± 0,2)	11	8	13	13	14	15
AT	3,5	3,5	3,5	4,5	5	5
AU	24	28	32	32	41	41
E	45	52	65	75	95	115
SA	142	161	170	185	210	220
TG	32,5	38	46,5	56,5	72	89
TR (JS 14)	32	36	45	50	63	75
XA	144	163	175	190	215	230
Weight g	50	70	120	180	320	400