

► Vane type rotary actuators



**General**

The vane type rotary actuators, 6420 series is designed to operate at 90-180 or 270 deg. In a contained space. Dimensionally are more compact than other types of rotary actuators.

The range includes bore sizes from 10 to 100 in 4 configurations:

- basic.
- with rotary angle adjustment mechanism.
- with sensing support.
- with rotary angle adjustment mechanism and sensing support.

The bodies are in aluminium, the shafts in chrome plated steel and the seals in NBR.

The sensing support kit enables for the sensors to be positioned in any position.

The rotary angle adjustment mechanism enables the adjustment of the complete rotation on bore sizes 10 to 40 while on the others sizes carries as standard hydraulic dampers which enable the adjustment only of the last part of the rotation.

The units can be fixed using the thread on the body or the through holes on the body.

On bore sizes 50 to 100 the shaft runs into ball bearings which ensure high resistance. o rotante è guidato su cuscinetti a sfere che assorbono i carichi radiali e assiali, garantendo durata e affidabilità. assiali, garantendo durata e affidabilità.

**Ordering code**

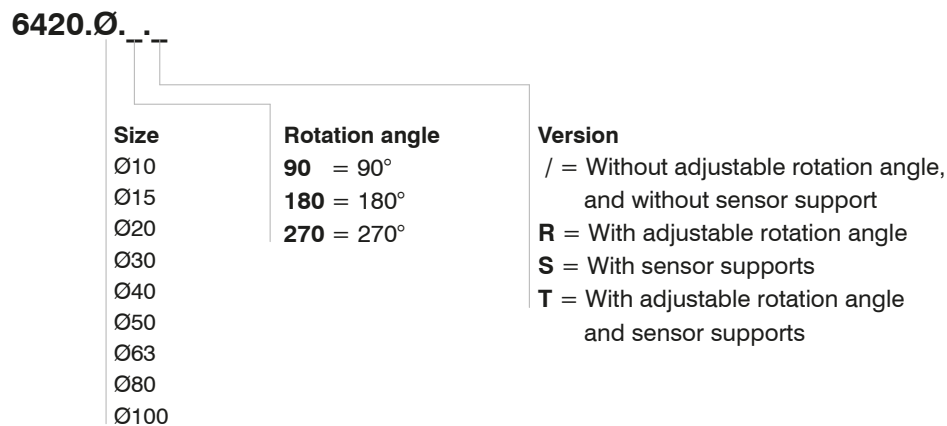

**Construction characteristics**

Body	anodised aluminium
Rod	steel
Seals	NBR
Vane	vulcanized NBR rubber on steel core
Cushoning	elastic bumper; hydraulic dampers from size Ø50 - Ø100 versions R or T

**Operational characteristics**

Fluid	Filtered air. No lubrication needed, if applied it shall be continuous.
Working pressure	1,5 - 7 bar
Temperature	0°C - 50°C
Rotation range	90° - 180° - 270°
Max. allowed leak	Ø10 - Ø40 = 0,3 NI/min / Ø50 - Ø100 = 0,5 NI/min

Overall dimensions Ø10 - Ø40

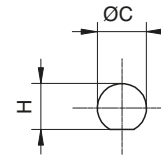
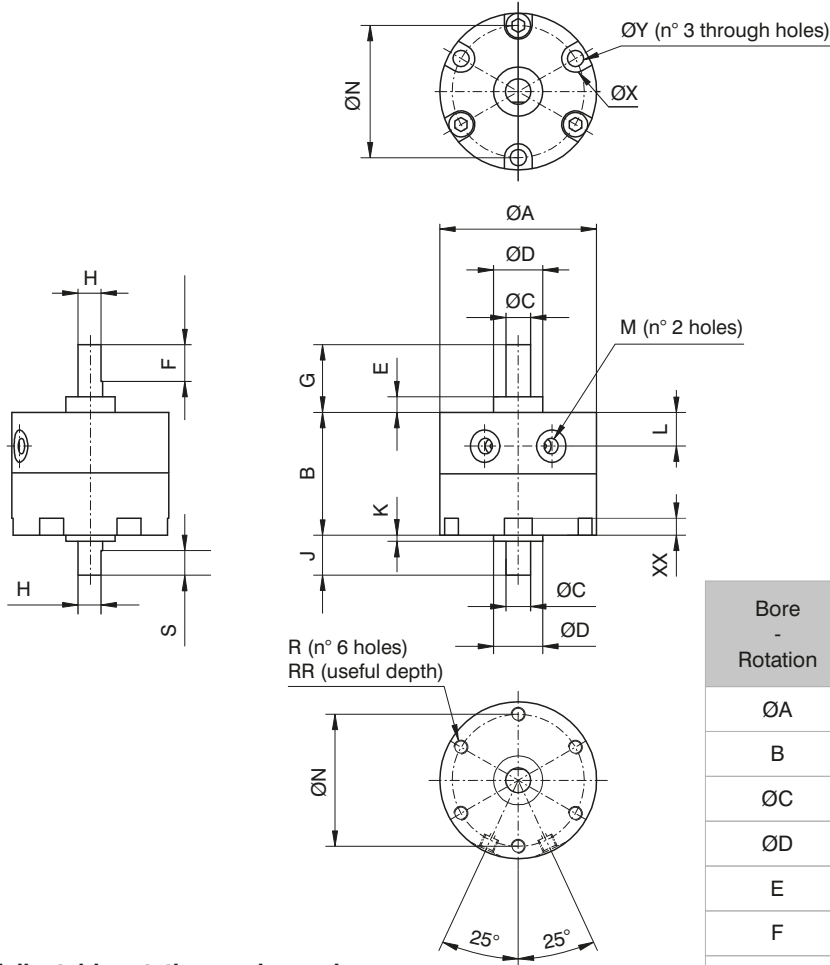

- Ø10 - Ø30 long shaft  
- Ø10 - Ø40 short shaft

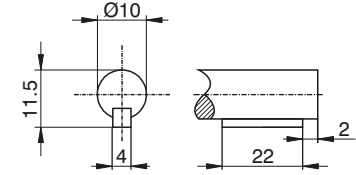

- Ø40 long shaft

Adjustable rotation angle version

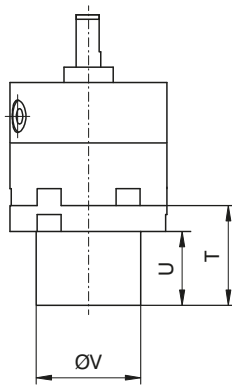

With sensor support version

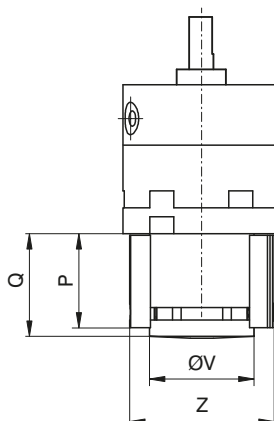

Bore - Rotation	10 - 90°	15 - 90°	20 - 90°	30 - 90°	40 - 90°	
	10 - 180°	15 - 180°	20 - 180°	30 - 180°	40 - 180°	
	10 - 270°	15 - 270°	20 - 270°	30 - 270°	40 - 270°	
ØA	30	35	44	51	64	
B	17	20,1	29,1	40	45	
ØC	4	5	6	8	10	
ØD	9	12	14	16	25	
E	3	4	4,5	5	6,5	
F	9	10	10	12	22	
G	14	18	20,3	22	30	
H	3,5	4,5	5,5	7,5	9	
J	8	9	9,6	13	15	
K	1	1,5	1,6	2	4,5	
L	4,2	5	8,5	11	9,5	
M	M5x0,8	M5x0,8	M5x0,8	M5x0,8	M5x0,8	
ØN	24	29	36	43	56	
P	23,3	28	28	30,8	33	
Q	24	29,5	30,5	34	36	
R	M3x0,5	M3x0,5	M4x0,7	M5x0,8	M5x0,8	
RR	3	3	4,5	9	9	
S	5	6	7	8	9	
T	24	28	28,5	32,5	34,5	
U	18	22	21	24	26	
ØV	18	24	30	34	34	
ØX	6	6	7,5	9	9	
XX	3,5	3,5	4,5	5,5	5,5	
ØY	2,3	2,3	3,2	4,2	4,2	
Z	29	34	42	47	47	
Weight (g)	Base	28	48	112	200	342
	With regulation rotation system	78	116	240	390	805

Overall dimensions Ø50 - Ø100

R (n° 6 threads on both sides)  
RR (useful depth)      ØVA (n° 4 holes)

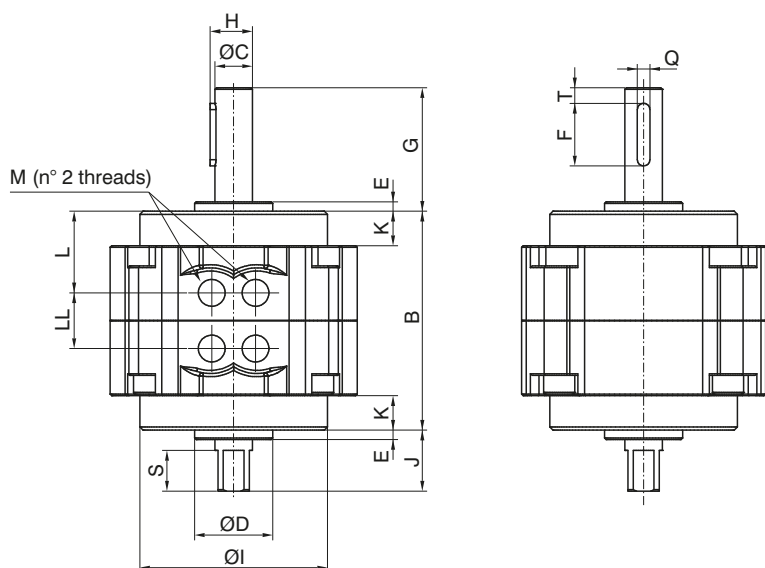
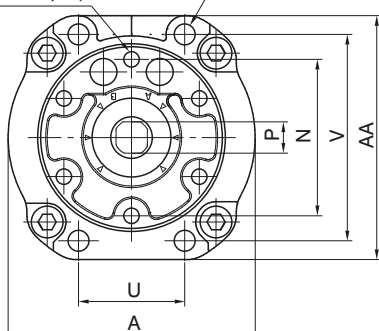

Adjustable rotation angle version

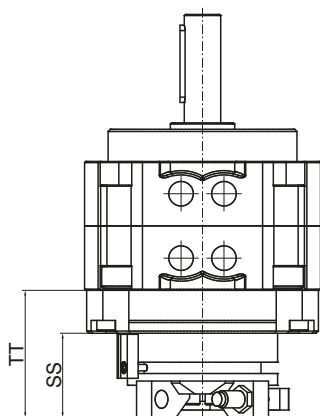

With sensor support version

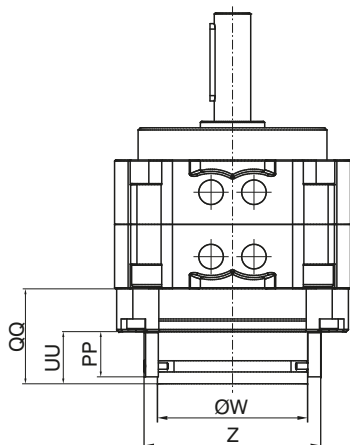

Bore - Rotation	50 - 90°	63 - 90°	80 - 90°	100 - 90°
	50 - 180°	63 - 180°	80 - 180°	100 - 180°
	50 - 270°	63 - 270°	80 - 270°	100 - 270°
A	79	98	110	140
AA	78	98	110	140
B	70	80	90	103
ØC	12	15	17	25
ØD	25	28	30	45
E	3	3	3	4
F	20	25	36	40
G	39,5	45	53,5	65
H	13,5	17	19	29
ØI	60	75	88	108
J	19,5	21	23,5	30
K	11	14	15	11,5
L	26	28,9	30	35,4
LL	18	22,2	30	32,2
M	G1/8"	G1/8"	G1/4"	G1/4"
N	50	60	70	80
P	10	12	13	19
PP	21	21	21	21
Q	4	5	5	7
QQ	39,4	43	44	48,5
R	M6x1	M8x1,25	M8x1,25	M10x1,5
RR	8	10	14	14
S	13	14	16	16
SS	38	38	39	39,5
T	5	7,5	5	5
TT	53	56,5	59	63
U	34	39	48	60
UU	24,5	24,5	24,5	24,5
V	66	83	94	120
ØVA	6,5	9	9	11
ØW	60	60	70	70
Z	73	73	83	83
Weight (g)	Base	760	1290	4100
	With regulation rotation system	1100	1690	2370

3 PNEUMATIC ACTUATION

Key flat position and adjustable rotation angle Ø10 - Ø40

ROTATING SHAFT KEY FLAT POSITION

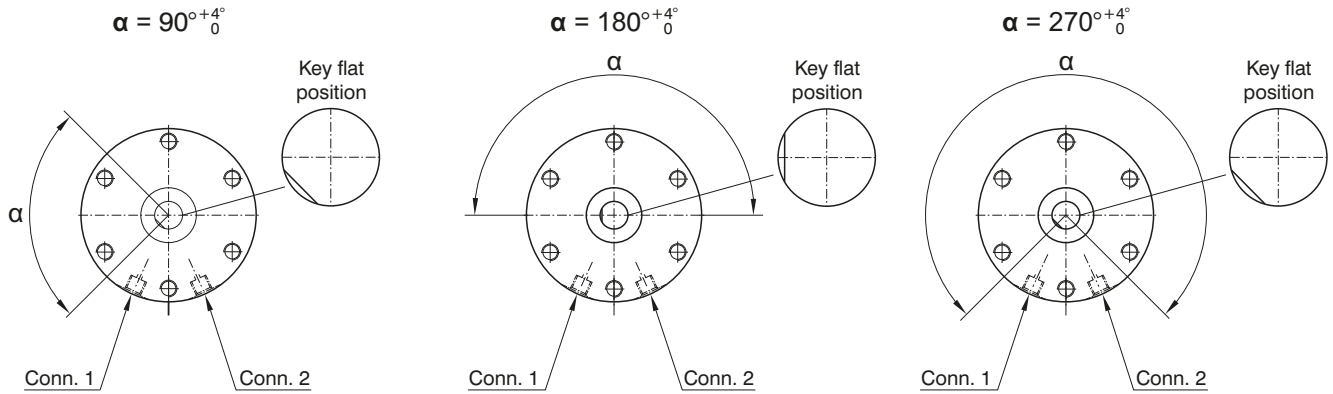

ROTATION ANGLE SETUP

To regulate the rotation angle (codes 6420..R or T), follow the instructions below

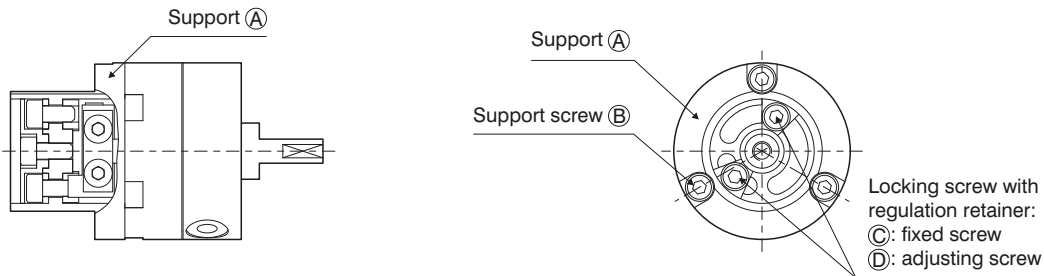

Phase 1 : Choose the regulation configuration based on the following options  
(consider the actuator base position):

rotation 90°, regulation 0 - 90°, rotation 180°, regulation 0 - 180°, rotation 270°, regulation 0 - 175°

ROTATION CONFIGURATION

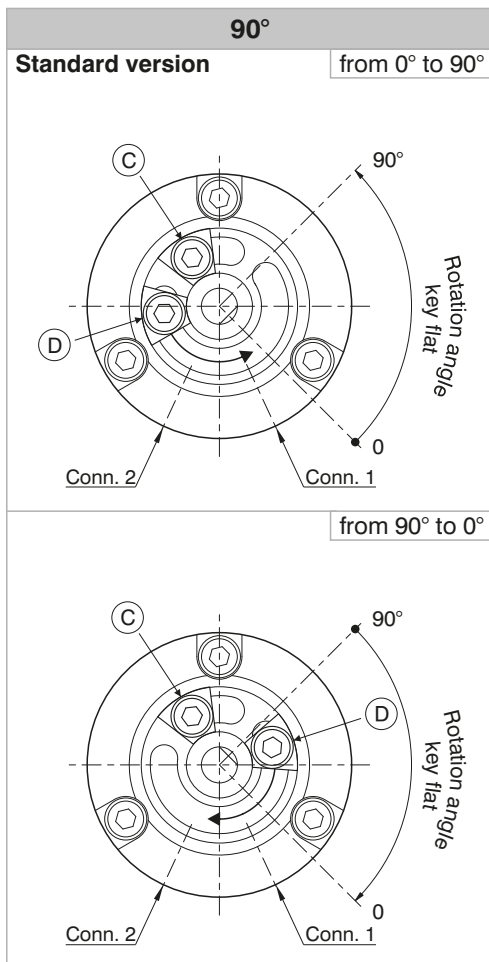

ROTATION CONFIGURATION

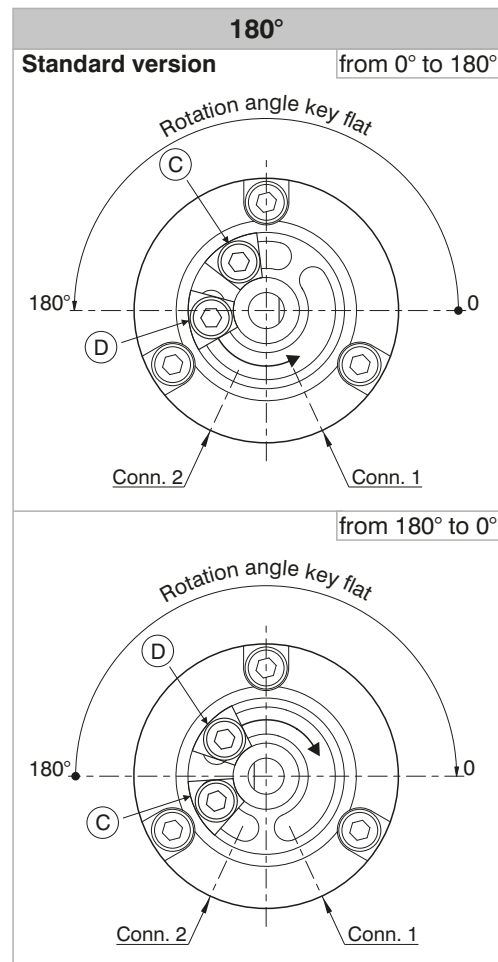

3 PNEUMATIC ACTUATION

Key flat position and adjustable rotation angle Ø10 - Ø40

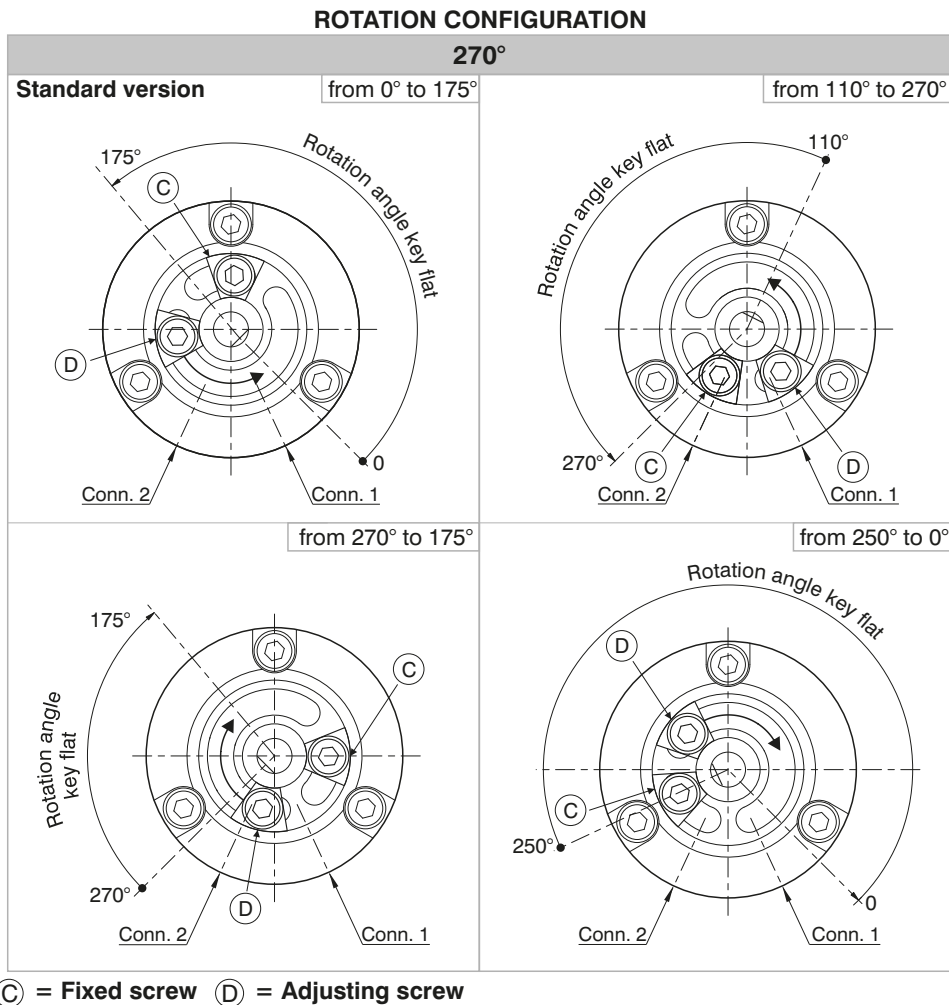

**Phase 2 :** If the desired settings do not correspond to the basic version settings:

- remove screw (E) and disk (F) or (G) (depending on the version) (see figure 1)
- remove screws (B), the actuator support (A) (see figure 1) and unlock blocking screws (C) and (D) (see rotation configuration)
- position screws (C) and (D) and the key flat of rotating shaft as indicated in the chosen rotation configuration in order to align the key flat of rotating shaft (see figure 2)
- re-assemble actuator support (A), tighten screws (B)
- position screws (C) and (D) according to the desired adjustment and tighten the screws
- re-assemble disk (F) or (G) and screw (E)

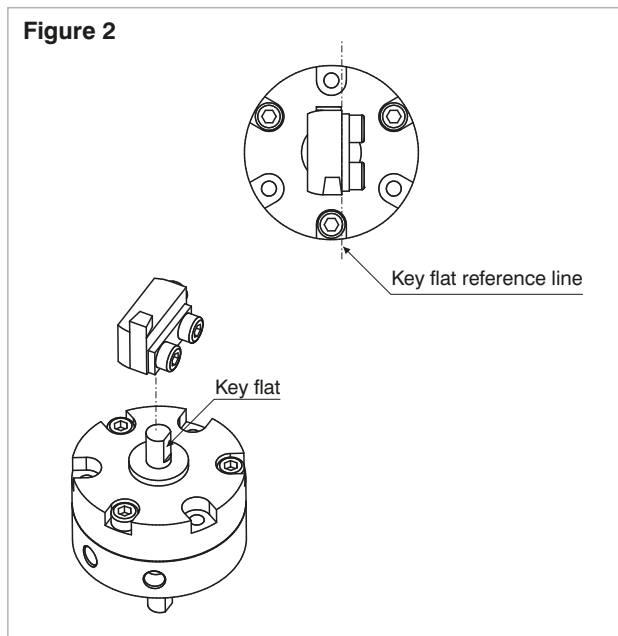
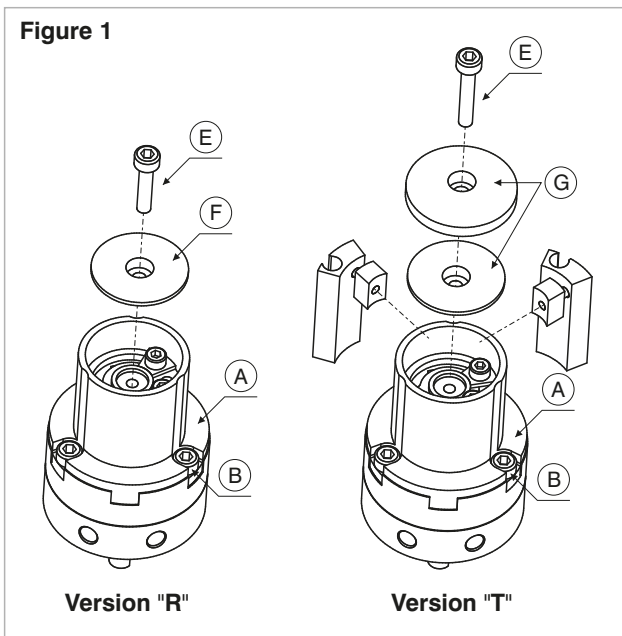

### Spline position and adjustable rotation angle Ø50-Ø100

#### ROTATING SHAFT SPLINE POSITION

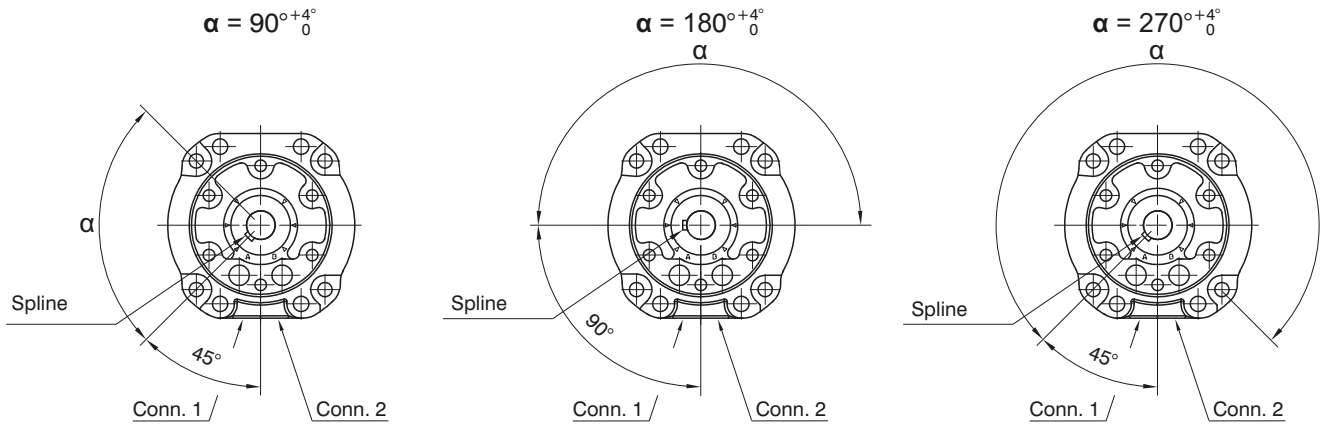

#### ROTATION ANGLE SETUP

The version with adjustable rotation angle (cod. 6420..R or T) is available with hydraulic dampers which enable to regulate the rotation angle by 15° and to decelerate moving mass.

Example: for 90° rotation and 15° regulation per decelerator, the effective rotation angle is 60°

Example: for 180° rotation and 15° regulation per decelerator, the effective rotation angle is 150°

Example: for 270° rotation and 15° regulation per decelerator, the effective rotation angle is 240°

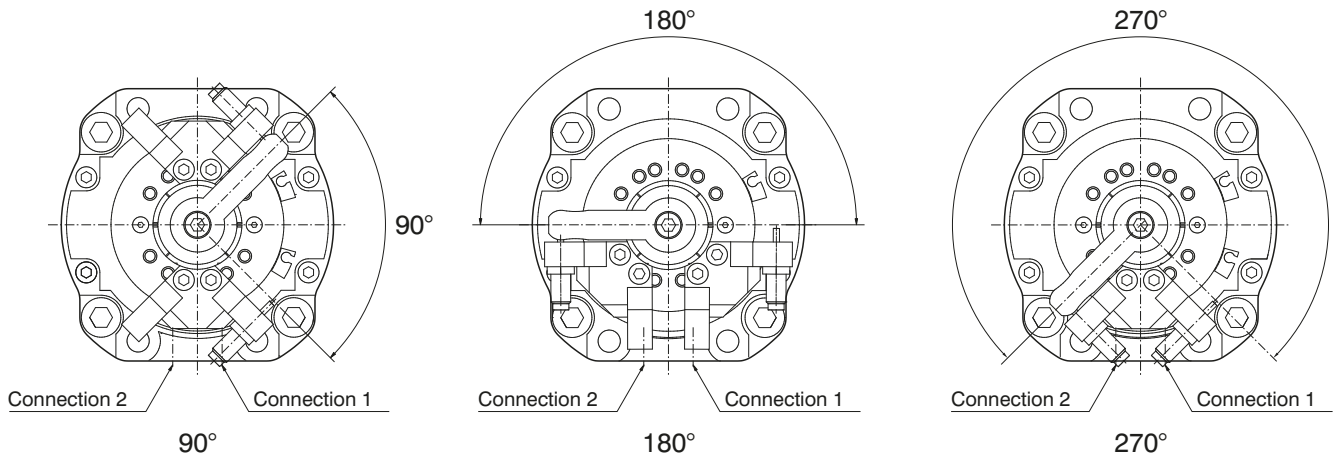

**Switch positioning instructions Ø10 - Ø40**

- Phase 1** - Unfasten screw (A)
- Phase 2** - Assemble the switch (C) into the dedicated housing (B) and lock with screw (D)
- Phase 3** - Rotate block (B) in the desired position (see following image)

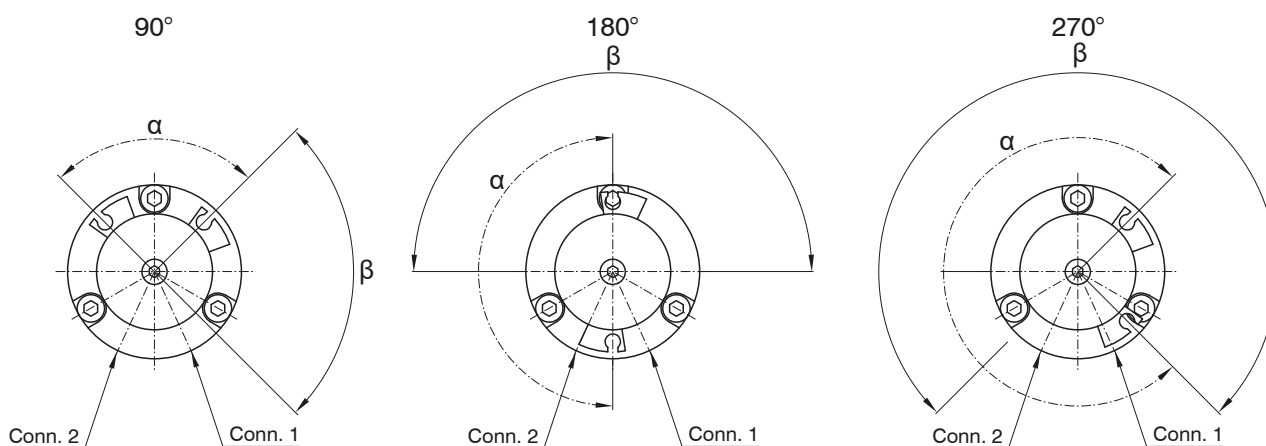
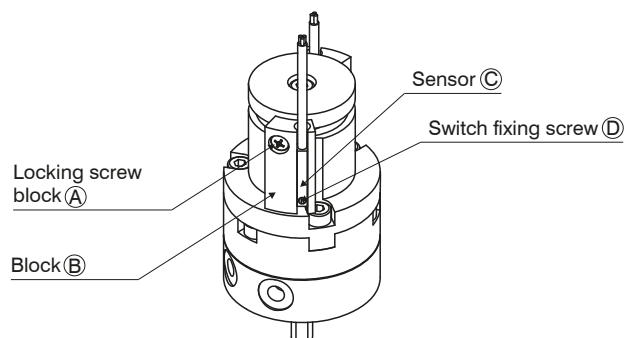

**α** - magnet rotating angle  
**β** - shaft key flat rotating angle  
 For correct functionality position the switch within angle **α**

- Phase 4** - tighten screw (A)
- Phase 5** - repeat the following phases for the second switch

**AVAILABLE SENSORS**

	Code
	1581.U
	TRS.U
	1581.HAP
	THS.P

	Code
	1583.DC
	1583.HAP
	THR.P

3 PNEUMATIC ACTUATION

### Switch positioning instructions Ø50 - Ø100

**Phase 1** - Unfasten screw (A)

**Phase 2** - Assemble the switch (C) into the dedicated housing (B) and lock with screw (D)

**Phase 3** - Rotate block (B) in the desired position (see following image)

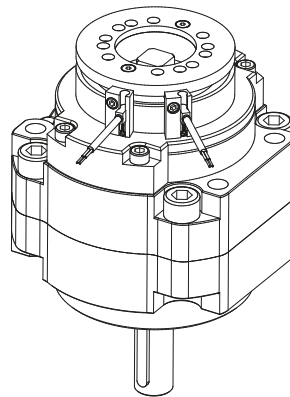
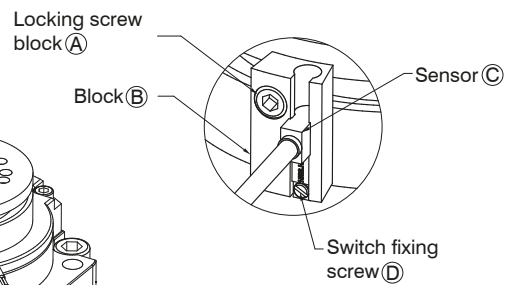

90°

180°  
 $\alpha$

270°  
 $\alpha$

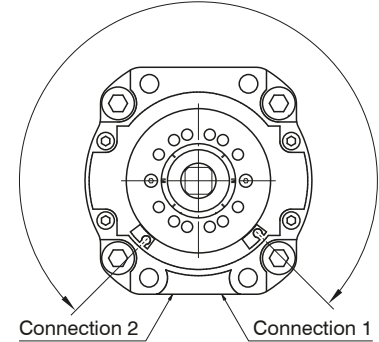
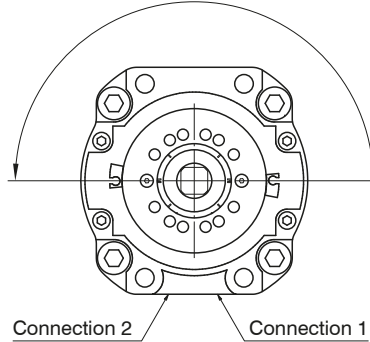
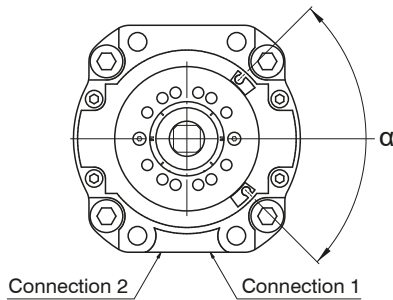

$\alpha$  - magnet rotating angle (that corresponds to the shaft key flat rotating angle)

For correct functionality position the switch within angle  $\alpha$

**Phase 4** - tighten screw (A)

**Phase 5** - repeat the following phases for the second switch

### AVAILABLE SENSORS

	Code
	1583.DC
	1583.HAP
	THR.P



Available torques

Ø10

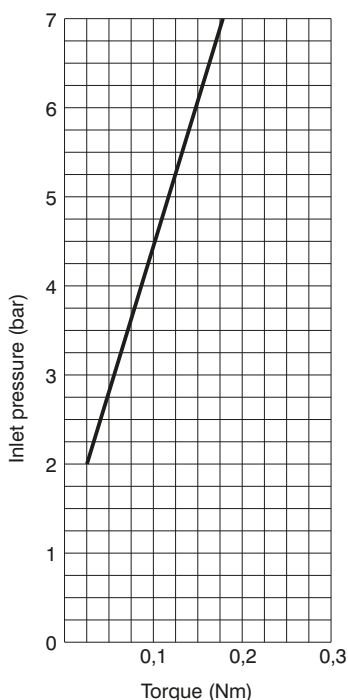

Ø15

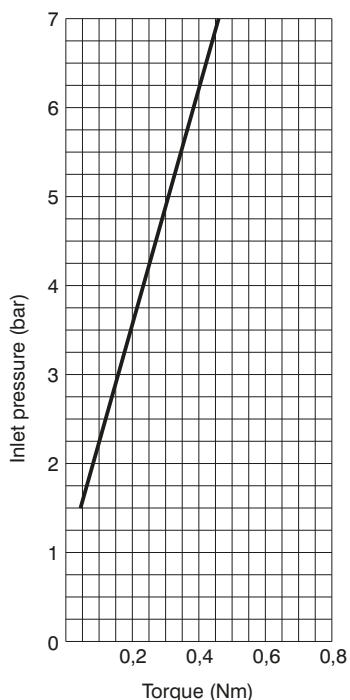

Ø20

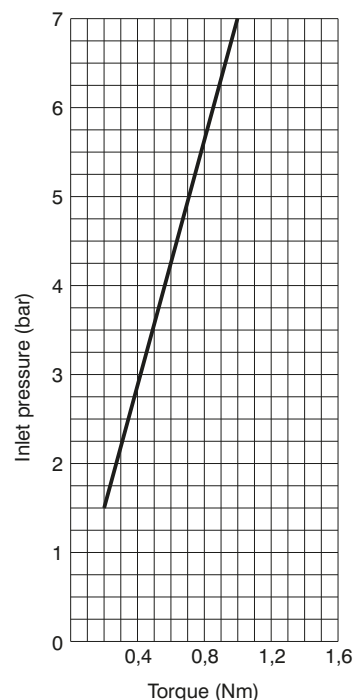

Ø30

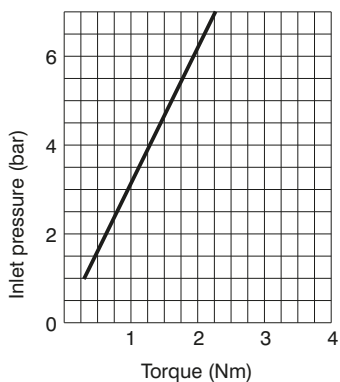

Ø40

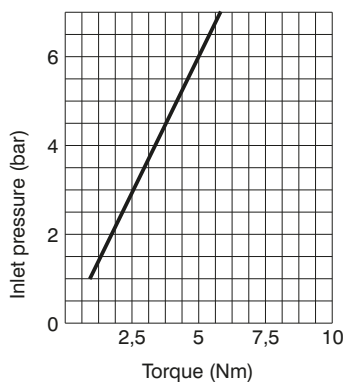

Ø50

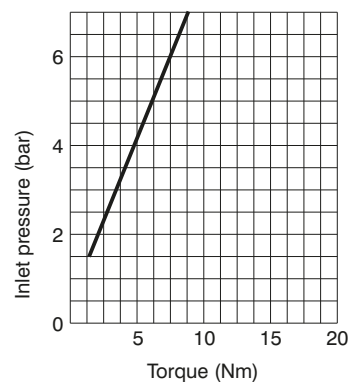

Ø63

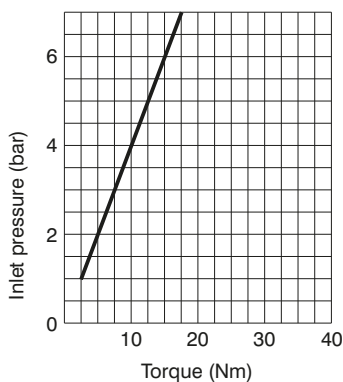

Ø80

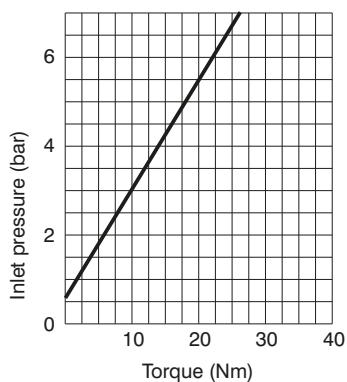

Ø100

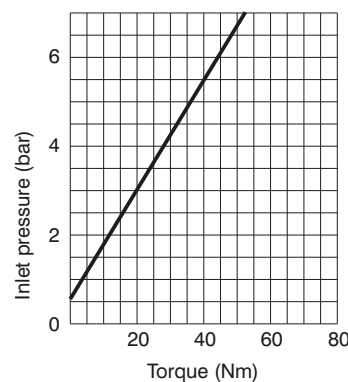

3

PNEUMATIC ACTUATION

Direct mounting  
Mounting types

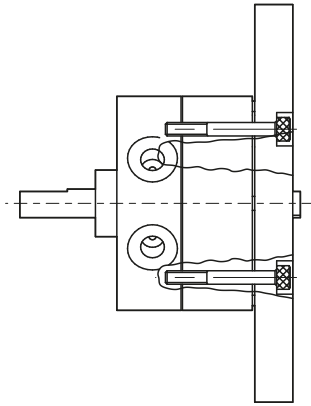

Rear mounting

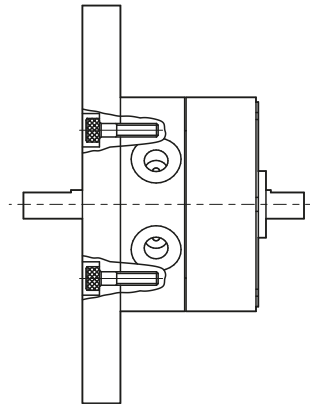

Frontal mounting

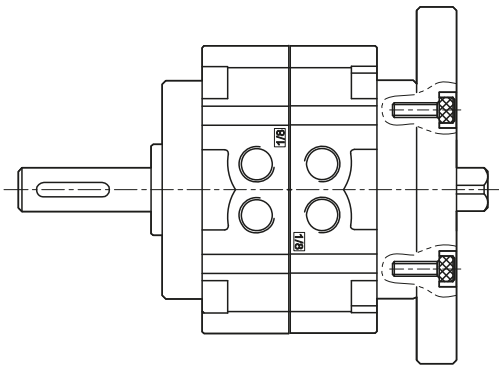

Rear mounting

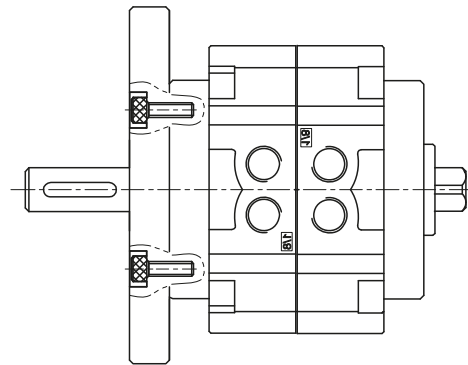

Frontal mounting

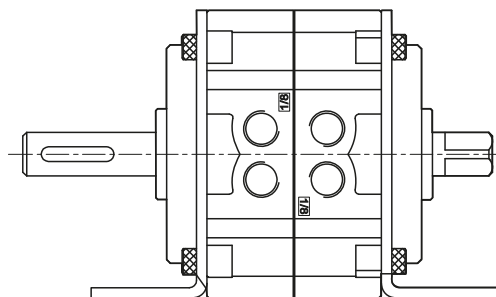

Mounting with flange