



Series AISI 316 stainless steel - Steel line

General

The 1393-1394 stainless steel ISO 15552 cylinders series are designed for corrosion resistance application such as marine, pharmaceutical and food ambiances.

The pre lubrication grease used is NSF H1 certified for food application.

Specific care has been taken during the design stages and the result is a clean profile cylinder easy to clean and free from possible residue build-up areas.

All parts in contact with the external environment are in Stainless steel 316L and the seals are available in two different compounds for different temperature applications: PUR -30°C - +80°C and FPM -5°C - +150°C.

The range starts from 32 bore up to 100 bore, round barrel and tie rods design. Double acting version standard or with through rod, magnetic or not magnetic piston available.

The piston is aluminium and the sensor bracket, when required is in stainless steel 316.

The cylinder can be fixed via the threaded holes in the tie rod nuts or with the wide range of stainless steel accessories.

Construction characteristics

End caps, piston rod, barrel, cushion screws	Stainless steel AISI 316
Rod-guide bushings	Stainless steel AISI 316 with P.T.F.E. coat
Half-pistons	Aluminium
Seals	PUR or FPM on request
Lubricating grease	NSF-H1 certified grease for incidental contact with food

Operational characteristics

Fluid	Filtered air. No lubrication needed, if applied it shall be continuous.
Max. pressure	10 bar
Operating temperature	-30° C - +80°C with PUR seals -5° C - +150°C with FPM seals and non magnetic piston -5° C - +80°C with FPM seals and magnetic piston
Bore	Ø 32 - 40 - 50 - 63 - 80 - 100
Cushioning length	mm 20 - 20 - 22 - 22 - 32 - 32

Please follow the suggestions below to ensure a long life for these cylinders:

- use clean and lubricated air
- correct alignment during assembly with regard to the applied load so as to avoid radial components or bending the rod.
- avoid high speeds together with long strokes and heavy loads: this would produce kinetic energy which the cylinder cannot absorb, especially if used as a limit stop (in this case use mechanical stop device)
- evaluate the environmental characteristics of cylinder used (high temperature, hard atmosphere, dust, humidity etc.)

Please note: air must be dried for applications with lower temperature.

Our Technical Department will be glad to help.

Standard strokes (for all diameters)

from 0 to 150, every 25 mm
over 150 up to 500, every 50 mm
over 500 up to 1000, every 100

Stroke tolerance (ISO 15552)

Bore	Stroke	Tolerance
32 - 40 - 50	up to 500	+2 0
	over 500 up to 1250	+3.2 0
63 - 80 - 100	up to 500	+2.5 0
	over 500 up to 1250	+4 0

On request are available strokes up to 2800 mm

Basic version "01"

Ordering code

1393.Ø.stroke.01 Magnetic
1394.Ø.stroke.01 Non magnetic

This is the configuration representing the basic cylinder according to ISO standards. It can be directly anchored on machine parts using the four threads on the end cap screws. For other applications see the pages about different types of stainless steel fixings.

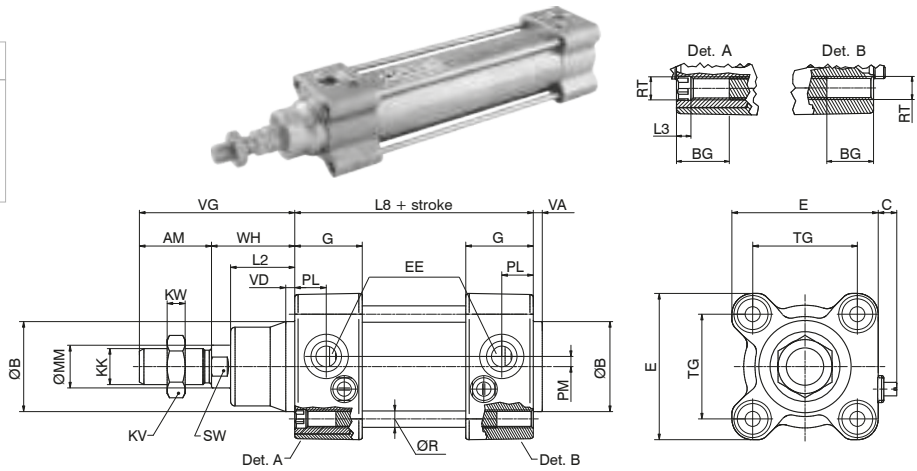

Through rod cylinder version - "02"

Ordering code

1393.Ø.stroke.02 Magnetic
1394.Ø.stroke.02 Non magnetic

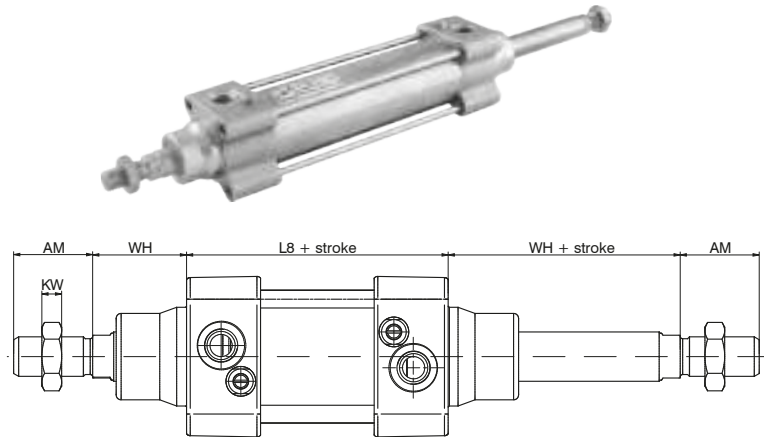

Variants

Version with FPM seals

Ordering code

139_(93.94) Ø.stroke._ _ V

Table of dimensions

Bore	32	40	50	63	80	100	
AM	22	24	32	32	40	40	
ØB (d 11)	30	35	40	45	45	55	
BG min.	16	16	16	16	18	17	
C	min.	4	4	4	3,5	3,5	
	max.	7,5	7,5	8,5	8,5	9	
E	47	52	65	76	95	113	
EE	G1/8"	G1/4"	G1/4"	G3/8"	G3/8"	G1/2"	
G	29	31	30	34	36	40,5	
KK	M10X1,25	M12X1,25	M16X1,5	M16X1,5	M20x1,5	M20X1,5	
KV	17	19	24	24	30	30	
KW	16	7	8	8	9	9	
L2	20	22	28,5	29	35	36	
L3	4,5	4,5	5	5	6	6	
L8	94	105	106	121	128	138	
ØMM	12	16	20	20	25	25	
PL	13	14	14	16	16	18	
PM	3	3,5	4,5	7	8	8	
ØR	Ø5,2	Ø5,2	Ø7,1	Ø7,1	Ø8,9	Ø8,9	
RT	M6	M6	M8	M8	M10	M10	
SW	10	13	17	17	22	22	
TG	32,5	38	46,5	56,5	72	89	
VA	4	4	4	4	4	4	
VD	4	4	4	4	4	4	
VG	48	54	69	69	86	91	
WH	26	30	37	37	46	51	
Weight	stroke 0	1000	1430	2150	3000	4400	6400
	g every 10 mm	35	45	63	80	120	135

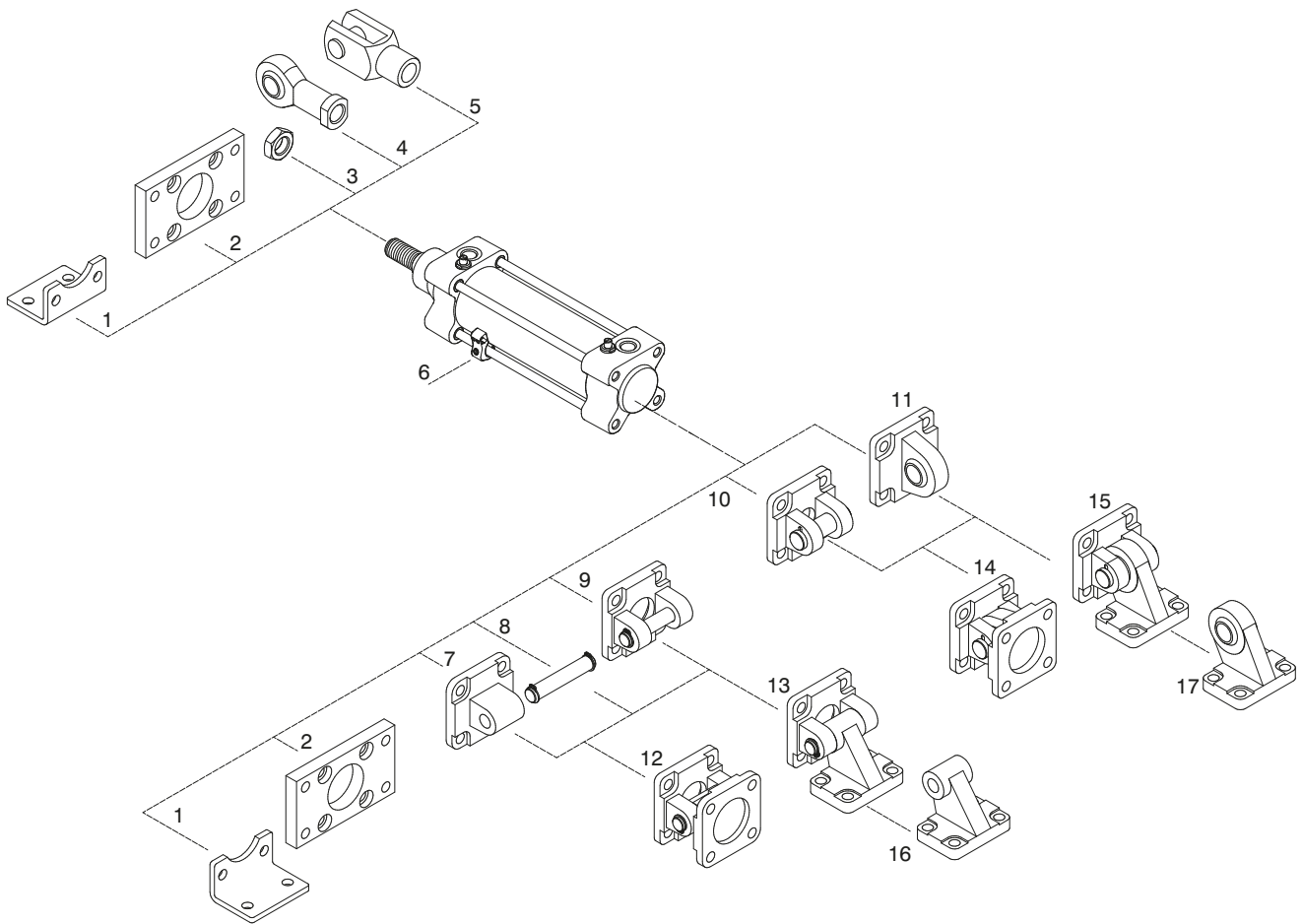

Position	Description	Ordering code	Materials
1	Short mounting foot brackets (MS1)	1393.Ø.05/1F	Stainless steel AISI 316
2	Flange (MF1-MF2)	1393.Ø.03F	Stainless steel AISI 316
3	Rod nut	1393.Ø.18F	Stainless steel AISI 316
4	Ball joint	1393.Ø.32F	Stainless steel
5	Fork	1393.Ø.13F	Stainless steel
6	Sensor bracket	1393._	Stainless steel AISI 316
7	Rear male clevis (MP4)	1393.Ø.09/1F	Stainless steel AISI 316
8	Pin (AA4) with circlips for rear clevis (MP2) (pos. 9)	1393.Ø.37F	Stainless steel AISI 316
9	Rear female clevis (MP2)	1393.Ø.09F	Stainless steel AISI 316
10	Rear narrow clevis (AB6)	1393.Ø.30F	Stainless steel AISI 316
11	Rear male clevis (with jointed head - MP6)	1393.Ø.15F	Stainless steel AISI 316
12	Standard complete trunnion (pos. 7 + pos. 9)	1393.Ø.22F	Stainless steel AISI 316
13	Square angle trunnion (pos. 9 + pos. 16)	1393.Ø.35F	Stainless steel AISI 316
14	Standard complete trunnion with jointed head (pos. 10 + pos.11)	1393.Ø.36F	Stainless steel AISI 316
15	Complete square angle trunnion (pos. 10 + pos.17)	1393.Ø.27F	Stainless steel AISI 316
16	Simple square counter clevis (AB7) (pos. 13)	1393.Ø.11/2F	Stainless steel AISI 316
17	Simple square counter clevis (pos. 15)	1393.Ø.28F	Stainless steel AISI 316

Sensor bracket

Ordering code

1393.A (Ø32 ... Ø40)
1393.B (Ø50 ... Ø63)
1393.C (Ø80 ... Ø100)



Fixing bracket made of stainless steel AISI 316 for sensor mounting on cylinders.

Sensors cod. **1580.**_
MRS._
MHS._



Bore	L
Ø32	51
Ø40	57
Ø50	67
Ø63	79
Ø80	98
Ø100	115

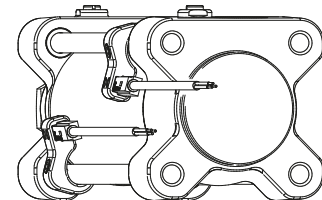
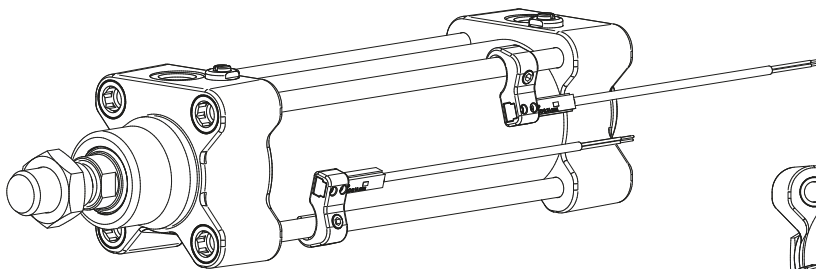
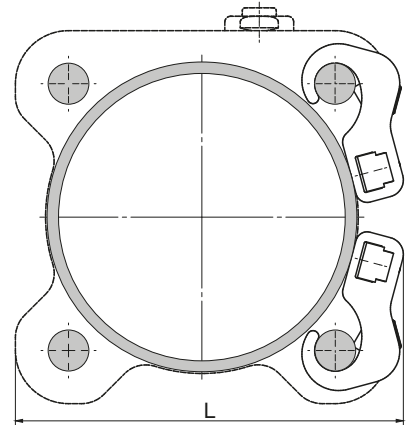

To mount the brackets on the tie rods use the dedicated stainless steel grub screw.

Front and rear flanges (MF1 - MF2)

Ordering code

1393.Ø.03F



Plate in stainless steel AISI 316 which allows anchorage of the cylinder at a right angle to the plane.

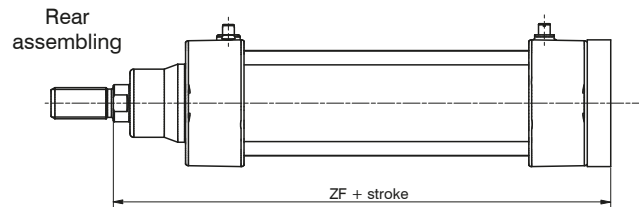
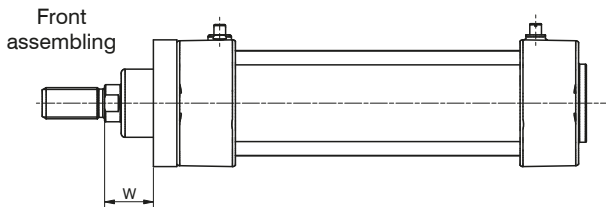
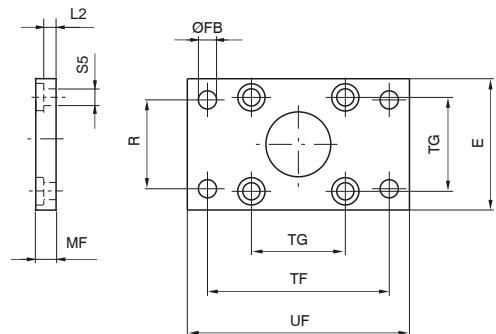

Bore	E	ØFB (H 13)	MF (JS 14)	R (JS 14)	TF (JS 14)	TG	UF	ZF	W	L2	ØS5	Weight (g)
32	45	7	10	32	64	32,5	80	130	16	5	6,6	190
40	52	9	10	36	72	38	90	145	20	5	6,6	250
50	65	9	12	45	90	46,5	110	155	25	6,5	9	480
63	75	9	12	50	100	56,5	120	170	25	6,5	9	620
80	95	12	15	63	126	72	150	189	31	7	11	1430
100	115	14	15	75	150	89	170	204	36	7	11	1990

Short mounting foot brackets (MS1)

Ordering code
1393.Ø.05/1F



Elements used to anchor the cylinder parallel to the mounting plane. They are made of stainless steel AISI 316.

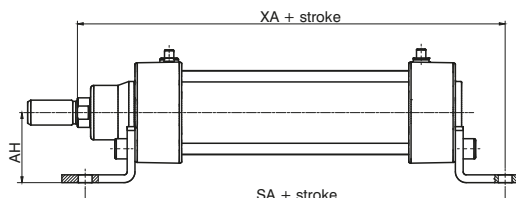
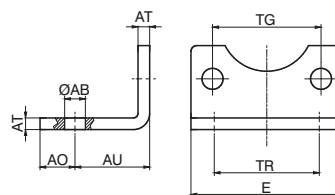

Bore	32	40	50	63	80	100
ØAB (H 14)	7	9	9	9	12	14
AH	32	36	45	50	63	71
AU (± 0.2)	24	28	32	32	41	41
AO	11	8	15	13	14	16
E	45	52	65	75	95	115
AT	4	4	5	5	6	6
SA	142	161	170	185	210	220
TG	32,5	38	46,5	56,5	72	89
TR (JS 14)	32	36	45	50	63	75
XA	144	163	175	190	215	230
Weight g	60	70	160	180	370	430

Rear clevis (MP2)

Ordering code
1393.Ø.09F



This type of mounting allows anchorage of the cylinder either parallel or right angle to plane; the cylinder rod can oscillate and self-align as necessary when under load. Made of stainless steel AISI 316.

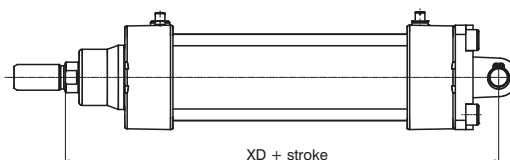
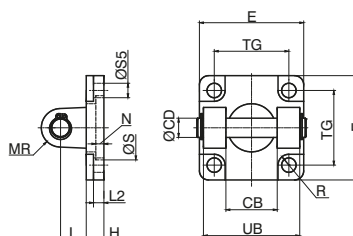

Bore	32	40	50	63	80	100
CB (H 14)	26	28	32	40	50	60
ØCD	10	12	12	16	16	20
E	45	55	65	75	95	115
ØS (H11)	30	35	40	45	45	55
N	5	5	5	5	/	/
R (H13)	5,5	5,5	7,5	7,5	9	9
H	10	10	10	12	14	16
L	12	15	17	20	22	25
MR	10	12	12	16	16	20
TG	32,5	38	46,5	56,5	72	89
UB (h14)	45	52	60	70	90	110
XD	142	160	170	190	210	230
L2 (±0,5)	5,5	5,5	6,5	6,5	10	10
S5 (H13)	6,6	6,6	9	9	11	11
Weight g	140	230	370	540	1000	1700

Rear male clevis (MP4)

Ordering code

1393.Ø.09/1F

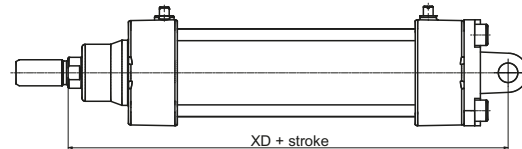
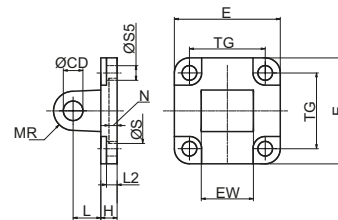

Similar to 09 clevis except for the connection, which is male rather than female. Used to mount the cylinder either parallel or at a right angle to the plane; the cylinder rod can oscillate and self-align as necessary when under load. Made of stainless steel AISI 316.

Bore	32	40	50	63	80	100
CD (H 9)	10	12	12	16	16	20
E	45	55	65	75	95	115
EW (^{-0.2} / _{-0.6})	26	28	32	40	50	60
H	10	10	10	12	14	16
L	12	15	17	20	22	25
ØS (H11)	30	35	40	45	45	55
N	5	5	5	5	/	/
R (H13)	5,5	5,5	7,5	7,5	9	9
MR	10	12	12	16	16	20
TG	32,5	38	46,5	56,5	72	89
XD	142	160	170	190	210	230
L2 (±0,5)	5,5	5,5	6,5	6,5	10	10
S5 (H13)	6,6	6,6	9	9	11	11
Weight g	180	280	370	680	1200	2100

Pin with circlips for rear clevis (MP4 and MP2)

Ordering code

1393.Ø.37F

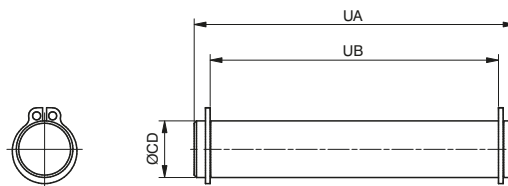

Stainless steel AISI 316 pin, complete with stainless steel circlips, which can be used with clevis code 1393.Ø.09/1F and 1393.Ø.09F

Bore	32	40	50	63	80	100
CD (e8)	10	12	12	16	16	20
UA	53	60	68	78	98	118
UB (^{-0.5} / ₋₀)	46	53	61	71	91	111
Weight g	35	50	60	120	150	290

Standard complete trunnion

Ordering code
1393.Ø.22F
Mounting consists of rear clevis code 1380.Ø09F
+rear male clevis code 1380.Ø.09/1F
(ordering separately)

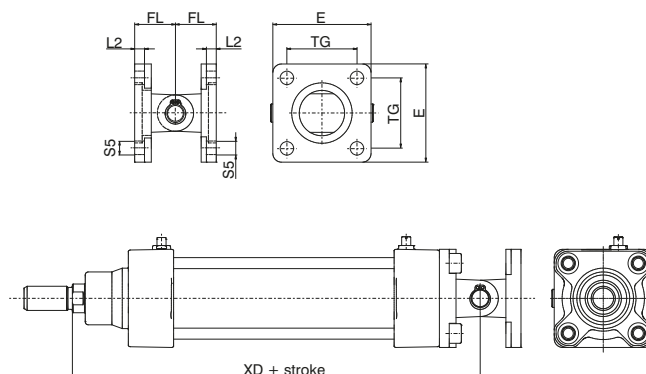

Made of stainless steel AISI 316.

Bore	32	40	50	63	80	100
E	45	55	65	75	95	115
FL	22	25	27	32	36	41
L 2 ($\pm 0,5$)	5,5	5,5	6,5	6,5	10	10
S 5	6,6	6,6	9	9	11	11
TG	32,5	38	46,5	56,5	72	89
XD	142	160	170	190	210	230
Weight g	360	580	780	1370	2370	4110

Square angle trunnion (AB7)

Ordering code
1393.Ø.35F
Counter clevis can be ordered
separately with code 1393.Ø.11/2F

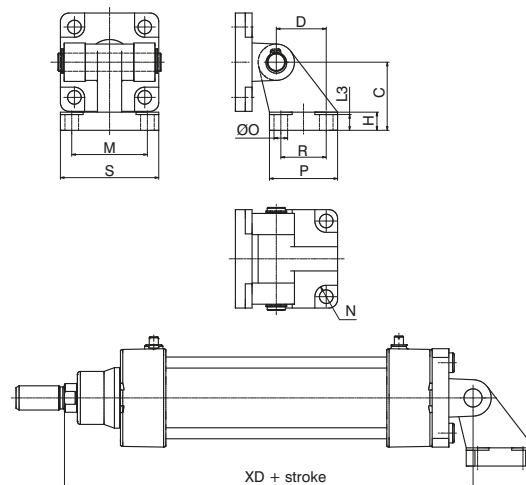

Made of stainless steel AISI 316.

Bore	32	40	50	63	80	100
D (JS 15)	21	24	33	37	47	55
C (JS 15)	32	36	45	50	63	71
H	8	10	12	12	14	15
N (H 13)	5,5	5,5	7,5	7,5	9	9
L3	6,5	8,5	10,5	10,5	11,5	12,5
R (JS 14)	18	22	30	35	40	50
P	31	35	45	50	60	70
O (H 13)	6,6	6,6	9	9	11	11
S	51	54	65	67	86	96
M (JS 14)	38	41	50	52	66	76
XD	142	160	170	190	210	230
Weight g	330	520	810	1200	2200	4710

Rear narrow clevis (AB6)

Ordering code

1393.Ø.30F

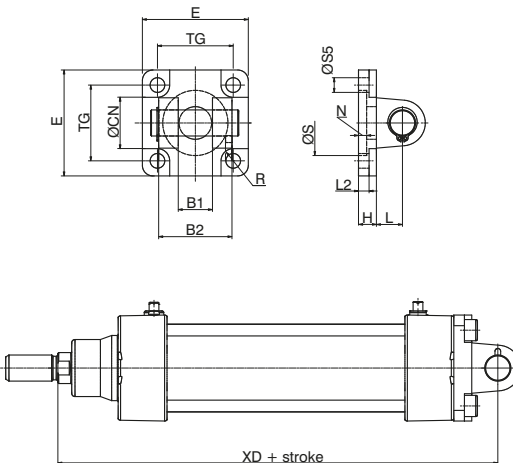

Bore	32	40	50	63	80	100
B1 (H 14)	14	16	21	21	25	25
B2 (h 14)	34	40	45	51	65	75
ØCN	10	12	16	16	20	20
E	45	55	65	75	95	115
H	10	10	10	12	14	16
L	12	15	17	20	22	25
L2 (±0,5)	5,5	5,5	6,5	6,5	10	10
S5 (H 13)	6,6	6,6	9	9	11	11
TG	32,5	38	46,5	56,5	72	89
XD	142	160	170	190	210	230
ØS (H 12)	30	35	40	45	45	55
R (H 13)	5,5	5,5	7,5	7,5	9	9
N	5	5	5	5	5	5
Weight g	170	270	420	650	1380	2050

Utilised with clevis 1393.Ø.15F allows the cylinder to oscillate in all directions (see standard complete trunnion 1393.Ø.36F)
Made of stainless steel AISI 316.

Rear male clevis (MP6) with jointed head according to DIN 648K standard

Ordering code

1393.Ø.15F

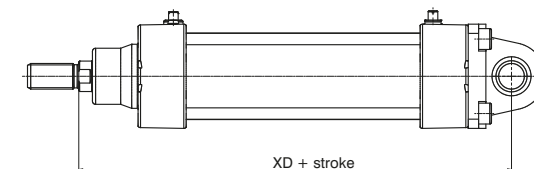
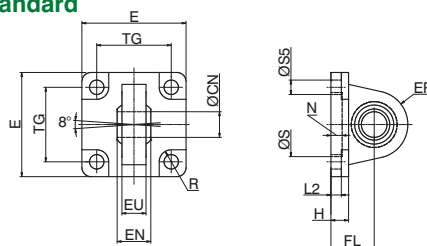
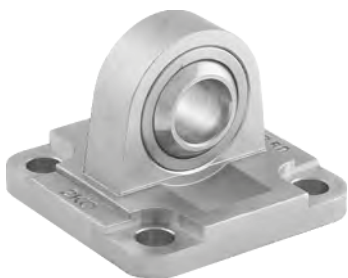

Bore	32	40	50	63	80	100
ØCN (H 7)	10	12	16	16	20	20
E	45	55	65	75	95	115
EN (-0.1)	14	16	21	21	25	25
ER	15	18	20	23	27	30
EU	10,5	12	15	15	18	18
FL (JS 15)	22	25	27	32	36	41
H	10	10	10	12	14	16
L2	5,5	5,5	6,5	6,5	10	10
S5 (H 13)	6,6	6,6	9	9	11	11
TG	32,5	38	46,5	56,5	72	89
XD	142	160	170	190	210	230
ØS (H 11)	30	35	40	45	45	55
R (H 13)	5,5	5,5	7,5	7,5	9	9
N	5	5	5	5	5	5
Weight g	150	260	370	600	1130	1800

Utilised with clevis 1393.Ø.30F allows the cylinder to oscillate in all directions.
Made of stainless steel AISI 316.

3 PNEUMATIC ACTUATION

► **Standard complete trunnion with jointed head according to DIN 648K standard**

Ordering code
1393.Ø.36F
Mounting consists of rear narrow clevis
code 1393.Ø.30F
with rear male clevis code 1393.Ø.15F

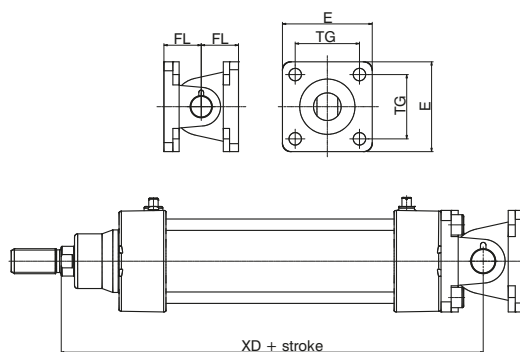

Made of stainless steel AISI 316.

Bore	32	40	50	63	80	100
E	45	55	65	75	95	115
FL (JS 15)	22	25	27	32	36	41
TG	32,5	38	46,5	56,5	72	89
XD	142	160	170	190	210	230
Weight g	320	530	790	1250	2510	3850

► **Complete square angle trunnion with jointed head acc. to DIN 648K standards**

Ordering code
1393.Ø.27F
Mounting consist of rear narrow clevis
cod. 1393.Ø.30F
with Simple square counter clevis cod. 1393.Ø.28F
(ordering separately)

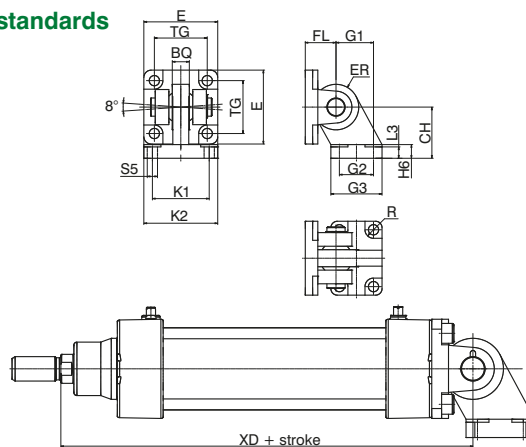
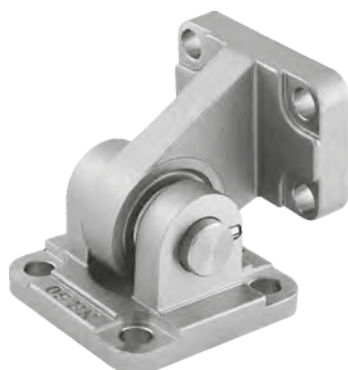

Made of stainless steel AISI 316.

Bore	32	40	50	63	80	100
CH (JS 15)	32	36	45	50	63	71
E	45	55	65	75	95	115
FL	22	25	27	32	36	41
G1 (JS 15)	21	24	33	37	47	55
G2 (JS 14)	18	22	30	35	40	50
G3	31	35	45	50	60	70
H6	10	10	12	12	14	15
K1 (JS 14)	38	41	50	52	66	76
K2	51	54	65	67	86	96
L3 (+0,5)	8,5	8,5	10,5	10,5	11,5	12,5
S5 (H13)	6,6	6,6	9	9	11	11
TG	32,5	38	46,5	56,5	72	89
XD	142	160	170	190	210	230
BQ	10,5	12	15	15	18	18
ER	15	18	20	23	27	30
R (H 13)	5,5	5,5	7,5	7,5	9	9
Weight g	350	540	880	1200	2350	3380

Rod fork and nuts

Ordering code

1393.Ø.13F

1393.Ø.18F

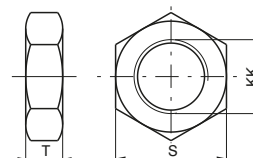
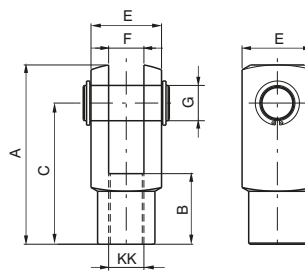

Fork:
Element that when screwed to the rod consents a regular functioning even when there are significant lateral forces as the connection point.
Made of stainless steel AISI 303.

Nut:
Used to block the position of the fork.
Made of stainless steel AISI 316.

Bore	32	40	50	63	80	100
A	52	62	83	83	105	105
B	20	24	32	32	40	40
C	40	48	64	64	80	80
E	20	24	32	32	40	40
F(B13)	10	12	16	16	20	20
G	10	12	16	16	20	20
S	17	19	24	24	30	30
T	6	7	8	8	9	9
KK	M10X1,25		M12X1,25	M16X1,5	M16X1,5	M20X1,5
Weight	fork	100	140	340	340	680
g	Nut	15	20	20	20	40

Ball joint

Ordering code

1393.Ø.32F

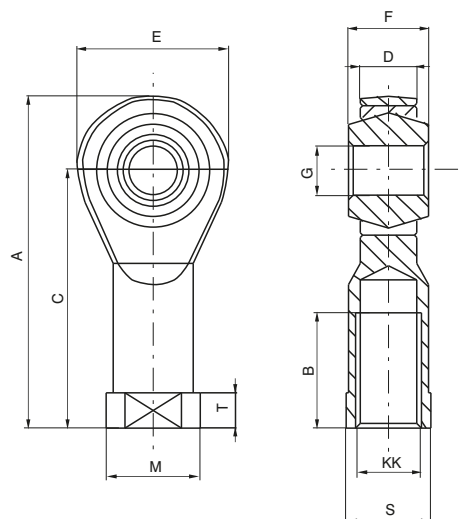

Balljoint:
Mounted on the rod thread, assures a regular operation even in the presence of significant forces to the linked element.
Made of stainless steel AISI 304 and 420.

Bore	32	40	50	63	80	100
A	57	66	85	85	102	102
B	20	22	28	28	33	33
C	43	50	64	64	77	77
D	10,5	12	15	15	18	18
E	28	32	42	42	50	50
F	14	16	21	21	25	25
G (H 7)	10	12	16	16	20	20
KK	M10x1,25	M12x1,25	M16x1,5	M16x1,5	M20x1,5	M20x1,5
M	19	22	27	27	34	34
S	17	19	22	22	30	30
T	6,5	6,5	8	8	10	10
Weight g	75	110	220	220	410	410