



Series 1390-1391-1392, ECOLIGHT

Construction characteristics

End caps	die-casting aluminium
Rod	C43 chromed steel or stainless steel
Barrel	aluminium alloy anodised
Rod-guide bushing	spheroid bronze on steel band with P.T.F.E. coat
Piston	Ø32 - Ø100 acetal resin, aluminium on request Ø125 - Ø200 aluminium V, Q, R, L versions (Ø32 - Ø100): aluminium
Seals	standard: NBR oil resistant rubber, PUR piston rod seals V version: FPM P version: PUR Q version: NBR and PUR with plastic rod scraper with a high wear resistance R version: PUR with metallic rod scraper L version: special PUR
Cushion adjusting screws	brass

Operational characteristics

Fluid	Filtered air. No lubrication needed, if applied it shall be continuous. L version (for low temperature): dried air, guarantee a dew point lower than the minimum operating temperature
Max. pressure	10 bar
Operating temperature	-5°C - +70°C with standard seals -30°C - +80°C with PUR seals (P version) -5°C - +80°C with FPM seals for 1390 and 1391 series (magnetic piston) (V version) -5°C - +150°C with FPM seals for 1392 series (no magnetic piston) (V version) -20°C - +80°C (Q version) -10°C - +80°C (R version) -50°C - +80°C (L version)
Bore	Ø 32 - 40 - 50 - 63 - 80 - 100 - 125 - 160 - 200
Cushioning length	mm 27 - 31 - 31 - 37 - 40 - 44 - 44 - 50 - 55
Cushion length version with aluminum piston	mm 20 - 20 - 22 - 22 - 32 - 32 - / - / - /

PNEUMATIC ACTUATION 3



Please follow the suggestions below to ensure a long life for these cylinders:

- use clean and lubricated air
- correct alignment during assembly with regard to the applied load so as to avoid radial components or bending the rod;
- avoid high speeds together with long strokes and heavy loads: this would produce kinetic energy which the cylinder cannot absorb, especially if used as a limit stop (in this case use mechanical stop device and the aluminium piston);
- evaluate the environmental characteristics of cylinder used (high temperature, hard atmosphere, dust, humidity etc.)

VERSIONS WITH ADDITIONAL ROD SCRAPER

Version with plastic rod scraper (Q)

The pneumatic seal is manufactured using a special NBR seal material, with the rod scraper that comes in contact with the external environment made of a plastic material with a high wear resistance. The geometric shape with its excellent scraping capacity guarantees additional protection of the piston rod and nose seal against the impurities, liquids, water, and debris.

Version with metallic rod scraper (R)

The pneumatic seal is manufactured using a special FPM seal material with its own scraping lip with the additional rod scraper that comes into contact with the external environment made of metal. This combination of scraping lip and metal rod scraper enable these actuators to be used in particularly extreme environments.

Here are some examples:

Aluminum foundries: To remove the residues of alumina or fluorine compounds that are deposited on the piston rod during the preparation phase of aluminum casting.

Automotive: To prevent debris which has collected on the piston rod damaging the nose seal during operation especially waste produced during the welding process.

Industrial ovens: To eliminate cement powders or those produced during the manufacture of bricks/tiles

Thanks to the high-performance nose seal and scraper protection of the piston rod, the cylinder will be protected against premature wear that you would normally experience using standard cylinders in these harsh environments.

Low temperature version (L): The special seals compound allows the use of the cylinders up to a temperature of -50°C. The rod scraper seal is equipped with a metallic scraper which removes ice crystals which might form at minus temperature

Please note: air must be dry for applications with lower temperature.

Use hydraulic oils H class (ISO VG32) for correct continued lubrication.

Our Technical Department will be glad to help.

Standard strokes (for all diameters)

from 0 to 150, every 25 mm
from 150 to 500, every 50 mm
from 500 to 1000, every 100 mm

On request are available strokes up to 2800 mm

Stroke tolerance (ISO 15552)

Bore	Stroke	Tolerance
32 - 40 - 50	up to 500	+2 0
	over 500 up to 1250	+3.2 0
63 - 80 - 100	up to 500	+2.5 0
	over 500 up to 1250	+4 0
125 - 160 - 200	up to 500	+4 0
	over 500 up to 1250	+5 0

Basic version "01"

Ordering code

- 1390.Ø.stroke.01** Magnetic chromed rod
- 1391.Ø.stroke.01** Magnetic stainless steel rod
- 1392.Ø.stroke.01** Non magnetic chromed rod

This is the configuration representing the basic cylinder according to ISO-VDMA standards. It can be directly anchored on machine parts using the four threads on the end cap screws. For other applications see "Cylinder section" on the General Catalogue, where different types of attachments are shown.

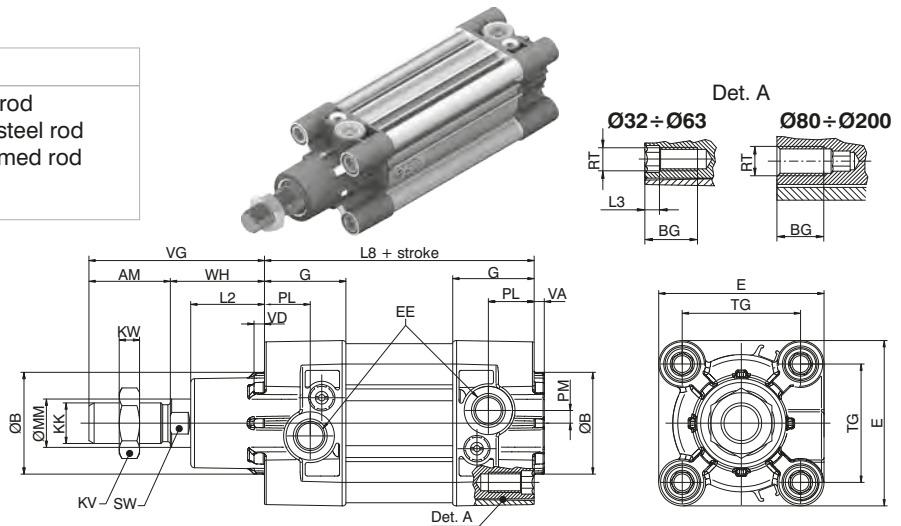

Through rod cylinder version "02"

Ordering code

- 1390.Ø.stroke.02** Magnetic chromed rod
- 1391.Ø.stroke.02** Magnetic stainless steel rod
- 1392.Ø.stroke.02** Non magnetic chromed rod

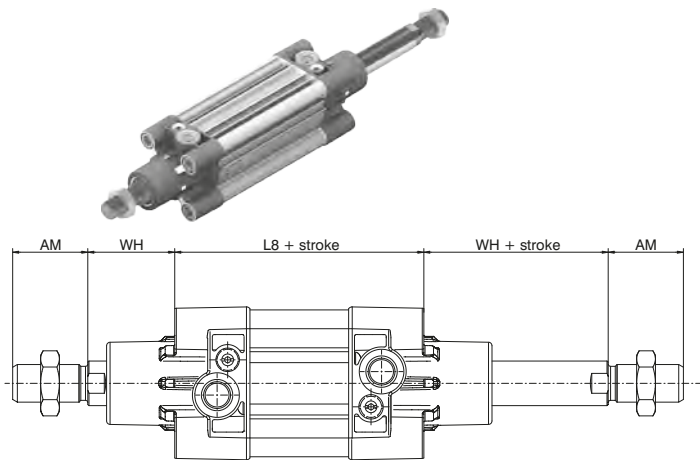

Tandem push with common rods "G"

Ordering code

- 1390.Ø.stroke.G** Magnetic chromed rod
- 1391.Ø.stroke.G** Magnetic stainless steel rod
- 1392.Ø.stroke.G** Non magnetic chromed rod

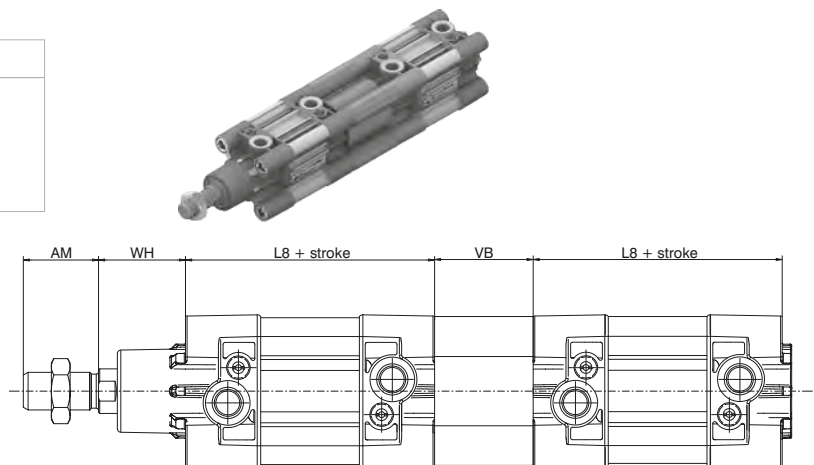

Tandem push with independent rods "F"

Ordering code

- 1390.Ø.stroke.stroke1.F** Magnetic chromed rod
- 1391.Ø.stroke.stroke1.F** Magnetic stainless steel rod
- 1392.Ø.stroke.stroke1.F** Non magnetic chromed rod

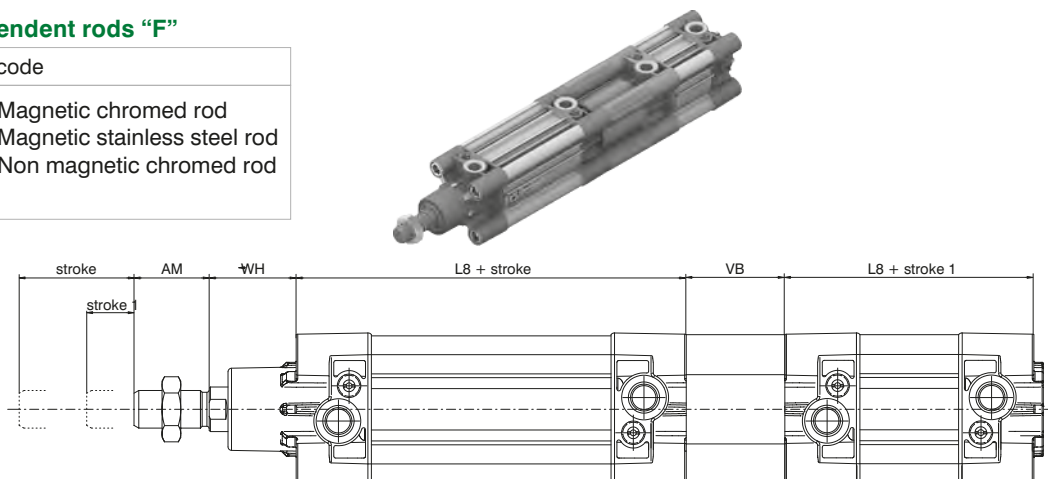

► **Opposed tandem with common rod "D"**

Ordering code

1390.Ø.stroke.stroke1.D Magnetic chromed rod
1391.Ø.stroke.stroke1.D Magnetic stainless steel rod
1392.Ø.stroke.stroke1.D Non magnetic chromed rod

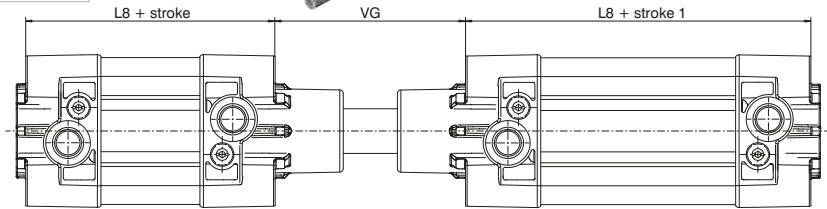
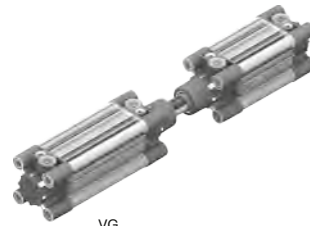

► **Tandem with opposed rods - "E"**

Ordering code

1390.Ø.stroke.stroke1.E Magnetic chromed rod
1391.Ø.stroke.stroke1.E Magnetic stainless steel rod
1392.Ø.stroke.stroke1.E Non magnetic chromed rod

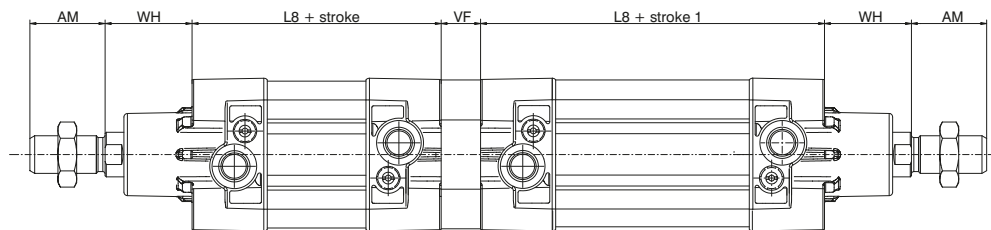

Variants

Ordering code

139_Ø.stroke._.P = Version with PUR seals
139_Ø.stroke._.K = Version with aluminium piston (from Ø32 to Ø100)
139_Ø.stroke._.PK = Version with PUR seals and aluminium piston (from Ø32 to Ø100)
139_Ø.stroke._.V = Version with FPM seals and aluminium piston
139_Ø.corsa._.R = Version with metallic rod scraper and aluminium piston (Ø32-Ø100)
139_Ø.corsa._.Q = Version with plastic rod scraper and aluminium piston (Ø32-Ø100)
139_Ø.stroke._.PQ = Version with PUR seals and plastic rod scraper and aluminium piston (Ø32-Ø100)
139_Ø.corsa._.L = Version for low temperature and aluminium piston (-50°C) (Ø32-Ø100)

Table of dimensions

Bore	32	40	50	63	80	100	125	160	200	
AM	22	24	32	32	40	40	54	72	72	
B (d 11)	30	35	40	45	45	55	60	65	75	
BG	16	16	18	18	16	16	21	25	25	
E	47	54	65	76	95	113	138	180	216	
EE	G 1/8"	G 1/4"	G 1/4"	G 3/8"	G 3/8"	G 1/2"	G 1/2"	G 3/4"	G 3/4"	
G	29.5	33	32	36	38.5	41.5	48	49	49	
KK	M10X1.25	M12X1.25	M16x1.5	M16x1.5	M20x1.5	M20x1.5	M27x2	M36x2	M36x2	
KV	17	19	24	24	30	30	41	55	55	
KW	6	7	8	8	9	9	12	18	18	
L2	19	22	29	29	35	36	45	50	60	
L3	4	4	5	5	/	/	/	/	/	
L8	94	105	106	121	128	138	160	180	180	
MM	12	16	20	20	25	25	32	40	40	
PL	13	16	18	18	16	18	25	26	25	
PM	3	4	5	4.5	2.5	6	8	11	11	
RT	M6	M6	M8	M8	M10	M10	M12	M16	M16	
SW	10	13	17	17	22	22	27	36	36	
TG	32.5	38	46.5	56.5	72	89	110	140	175	
VA	4	4	4	4	4	4	6	6	6	
VB	33	41	51	51	65	71	75	70	75	
VD	4	4	4	4	4	4	6	6	6	
VF	12	12	16	16	20	20	25	30	30	
VG	48	54	69	69	86	91	119	152	167	
WH	26	30	37	37	46	51	65	80	95	
Weight	stroke 0	460	650	1030	1360	2180	2890	5700	11200	14900
	every 10 mm	23	32	45	49	75	81	130	195	245

On the ECOLIGHT series it is possible to use three sensor types, according to bore, as indicated below:

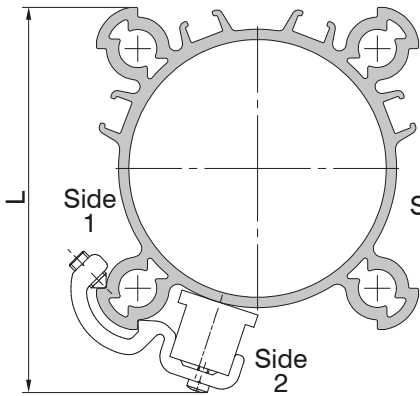

Ø32 - Ø100: the sensors can be fixed on the three sides as indicated in the drawing, by using suitable brackets (except for Ø32 on side 2)

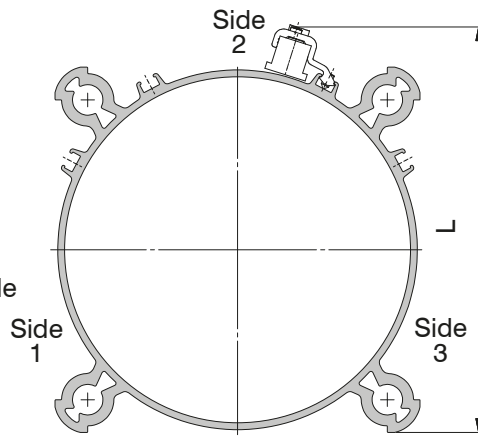

Ø125 - Ø200: the sensors can be fixed on the three sides as indicated in the drawing, by using suitable bracket

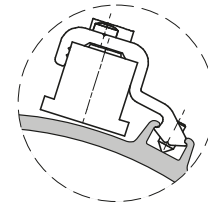

Code	Bore	L
1390.A	Ø32	58
	Ø40	65
1390.B	Ø50	75
	Ø63	86
1390.C	Ø80	105
	Ø100	122
1390.D	Ø125	150
	Ø160	190
	Ø200	225

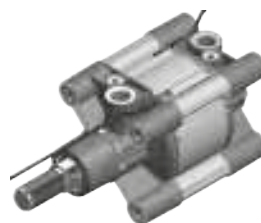
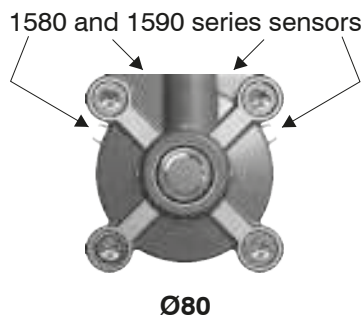
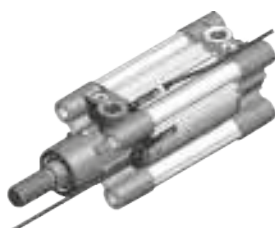
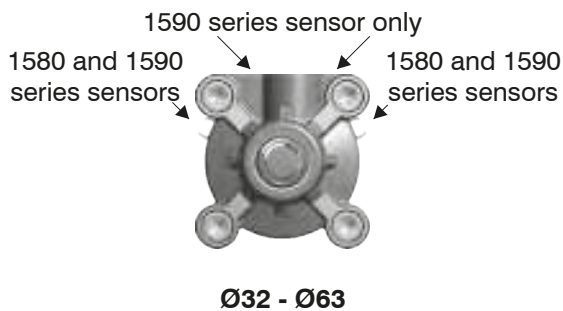
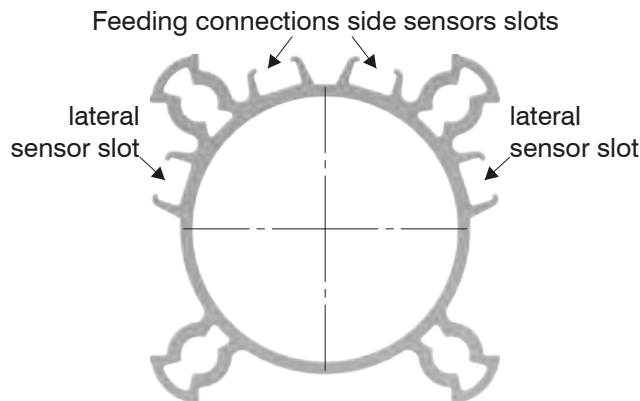

CYLINDERS - BORE SIZE Ø80:
 The two top housing can be accessed from the front of the unit, one housing can be accessed from the front end cap and the opposite housing from the rear end cap. It is therefore possible to use both type of sensors: 1580 - 1590.

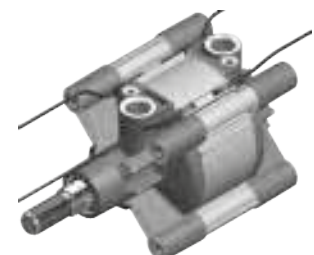
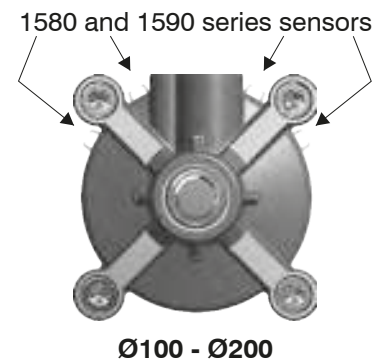

CYLINDERS - BORE SIZE Ø100-Ø200:
 All four housings can be accessed from the front of the unit. It is therefore possible to use both type of sensors: 1580 - 1590.

CYLINDERS - BORE SIZES Ø32 to Ø63:

The two slots on connection side are plugged, therefore only sensor 1590 can be used. Suitable for top housing and once placed by means of its screw, it can be fixed in desired position.

Solenoid valves supports

This accessory permits to mount a valve or an electrovalve on a side of the cylinder. The plate can be fitted on the cylinder profiled barrel. Once installed the connections must be done with fittings and pipes. All of the threaded holes on the support plate are dedicated to different valves series as per attached drawing.

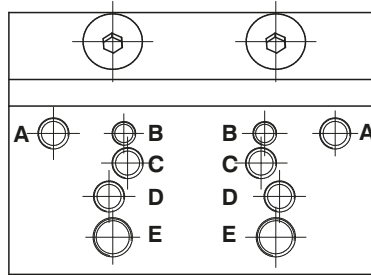

Fixing holes for valves series:

- A = 488 / 484
- B = 2400
- C = T488
- D = 2600
- E = T424

Ordering code
1390.25 (for Ø32)
1390.26 (for Ø40)
1390.27 (for Ø50)
1390.28 (for Ø63)
1390.29 (for Ø80)
1390.30 (for Ø100)

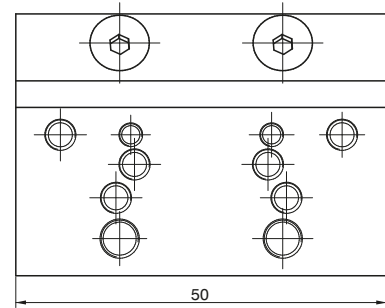
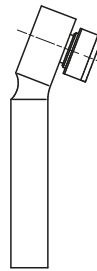

Attention: do not use ISO distributor for base mounting