



Series 6200 - Twin-rod slide units

General

TWIN-ROD SLIDE UNITS SERIES 6200 AND 6210

The 6200 series twin-rod linear guide units are wide cylinders used in manipulation applications and are characterised by their high force output thanks to their double piston design.

Bores range from 10mm to 32mm diameter, with sintered bronze bearings for standard applications and linear ball bearings for more rugged applications.

One major characteristic of these cylinders is the precision of their anti-rotational design, with the possibility of regulating the stroke to within 0.5mm.

When using magnetic sensors, the 1580 series sensor sits entirely within the extrusion, resulting in a smooth profile.

The liner guided units range includes , alongside the conventional two rod version with flange series 6200 , also the through rod version with twin flanges series 6210

Thanks to the twin-rod, double yoke design of the 6210 series it is possible to either fix the body and use the ends of the rods, or alternatively to fix the rod ends and use the body as the moving part. The cylinder can be piped through the body or through the rods depending on the application.

Stroke limiting screws are fitted at either end of the stroke. The substitution of these screws with shock absorbers makes it possible to use the cylinder on higher velocity applications (up to 500mm/sec.) Slots are provided along the edge of these units to accommodate 1580 series miniature sensors.

► Twin-rod slide units



Ordering code

6200.Ø.stroke.

- 10
- 15
- 20
- 25
- 32

- B = Control unit with bronze bush
- C = Control unit with bearing bush

Construction characteristics

Body	anodised aluminium
Rods	C43 chromed steel (control unit with bronze bush) tempered and chromed steel (control unit with bearing bush)
Piston	aluminium
Rod bushing	brass
End cap	anodised aluminium
Piston seal	oil resistant NBR rubber
Piston rod seal	PUR
Plate	anodised aluminium

Operational characteristics

Function	double acting
Fluid	Filtered air. No lubrication needed, if applied it shall be continuous.
Max. pressure	7 bar
Working temperature	-5°C - +70°C
Cushioning	elastic bumper

Standard strokes

Bore	Stroke														
	10	15	20	25	30	35	40	45	50	60	70	75	80	90	100
Ø10	●	●	●	●	●	●	●	●	●	●	●	●			
Ø15	●	●	●	●	●	●	●	●	●	●	●	●	●	●	●
Ø20	●	●	●	●	●	●	●	●	●	●	●	●	●	●	●
Ø25	●	●	●	●	●	●	●	●	●	●	●	●	●	●	●
Ø32	●	●	●	●	●	●	●	●	●	●	●	●	●	●	●

Overall dimensions Ø10 - Ø15

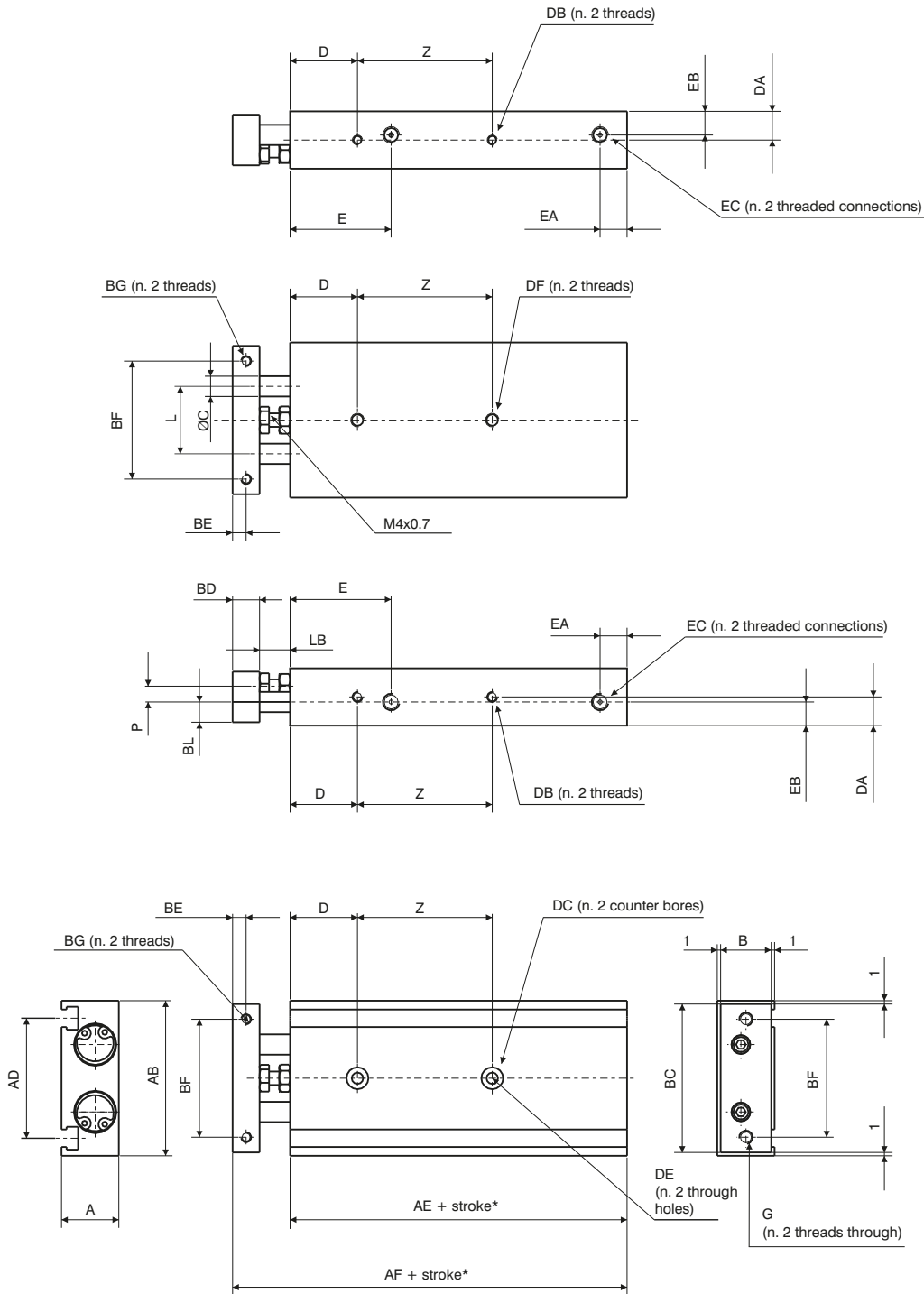

*Dimensions only refer to the "standard stroke"

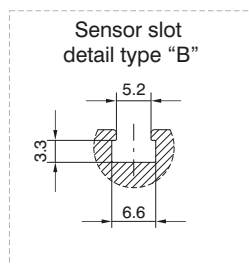

Bore	Ø10	Ø15	
A	17	20	
AB	46	58	
AD	35,6	48	
AE	55	60	
AF	72	79	
B	15	18	
BC	44	56	
BD	8	10	
BE	4	5	
BF	35	45	
BG	M3x0,5	M4x0,7	
Useful depth	5	6	
BL	6	9	
C	6	8	
D	20	30	
DA	8,5	10	
DB	M3x0,5	M4x0,7	
Useful depth	4,5	5	
DC	6,5	8	
depth	3,3	4,4	
DE	3,4	4,3	
DF	M4x0,7	M5x0,8	
Useful depth	7	8	
E	30	38,5	
EA	8	8	
EB	7	10	
EC	M5x0,8	M5x0,8	
Useful depth	4,5	4,5	
F	M4x0,7	M4x0,7	
G	M4x0,7	M5x0,8	
L	20	25	
LB	9	9	
P	4,7	4,5	
Z stroke	10 - 25	30	25
	30 - 50	40	35
	60 - 75	50	45
	80	-	45
	90-100	-	55

Overall dimensions Ø20 - Ø25 - Ø32

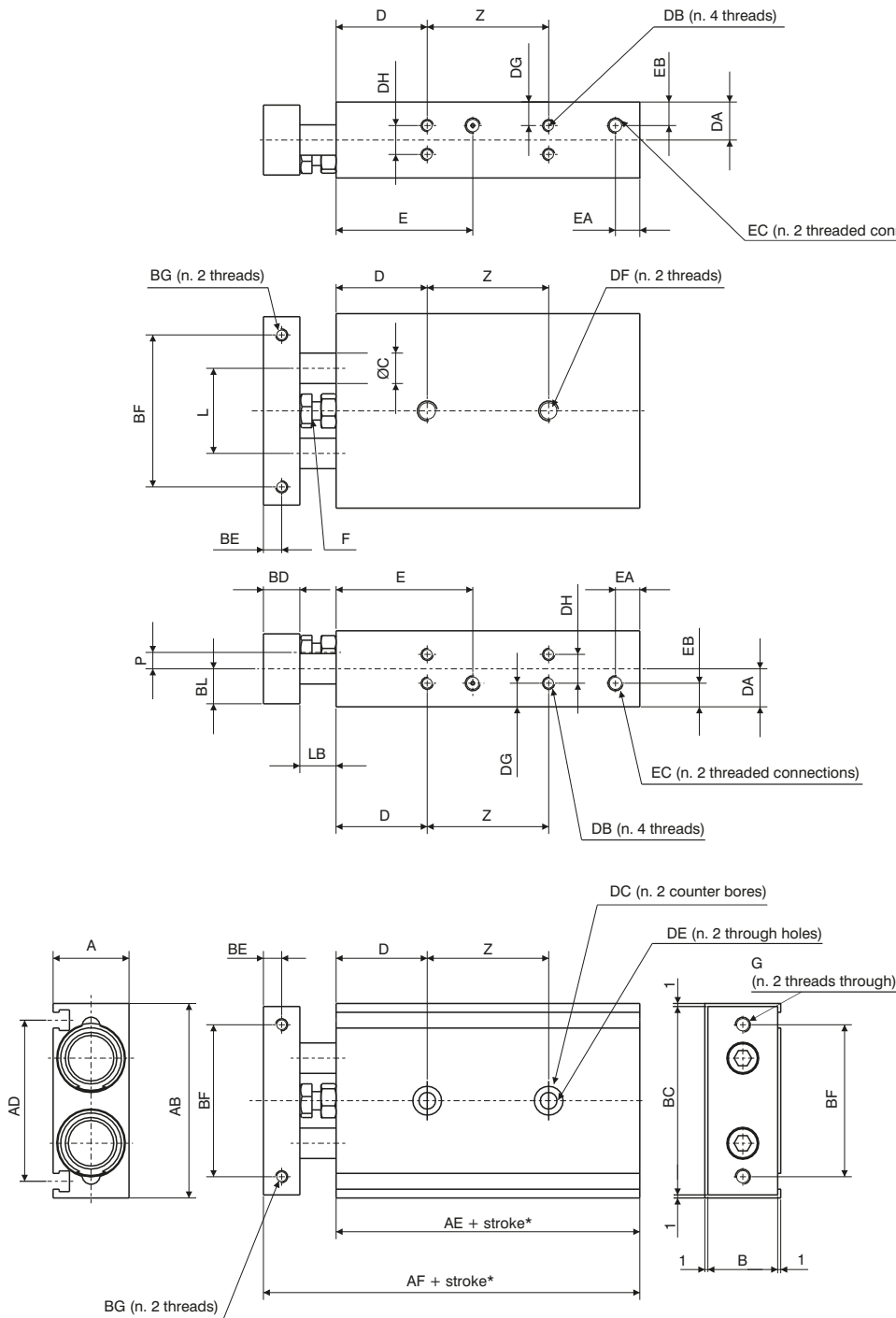

*Dimensions only refer to the "standard stroke"

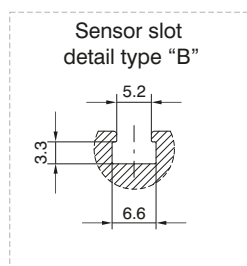

Bore		Ø20	Ø25	Ø32	
A		25	30	38	
AB		64	80	98	
AD		53	64	76	
AE		70	72	82	
AF		94	96	112	
B		23	28	36	
BC		62	78	96	
BD		12	12	16	
BE		6	6	8	
BF		50	60	75	
BG		M4x0,7	M5x0,8	M5x0,8	
	Useful depth	6	7,5	8	
BL		11,5	14	18	
C		10	12	16	
D		30	30	30	
DA		12,5	15	19	
DB		M4x0,7	M5x0,8	M5x0,8	
	Useful depth	6	7,5	7,5	
DC		9,5	11	11	
	depth	5,3	6,3	6,3	
DE		5,5	6,9	6,9	
DF		M6x1	M8x1,25	M8x1,25	
	Useful depth	10	12	12	
DG		7,75	8,5	9	
DH		9,5	13	20	
E		45	46	56	
EA		8	9	10	
EB		7,75	15	19	
EC		M5x0,8	G1/8	G1/8	
	Useful depth	4,5	6,5	6,5	
F		M6x1	M6x1	M8x1,25	
G		M5x0,8	M6x1	M6x1	
L		28	35	44	
LB		12	12	14	
P		5,4	7,8	12	
Z	stroke	10 - 25	30	30	40
		30 - 50	40	40	50
		60 - 100	60	60	70



Operating instructions

	Bore										
	Ø10		Ø15		Ø20		Ø25		Ø32		
Stroke	Control unit with bronze bush										Weight g
10	150	250	400	610	1150						
15	160	265	420	635	1190						
20	170	280	440	660	1230						
25	180	290	460	690	1275						
30	190	300	480	720	1320						
35	200	315	495	745	1360						
40	210	330	510	770	1400						
45	220	345	530	800	1450						
50	230	360	550	830	1490						
60	250	390	585	890	1580						
70	270	420	620	950	1665						
75	280	435	640	970	1710						
80		450	660	995	1755						
90		480	700	1060	1840						
100		510	740	1000	1930						
Stroke	Control unit with bearing bush										
10	160	270	430	620	1160						
15	165	285	445	645	1205						
20	170	300	460	670	1250						
25	180	310	480	700	1295						
30	190	320	500	730	1340						
35	200	335	515	755	1380						
40	210	350	530	780	1420						
45	220	365	550	810	1465						
50	230	380	570	840	1510						
60	250	410	605	895	1595						
70	270	440	640	955	1680						
75	280	455	660	980	1720						
80		470	680	1005	1765						
90		500	715	1065	1855						
100		530	750	1110	1940						
Working pressure	Theoretical slide force										
1 bar	16	10	35.5	25	63	47	98	75.5	161	120.5	
1.5 bar	23.5	15	53	38	94	62.5	147.5	113.5	241	181	
2 bar	31.5	20.0	70.5	50.5	125.5	94	196.5	151	321.5	241	
3 bar	47	30	106	75.5	188.5	141	294.5	227	482.5	362	
4 bar	63	40	141	101	251	188	393	302.5	643	482.5	
5 bar	78.5	50	176.5	126	314	236	491	378	804	603	
6 bar	94	60	212	151	377	283	589	453.5	965	723.5	
7 bar	110	70	247	176.5	440	330	687.5	529	1125.6	844	
	Out	In	Out	In	Out	In	Out	In	Out	In	

3 PNEUMATIC ACTUATION

Operating instructions

Possible loads

Control unit with bronze bush

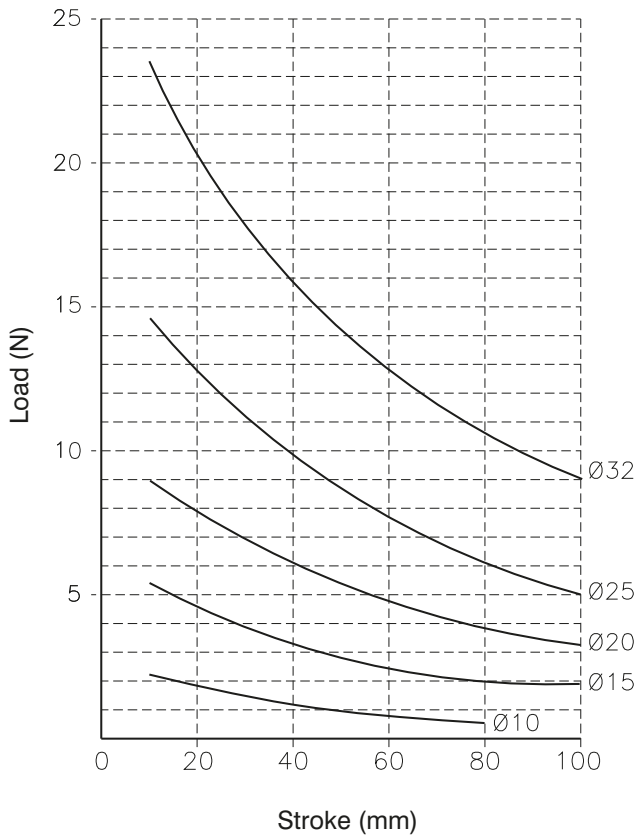

Control unit with bearing bush

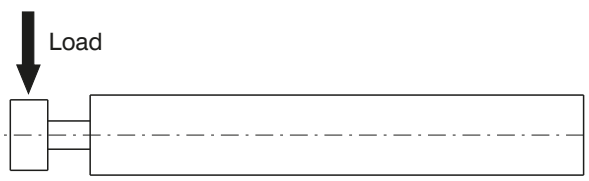
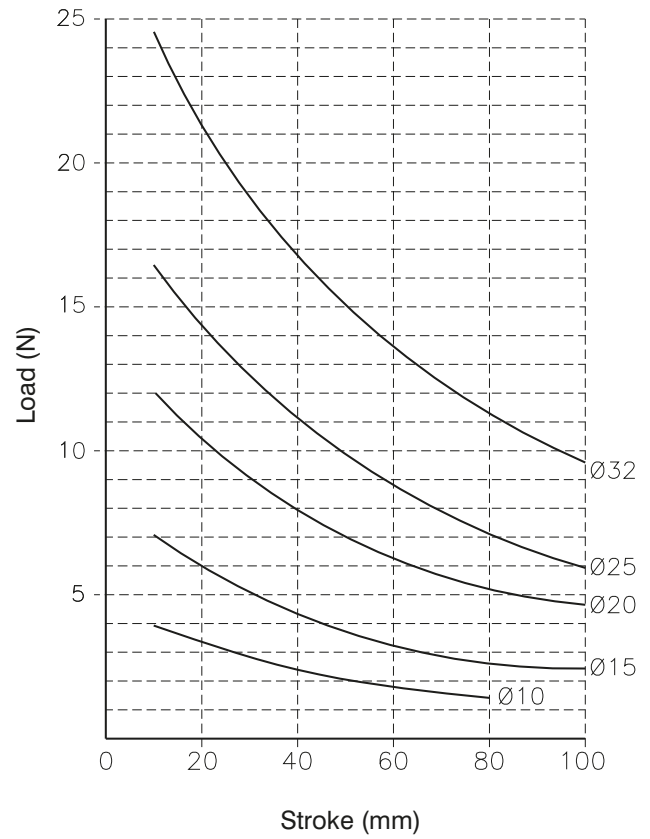

3 PNEUMATIC ACTUATION

Twin-rod slide units



Ordering code

6200.Ø.stroke.
 10
 15
 20
 25
 32
 B = Control unit with bronze bush
 C = Control unit with bearing bush

3 PNEUMATIC ACTUATION

Construction characteristics

Body	anodised aluminium
Rods	C43 chromed steel (control unit with bronze bush) tempered and chromed steel (control unit with bearing bush)
Piston	aluminium
Rod bushing	brass
End plate	anodised aluminium
Piston seal	oil resistant NBR rubber
Piston rod seal	PUR
Plate	anodised aluminium

Technical characteristics

Function	double acting
Fluid	Filtered air. No lubrication needed, if applied it shall be continuous.
Max. pressure	7 bar
Working temperature	-5°C - +70°C
Cushioning	elastic bumper

Standard strokes

Bore	Stroke														
	10	15	20	25	30	35	40	45	50	60	70	75	80	90	100
Ø10	●	●	●	●	●	●	●	●	●	●	●	●			
Ø15	●	●	●	●	●	●	●	●	●	●	●	●	●	●	●
Ø20	●	●	●	●	●	●	●	●	●	●	●	●	●	●	●
Ø25	●	●	●	●	●	●	●	●	●	●	●	●	●	●	●
Ø32	●	●	●	●	●	●	●	●	●	●	●	●	●	●	●

Overall dimensions Ø10

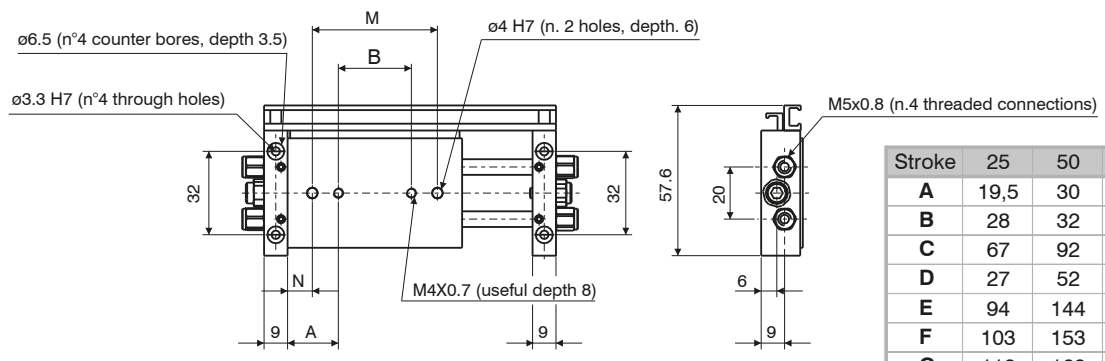
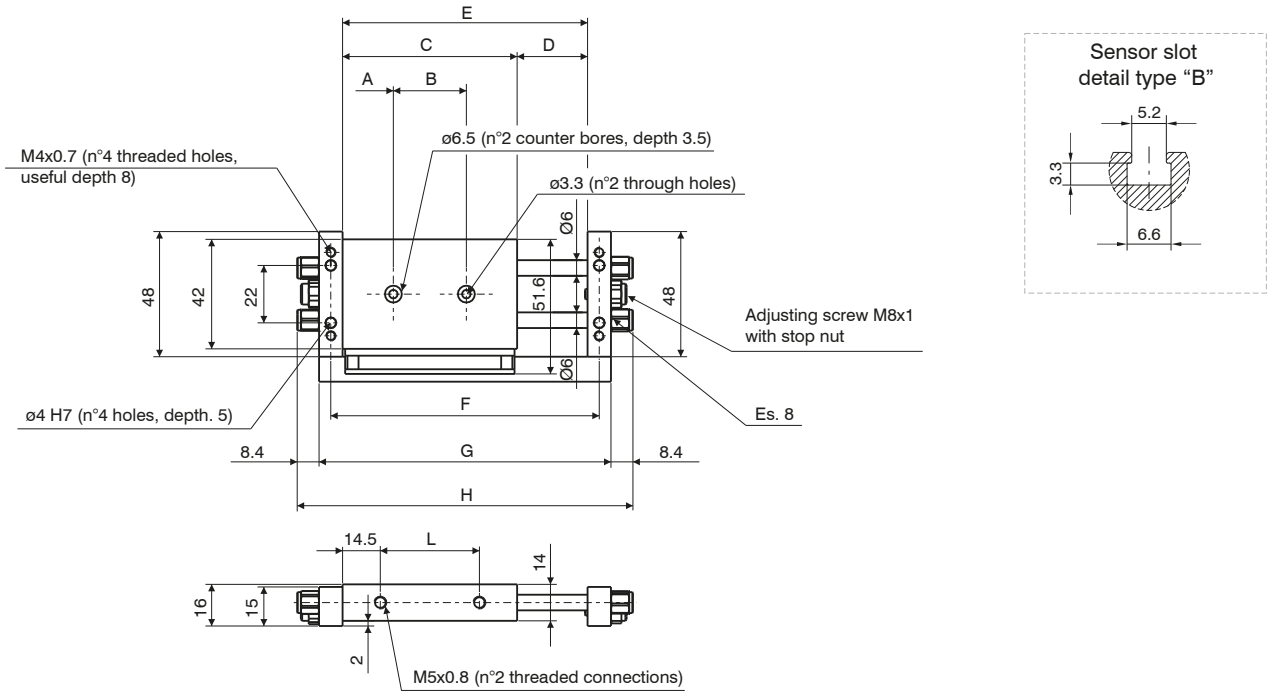

Stroke	25	50	75	100
A	19,5	30	35	35
B	28	32	47	72
C	67	92	117	142
D	27	52	77	102
E	94	144	194	244
F	103	153	203	253
G	112	162	212	262
H	129	179	229	279
L	38	63	88	113
M	48	52	67	92
N	9,5	20	25	25
Weight				
g	160	230	280	310

MOUNTING WITH FIXED PLATE

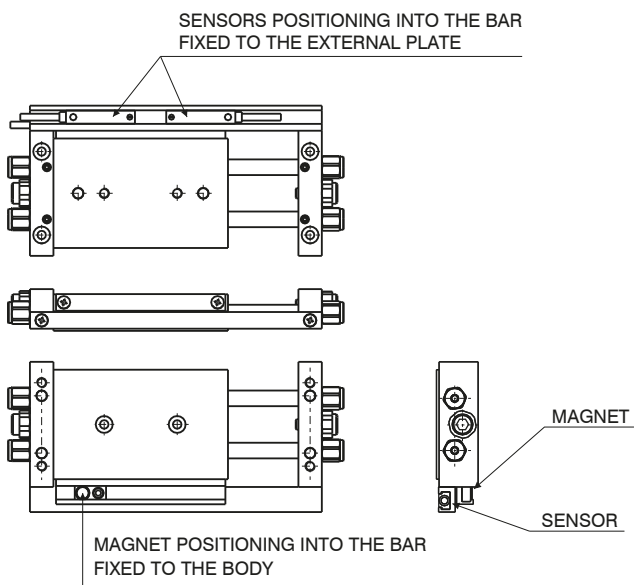

MOUNTING WITH A FIXED BODY

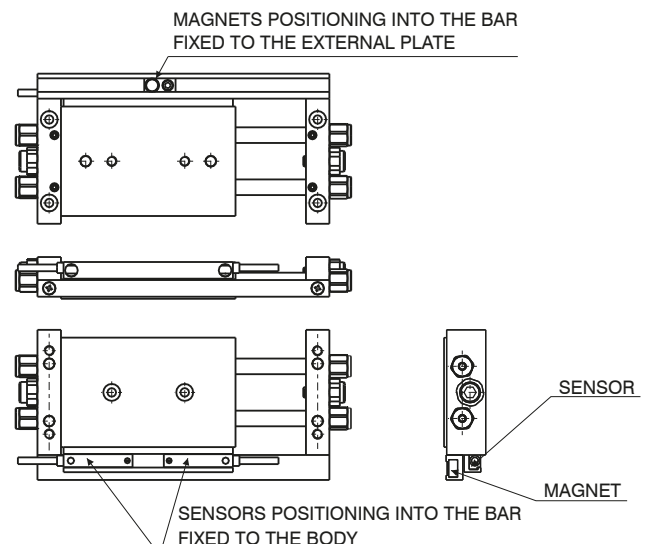

Overall dimensions Ø15

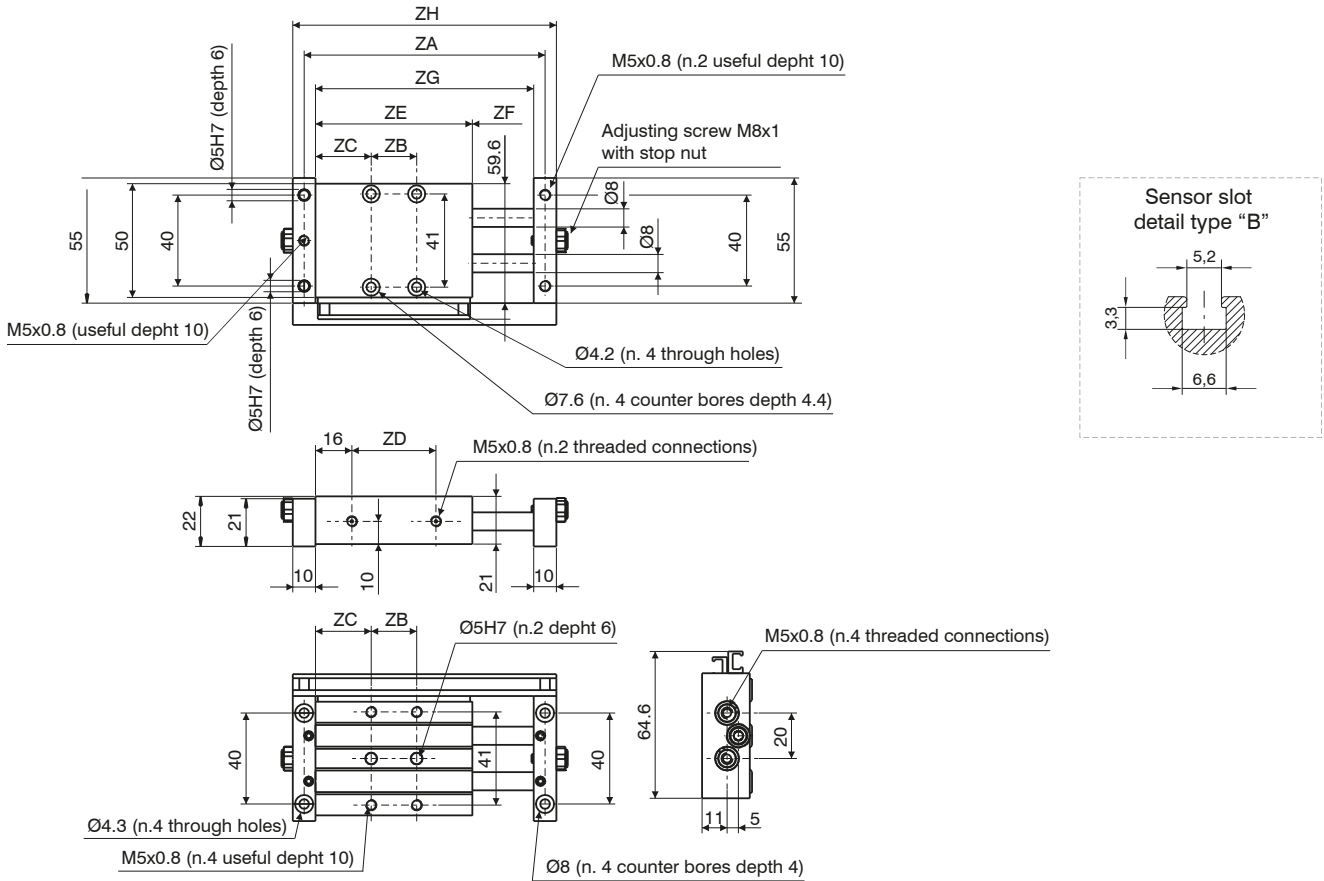

Stroke	25	50	75	100	125	150	175	200
ZA	106	156	206	256	306	356	406	456
ZB	20	45	65	90	90	90	90	90
ZC	24,5	24,5	27	27	39,5	52	64,5	77
ZD	37	62	87	112	137	162	187	212
ZE	69	94	119	144	169	194	219	244
ZF	27	52	77	102	127	152	177	202
ZG	96	146	196	246	296	346	396	446
ZH	116	166	216	266	316	366	416	466
Weight								
g	240	350	450	550	670	750	900	1000

MOUNTING WITH FIXED PLATE

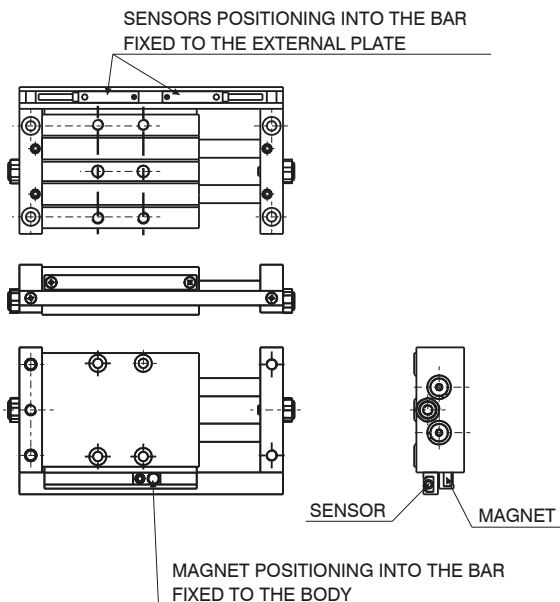

MOUNTING WITH FIXED BODY

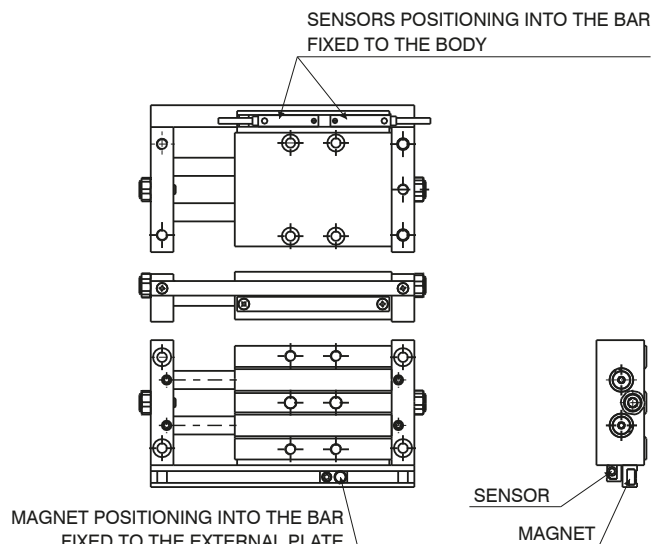

Overall dimensions Ø25

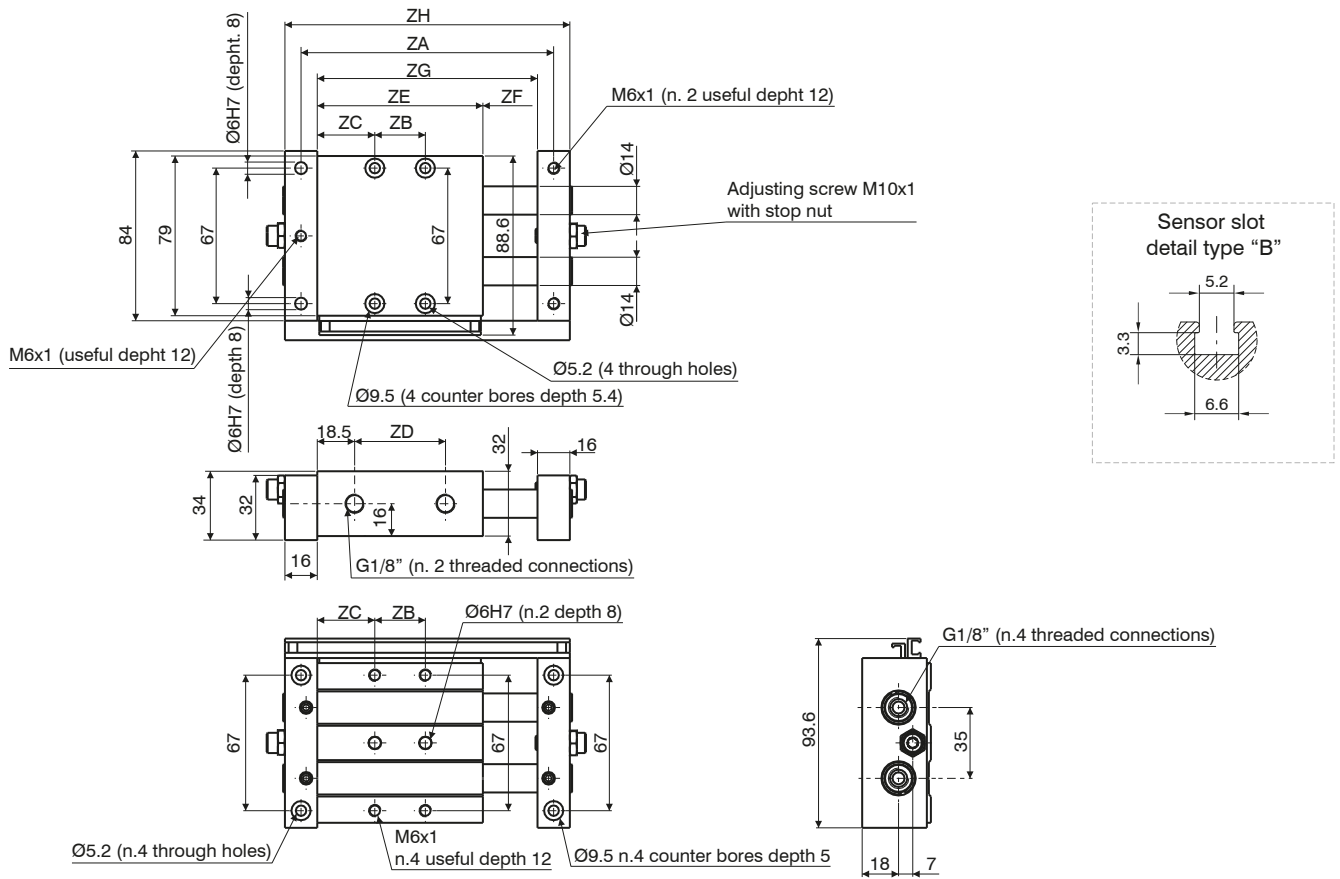

Stroke	25	50	75	100	125	150	175	200
ZA	125	175	225	275	325	375	425	475
ZB	25	45	65	90	90	90	90	90
ZC	28,5	31	33,5	33,5	46	58,5	71	83,5
ZD	45	70	95	120	145	170	195	220
ZE	82	107	132	157	182	207	232	257
ZF	27	52	77	102	127	152	177	202
ZG	109	159	209	259	309	359	409	459
ZH	141	191	241	291	341	391	441	491
Weight								
g	950	1140	1350	1600	1800	2000	2300	2500

MOUNTING WITH FIXED PLATE

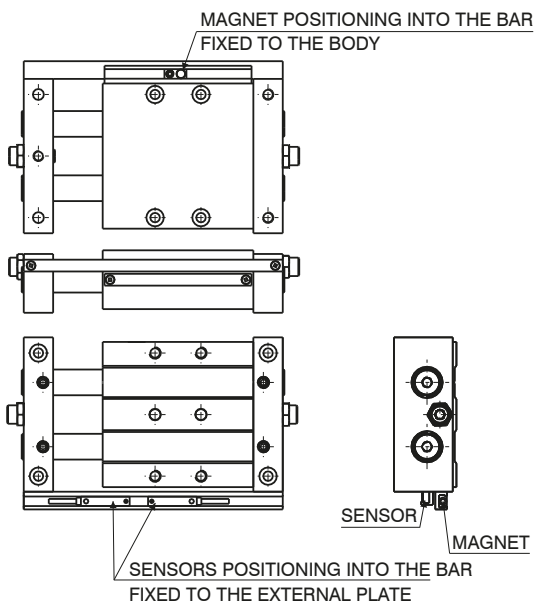

MOUNTING WITH FIXED BODY

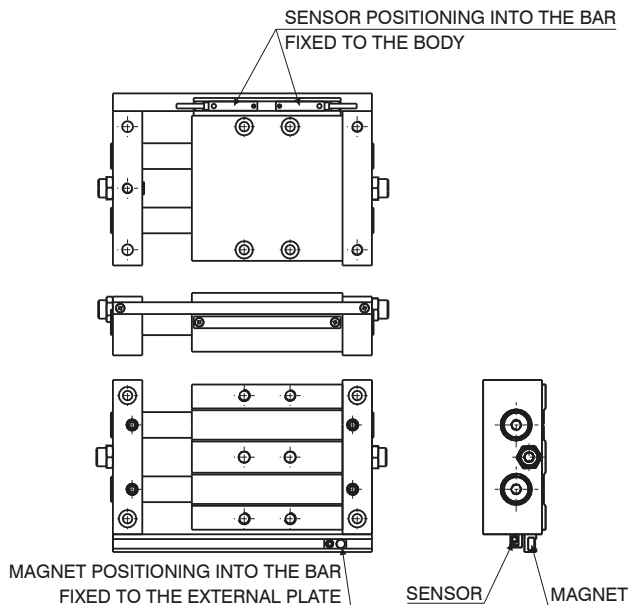

Operating conditions

Theoretical force (N)

Working pressure	Bore		
	Ø10	Ø15	Ø25
2 bar	20	41	119
3 bar	30	62	179
4 bar	40	83	239
5 bar	51	104	299
6 bar	61	124	358
7 bar	71	145	418
8 bar	81	166	478
9 bar	91	186	537
	101	207	597
	Effective area (mm ²)		

Deflection of piston rods

Applied load to body centre

Bore	Load	Deflection (mm)	
Ø10	10 N	0,07	/
Ø15	30 N	0,08	0,28
Ø25	60 N	0,02	0,08
		100	200
		Stroke	

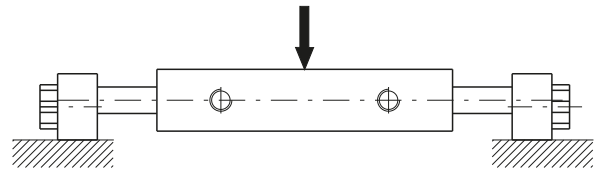

Applied load to body end

Bore	Load	Deflection (mm)			
Ø10	3 N	0,06	0,3	/	/
Ø15	5 N	0,1	0,2	0,5	1
Ø25	10 N	0,03	0,1	0,15	0,25
		50	100	150	200
		Stroke			

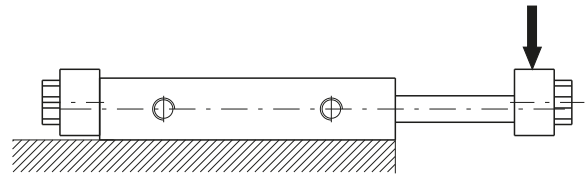

Control unit with bronze bushes

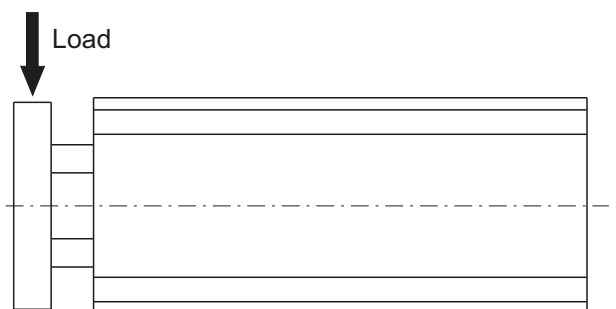
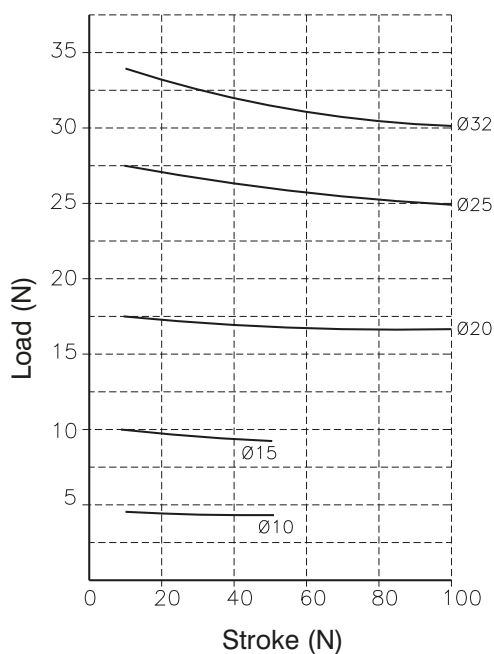

3

PNEUMATIC ACTUATION