

Functional schematic

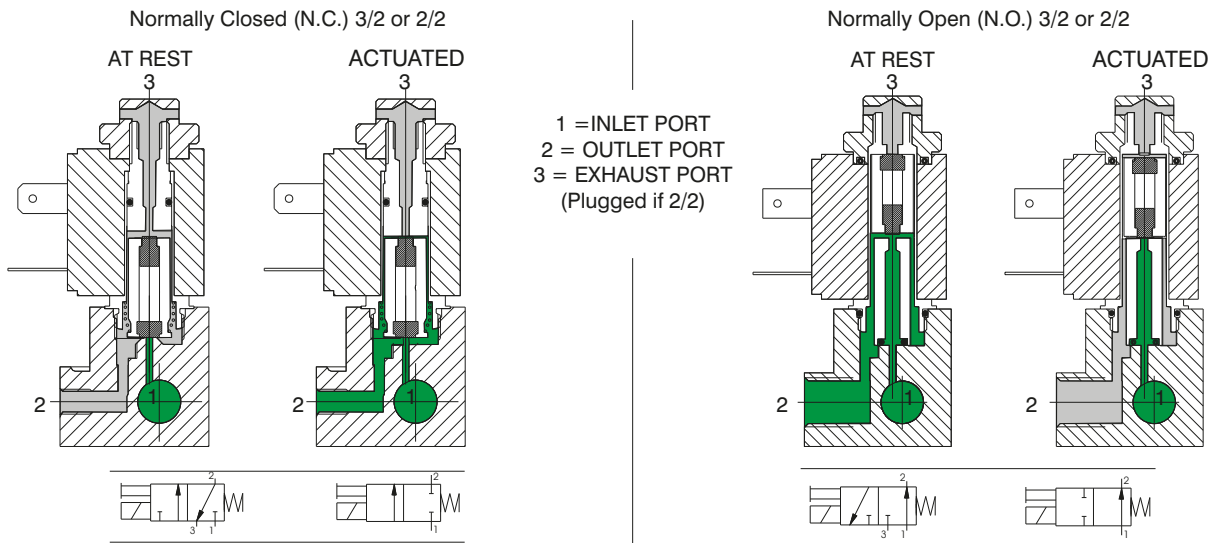

Construction characteristics

Electrical parts: Solenoids: the solenoid consist of coils having different diameter copper wire windings insulated according standards "H"; they are encased in a nylon-glass compound. All parts are corrosion resistant.

Mechanical parts: Nickel plated brass tube nitrile (NBR) stainless steel plunger (AISI 430F), stainless steel adjusted springs, viton poppet seals, tropicalized zinc alloy interface plate, nickered brass manual override, Technopolymer coil lock nut, zinc steel mounting screws. Electrical connectors are standard.

Technical characteristics

Pneumatic	Working pressure	0 - 10 bar	
	Orifice size	1,3 mm	(1,1 mm for 2 W)
	Maximum fluid temperature	50°C	
	Maximum ambient temperature	50°C	
	Maximum flow rate at 6 bar with $\eta_p = 1$	53 NI/min	(35 NI/min. for 2 W)
	Cycles/minute	700	
	Fluids	Air-Vacuum-Inert gases	
	Lubrication	Non needed	
	Life	40 to 50 million cycles	
	Electrical	Power consumption holding - D.C	5 W
Power consumption holding - A.C		8 VA	(6 VA) low consumption
Operating voltage tolerance		$\pm 10\%$	
Response time opening *		8 ms	
Response time closing *		6 ms	
Insulation of the copper wire		H	
Insulation of the coil		F	
Connector protection		IP 65	
Cable protection		DIN 43650 INDUSTRIAL FORM	

(*) "Shifting time of pneumatic directional control valves or moving parts, logic devices were measured in accordance to ISO 12238:2001, Pneumatic fluid power - Directional control valves - Measurement of shifting time"

Maintenance and replacement parts

Maintenance practices for these valves are similar to those already detailed for other products - replacement of the plunger or poppet is not advisable since the new replacement would not provide the best fit with the rest of the already used valve.

Special care should be taken that no dirt is accumulated between the working surface of fixed core and the plunger which would result in vibrations and overheating of the solenoid. In the case of microsolenoid it must be assured that the alternate current coil is not charged when the mechanical part is not mounted to avoid destruction of the coil.

The electrical connections have to be perfect, especially where low currents are used (12-24 V). Oxidation of contacts between the connector and the coil can lead to intermittent malfunctions which are difficult to trace. Oxidation of contacts due to humidity or corrosive atmosphere are one of the most common causes of false alarms. Clean the contacts with appropriate spray.

**Mechanical actuator for Normally Closed (N.C.)
Miniature solenoid valve**

Normally Closed (N.C.)

Ordering code

- 305.M1 A = G 1/8"
- 355.M1 A = M5
- 345.M1 A = Push in fitting for 4 mm tube

- 305.M1/9 A = G 1/8"
- 355.M1/9 A = M5
- 345.M1/9 A = Push in fitting for 4 mm tube

2 W
24 DC

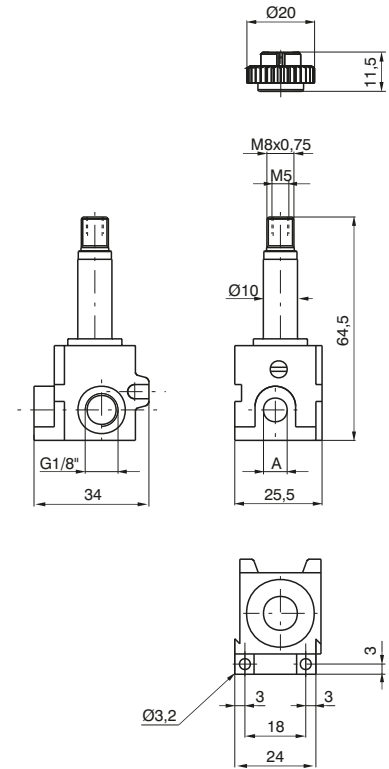

Weight 95 gr.

Normally Open (N.O.)

Ordering code

- 305.M1/1 A = G 1/8"
- 355.M1/1 A = M 5
- 345.M1/1 A = Push in fitting for 4 mm tube

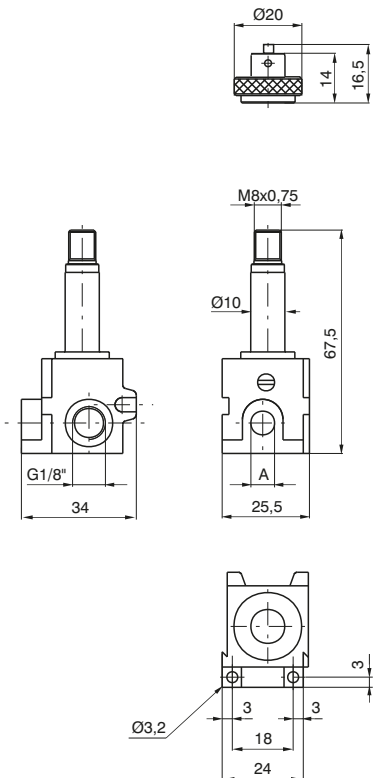

Weight 106 gr.

1
AIR DISTRIBUTION

Miniature solenoid valve

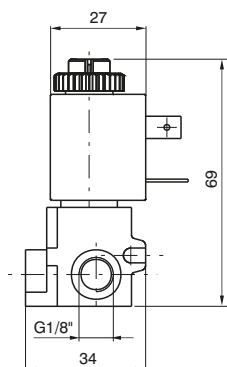

Normally Closed (N.C.)

Weight 149 gr.



Ordering code			Available voltage miniature solenoid	
G 1/8"	M5	TUBE Ø4 mm		
305.M4	355.M4	345.M4	12 D.C.	Direct current
305.M5	355.M5	345.M5	24 D.C.	
305.M6	355.M6	345.M6	48 D.C.	
305.M9	355.M9	345.M9	24 D.C. (2 Watt)	
305.M17	355.M17	345.M17	24/50	Alternating current 50 Hz
305.M21	355.M21	345.M21	48/50	
305.M22	355.M22	345.M22	110/50	
305.M24	355.M24	345.M24	230/50	
305.M37	355.M37	345.M37	24/60	Alternating current 60 Hz
305.M39	355.M39	345.M39	110/60	
305.M41	355.M41	345.M41	230/60	
305.M56	355.M56	345.M56	24/50-60	Alternating current 50/60 Hz
305.M57	355.M57	345.M57	110/50-60	
305.M58	355.M58	345.M58	230/50-60	
305.M66	355.M66	345.M66	24/50-60	Alternating current low consumption 50/60 Hz
305.M67	355.M67	345.M67	110/50-60	
305.M68	355.M68	345.M68	230/50-60	

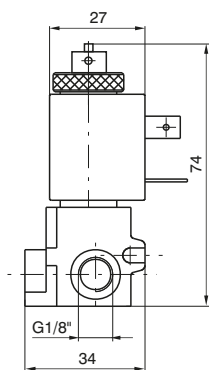

Normally Open (N.O.)

Weight 165 gr.

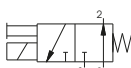

Ordering code			Available voltages miniature solenoid	
G 1/8"	M5	TUBE Ø4 mm		
305.M10/1	355.M10/1	345.M10/1	24 D.C. (8 Watt)	Direct current
305.M17/1	355.M17/1	345.M17/1	24/50	Alternating current 50 Hz
305.M21/1	355.M21/1	345.M21/1	48/50	
305.M22/1	355.M22/1	345.M22/1	110/50	
305.M24/1	355.M24/1	345.M24/1	230/50	
305.M37/1	355.M37/1	345.M37/1	24/60	Alternating current 60 Hz
305.M39/1	355.M39/1	345.M39/1	110/60	
305.M41/1	355.M41/1	345.M41/1	230/60	
305.M56/1	355.M56/1	345.M56/1	24/50-60	Alternating current 50/60 Hz
305.M57/1	355.M57/1	345.M57/1	110/50-60	
305.M58/1	355.M58/1	345.M58/1	230/50-60	

1
AIR DISTRIBUTION

Coil



Weight 54 gr.

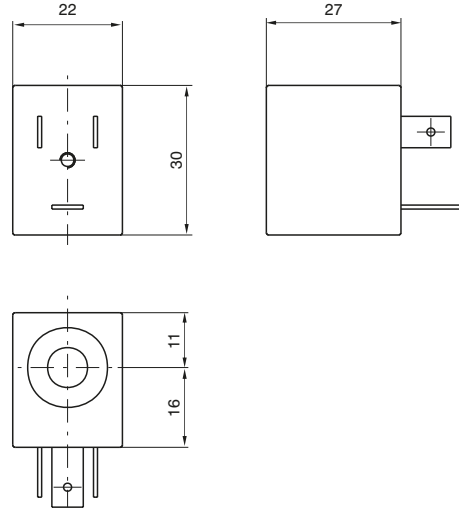

1
AIR DISTRIBUTION

Ordering code		Available voltages Coil
N.C.	N.O.	
MB4 MB5 MB6 MB9	MB10/1	12 D.C. 24 D.C. 48 D.C. 24 D.C. (2 Watt) 24 D.C. (8 Watt) Direct current
MB17 MB21 MB22 MB24	MB17/1 MB21/1 MB22/1 MB24/1	24/50 48/50 110/50 230/50 Alternating current 50 Hz
MB37 MB39 MB41	MB37/1 MB39/1 MB41/1	24/60 110/60 230/60 Alternating current 60 Hz
MB56 MB57 MB58	MB56/1 MB57/1 MB58/1	24/50-60 110/50-60 230/50-60 Alternating current 50/60 Hz
MB66 MB67 MB68	/	24/50-60 110/50-60 230/50-60 Alternating current (low consumption) 50/60 Hz

Electrical connector

Ordering code

305.11.00 Normal

305.11.0 L with Led
 1 = 24 V D.C. / A.C.
 2 = 110 V 50/60 Hz
 3 = 230 V 50/60 Hz

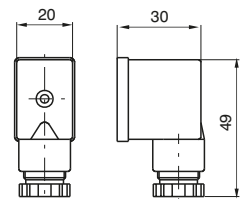

Weight 19 gr.

BISTABLE

General

The most interesting aspects of this bi-stable miniature solenoid valve operating with D.C. only, is that it can be commuted with a simple electric impulse and stay commuted till an inverted polarity impulse deactivates it. It means that the valve is not automatically deactivated if current fail as happens with normal solenoid valves.

The applications differ but are all based on above mentioned feature.

The internal construction is relatively special. The fix plunger is equipped with a permanent magnet that hold or release the mobile plunger according to the magnetic field generated by the coil.

A specific coil is used for this application and it cannot be replaced by the standard ones.

Ordering code is **MBB5**.

Miniature solenoid valve for distributors and bases

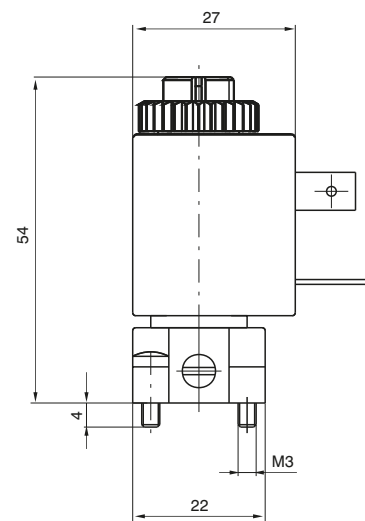

Ordering code

M5/B

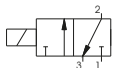

Miniature solenoid valve with inseries mounting base

Ordering code

305.M5/B = G 1/8"

355.M5/B = M5

345.M5/B = Fitting for 4 mm tube

