



Series 2600

General

They have been designed to be easily assembled into groups or manifolds.
The 2600 series comprises a range of products classified according to the body size of 26mm divided into 3 types "LINE", "FLAT" and "VDMA".
Is not included the integral electrical connection

AIR DISTRIBUTION

Construction characteristics

Central body	Extruded aluminium bar with chemical nickel treatment and PTFE (polytetrafluorethylene)
Connection plates	Die-cast aluminium
Operators	Technopolymer
Spool seals	Oil resistant nitrile rubber - HNBR
Spools	Aluminium 2011
Springs	AISI 302 stainless steel
Pistons	Technopolymer
Piston seals	Oil resistant nitrile rubber - NBR

Ordering codes for miniature solenoid valves

The 15 mm. miniature solenoid valve with 1,1 mm. orifice has been selected for piloting this series of valves (see Series 300). This results in low response times and reduced power consumption.
The valve can be supplied with the coil upward or downward (multipolar connections) depending on the application.
Codes are as follows:

Coil upward code

- 01 = miniature solenoid 12 VDC
- 02 = miniature solenoid 24 VDC
- 05 = miniature solenoid 24 VAC
- 06 = miniature solenoid 110 VAC
- 07 = miniature sol. 230 VAC
- 08 = miniature sol. 24 VDC 1W
- 09 = miniature sol. 24 VDC Earth faston

Coil downward code

- 11 = miniature solenoid 12 VDC
- 12 = miniature solenoid 24 VDC
- 15 = miniature solenoid 24 VAC
- 16 = miniature solenoid 110 VAC
- 17 = miniature sol. 230 VAC
- 18 = miniature sol. 24 VDC 1W Downward
- 19 = miniature sol. 24 VDC Earth faston Downward

Miniature solenoid c  homologated are available (see Series 300).

Use and maintenance

The average life of the solenoid valve exceeds 50.000.000 cycles when used under optimum conditions.
Adequate lubrication reduces seals wear, just as proper filtering of supply air prevents the build-up of dirt that can cause malfunction.
Ensure the valve is used within our recommended criteria for pressure and temperature.
In dirty or dusty environments, the exhaust ports should be protected.
A seal kit including the spool is available for overhauling the valve. This operation does not require a skilled worker, although a particular care should be taken when reassembling the valve.

Pneumatic - Spring

Coding: 261 **A**.52.00.19

Operational characteristics	
Fluid	Filtered air. No lubrication needed, if applied it shall be continuous
Max working pressure (bar)	10
Temperature °C	-5 ÷ +50
Flow rate at 6 bar with Δp=1 (NI/min)	1500
Orifice size (mm)	9
Pilot ports size	G1/8"

WORKING PORTS SIZE	
A	1 = G3/8"
	5 = G1/4"
	8 = Quick fitting tube Ø10

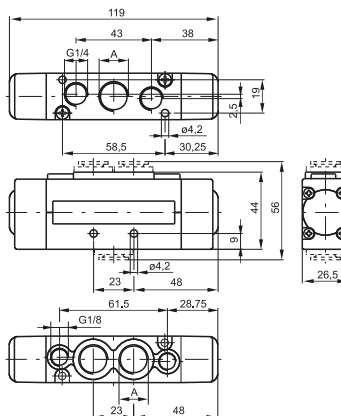

Weight 235 g
Minimum piloting pressure 2 bar

For dimension "A" see ordering code

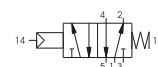

1
AIR DISTRIBUTION

Pneumatic - Differential

Coding: 261 **A**.52.00.16

Operational characteristics	
Fluid	Filtered air. No lubrication needed, if applied it shall be continuous
Max working pressure (bar)	10
Temperature °C	-5 ÷ +50
Flow rate at 6 bar with Δp=1 (NI/min)	1500
Orifice size (mm)	9
Pilot ports size	G1/8"

WORKING PORTS SIZE	
A	1 = G3/8"
	5 = G1/4"
	8 = Quick fitting tube Ø10

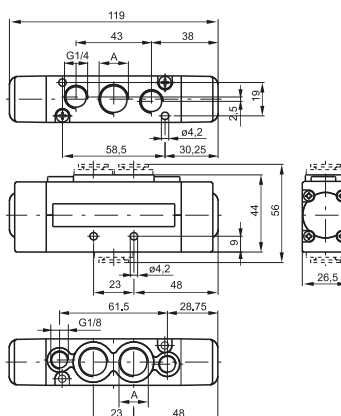

Weight 235 g
Minimum piloting pressure 2 bar

For dimension "A" see ordering code

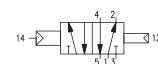



Pneumatic - Differential (External)

Coding: 261(A).52.00.17

Operational characteristics	
Fluid	Filtered air. No lubrication needed, if applied it shall be continuous
Max working pressure (bar)	10
Temperature °C	-5 ÷ +50
Flow rate at 6 bar with $\Delta p=1$ (NI/min)	1500
Orifice size (mm)	9
Pilot ports size	G1/8"

WORKING PORTS SIZE	
1	= G3/8"
5	= G1/4"
8	= Quick fitting tube $\varnothing 10$

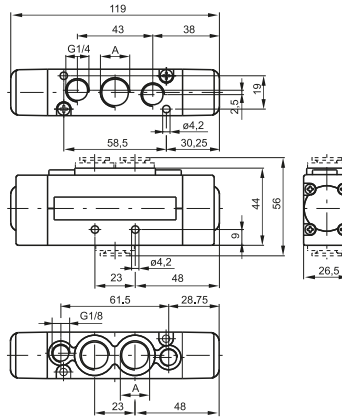

Weight 235 g
Minimum piloting pressure 2 bar

For dimension "A" see ordering code

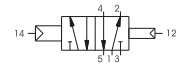

Pneumatic - Pneumatic

Coding: 261(A).52.00.18

Operational characteristics	
Fluid	Filtered air. No lubrication needed, if applied it shall be continuous
Max working pressure (bar)	10
Temperature °C	-5 ÷ +50
Flow rate at 6 bar with $\Delta p=1$ (NI/min)	1500
Orifice size (mm)	9
Pilot ports size	G1/8"

WORKING PORTS SIZE	
1	= G3/8"
5	= G1/4"
8	= Quick fitting tube $\varnothing 10$

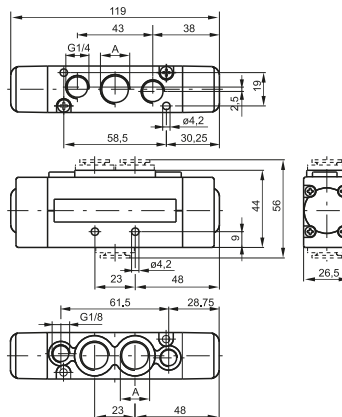

Weight 235 g
Minimum piloting pressure 1,5 bar

For dimension "A" see ordering code



AIR DISTRIBUTION

1

Solenoid-Spring/Differential

Coding: 261 **A**.52.00. **V**. **T**

Operational characteristics	
Fluid	Filtered air. No lubrication needed, if applied it shall be continuous
Max working pressure (bar)	10
Temperature °C	-5 ÷ +50
Flow rate at 6 bar with Δp=1 (NI/min)	1500
Orifice size (mm)	9

WORKING PORTS SIZE	
A	1 = G3/8"
	5 = G1/4"
	8 = Quick fitting tube Ø10
VERSION	
	39 = Solenoid - Spring
	29 = Solenoid external-Spring
	36 = Solenoid-Differential
V	37 = Solenoid-Differential external
	26 = Solenoid external-Differential
	27 = Solenoid external-Differential external
VOLTAGE	
	01 = 12V DC
	02 = 24V DC
	05 = 24V AC
	06 = 110V AC
	07 = 230 V AC
	08 = 24V DC 1W
T	09 = 24V DC downward
	11 = 12V DC downward
	12 = 24V DC downward
	15 = 24V AC downward
	16 = 110V AC downward
	17 = 230 V AC downward
	18 = 24V DC 1W downward
	19 = 24V DC Earth faston downward

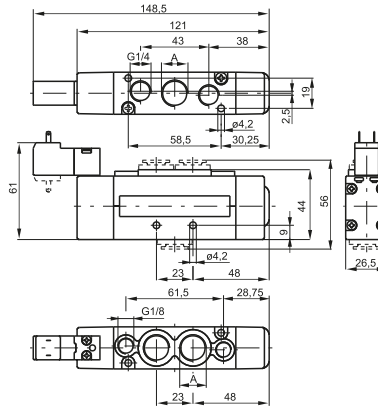

Weight 275 g
Minimum piloting pressure 2 bar

For dimension "A" see ordering code

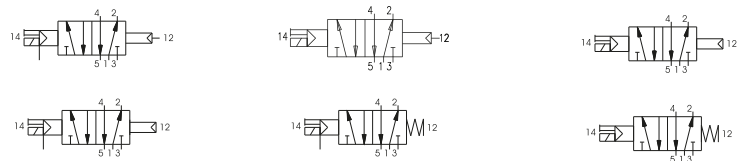

1
AIR DISTRIBUTION

Solenoid - Solenoid

Coding: 261 **A**.52.00. **V**. **T**

Operational characteristics	
Fluid	Filtered air. No lubrication needed, if applied it shall be continuous
Max working pressure (bar)	10
Temperature °C	-5 ÷ +50
Flow rate at 6 bar with Δp=1 (NI/min)	1500
Orifice size (mm)	9

WORKING PORTS SIZE	
A	1 = G3/8"
	5 = G1/4"
	8 = Quick fitting tube Ø10
VERSION	
V	35 = Solenoid-Solenoid
	24 = Solenoid external-Solenoid external
VOLTAGE	
	01 = 12V DC
	02 = 24V DC
	05 = 24V AC
	06 = 110V AC
	07 = 230 V AC
	08 = 24V DC 1W
T	09 = 24V DC downward
	11 = 12V DC downward
	12 = 24V DC downward
	15 = 24V AC downward
	16 = 110V AC downward
	17 = 230 V AC downward
	18 = 24V DC 1W downward
	19 = 24V DC Earth faston downward

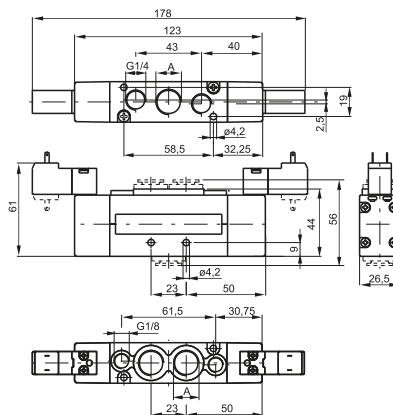

Weight 295 g
Minimum piloting pressure 1,5 bar

For dimension "A" see ordering code

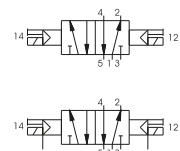

Pneumatic - Pneumatic 5 ways 3 connections

Coding: 261^A.53.^F.18

Operational characteristics	
Fluid	Filtered air. No lubrication needed, if applied it shall be continuous
Max working pressure (bar)	10
Temperature °C	-5 ÷ +50
Flow rate at 6 bar with Δp=1 (Nl/min)	1350
Orifice size (mm)	9
Pilot ports size	M5

A	WORKING PORTS SIZE
	1 = G3/8"
	5 = G1/4"
F	FUNCTION
	31 = Closed centres
	32 = Open centres
	33 = Pressured centres

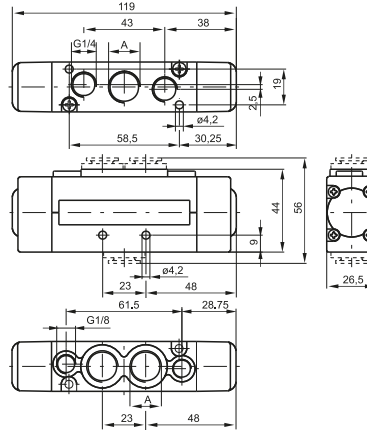

For dimension "A" see ordering code

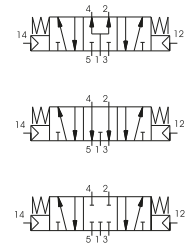

Weight 245 g
 Minimum piloting pressure 3 bar

Solenoid - Solenoid 5 ways 3 connections

Coding: 261^A.53.^{F.V}.^T

Operational characteristics	
Fluid	Filtered air. No lubrication needed, if applied it shall be continuous
Max working pressure (bar)	10
Temperature °C	-5 ÷ +50
Flow rate at 6 bar with Δp=1 (Nl/min)	1350
Orifice size (mm)	9

A	WORKING PORTS SIZE
	1 = G3/8"
	5 = G1/4"
F	FUNCTION
	31 = Closed centres
	32 = Open centres
	33 = Pressured centres
V	VERSION
	24 = Solenoid external-Solenoid external
	35 = Solenoid-Solenoid
T	VOLTAGE
	01 = 12V DC
	02 = 24V DC
	05 = 24V AC
	06 = 110V AC
	07 = 230 V AC
	08 = 24V DC 1W
	09 = 24V DC downward
	11 = 12V DC downward
	12 = 24V DC downward
	15 = 24V AC downward
	16 = 110V AC downward
17 = 230 V AC downward	
18 = 24V DC 1W downward	
19 = 24V DC Earth faston downward	

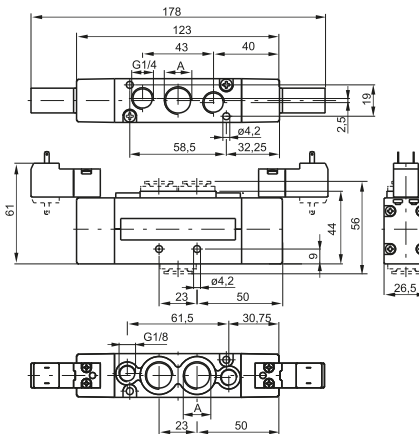

For dimension "A" see ordering code

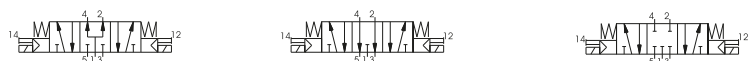

Weight 245 g
 Minimum piloting pressure 3 bar

Pneumatic - Spring

Coding: 263 **A**.52.00.19

Operational characteristics	
Fluid	Filtered air. No lubrication needed, if applied it shall be continuous
Max working pressure (bar)	10
Temperature °C	-5 ÷ +50
Flow rate at 6 bar with Δp=1 (NI/min)	1500
Orifice size (mm)	9
Pilot ports size	M5

WORKING PORTS SIZE	
A	1 = G3/8"
	5 = G1/4"
	8 = Quick fitting tube Ø10



Weight 185 g
Minimum piloting pressure 2 bar

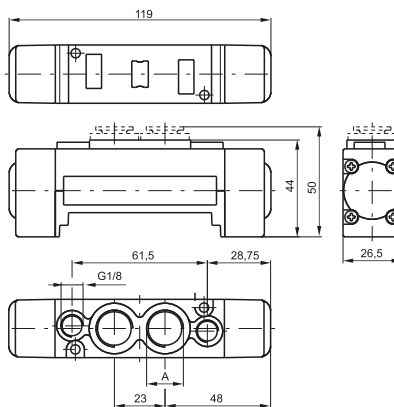

For dimension "A" see ordering code

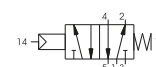

Pneumatic - Differential

Coding: 263 **A**.52.00.16

Operational characteristics	
Fluid	Filtered air. No lubrication needed, if applied it shall be continuous
Max working pressure (bar)	10
Temperature °C	-5 ÷ +50
Flow rate at 6 bar with Δp=1 (NI/min)	1500
Orifice size (mm)	9
Pilot ports size	M5

WORKING PORTS SIZE	
A	1 = G3/8"
	5 = G1/4"
	8 = Quick fitting tube Ø10



Weight 185 g
Minimum piloting pressure 2 bar

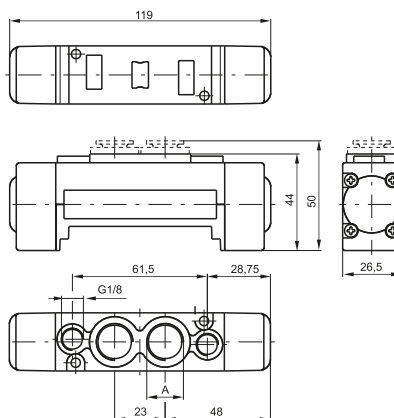

For dimension "A" see ordering code

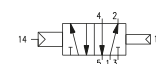

Pneumatic - Differential (External)

Coding: 263 **A**.52.00.17

Operational characteristics	
Fluid	Filtered air. No lubrication needed, if applied it shall be continuous
Max working pressure (bar)	10
Temperature °C	-5 ÷ +50
Flow rate at 6 bar with Δp=1 (NI/min)	1500
Orifice size (mm)	9
Pilot ports size	M5

WORKING PORTS SIZE	
A	1 = G3/8"
	5 = G1/4"
	8 = Quick fitting tube Ø10



Weight 185 g
Minimum piloting pressure 2 bar

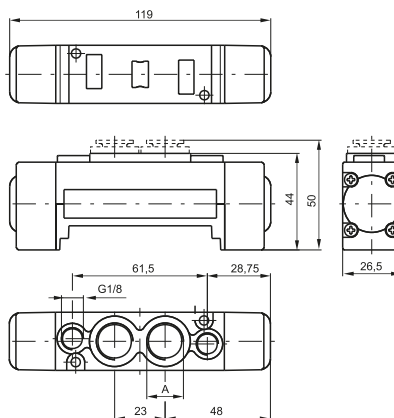

For dimension "A" see ordering code





Spool valves and solenoid valves
Series 2600 - Size 26mm FLAT

Pneumatic - Pneumatic

Coding: 263A.52.00.18

Operational characteristics

Fluid	Filtered air. No lubrication needed, if applied it shall be continuous
Max working pressure (bar)	10
Temperature °C	-5 ÷ +50
Flow rate at 6 bar with Δp=1 (NI/min)	1500
Orifice size (mm)	9
Pilot ports size	M5

WORKING PORTS SIZE	
1	= G3/8"
5	= G1/4"
8	= Quick fitting tube Ø10

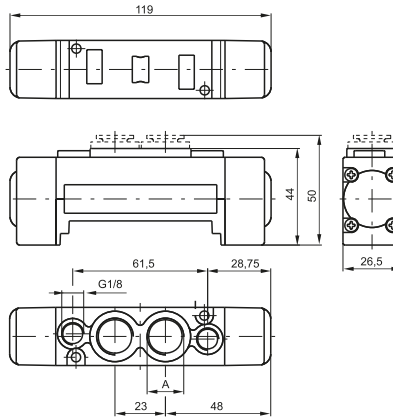

For dimension "A" see ordering code

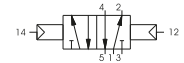

Weight 185 g
 Minimum piloting pressure 1,5 bar

1
AIR DISTRIBUTION

Solenoid-Spring / Differential

Coding: 263A.52.00.V.T

Operational characteristics	
Fluid	Filtered air. No lubrication needed, if applied it shall be continuous
Max working pressure (bar)	10
Temperature °C	-5 ÷ +50
Flow rate at 6 bar with Δp=1 (NI/min)	1500
Orifice size (mm)	9

WORKING PORTS SIZE	
A	1 = G3/8"
	5 = G1/4"
	8 = Quick fitting tube Ø10
VERSION	
	39 = Solenoid - Spring
	29 = Solenoid external-Spring
	36 = Solenoid-Differential
V	37 = Solenoid-Differential external
	26 = Solenoid external-Differential
	27 = Solenoid external-Differential external
VOLTAGE	
	01 = 12V DC
	02 = 24V DC
	05 = 24V AC
	06 = 110V AC
	07 = 230 V AC
	08 = 24V DC 1W
T	09 = 24V DC downward
	11 = 12V DC downward
	12 = 24V DC downward
	15 = 24V AC downward
	16 = 110V AC downward
	17 = 230 V AC downward
	18 = 24V DC 1W downward
	19 = 24V DC Earth faston downward

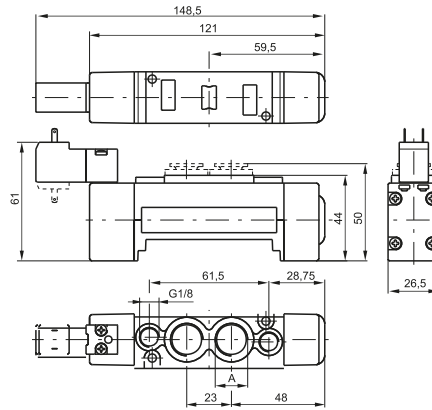

For dimension "A" see ordering code

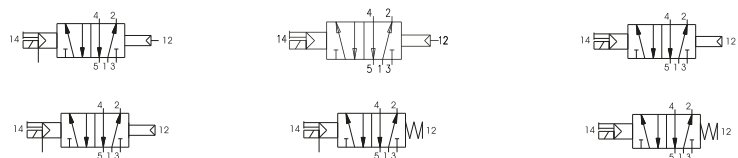

Weight 220 g
Minimum piloting pressure 2 bar

1
AIR DISTRIBUTION

Solenoid - Solenoid

Coding: 263A.52.00.V.T

Operational characteristics	
Fluid	Filtered air. No lubrication needed, if applied it shall be continuous
Max working pressure (bar)	10
Temperature °C	-5 ÷ +50
Flow rate at 6 bar with Δp=1 (NI/min)	1500
Orifice size (mm)	9

WORKING PORTS SIZE	
A	1 = G3/8"
	5 = G1/4"
	8 = Quick fitting tube Ø10
VERSION	
V	35 = Solenoid-Solenoid
	24 = Solenoid external-Solenoid external
VOLTAGE	
	01 = 12V DC
	02 = 24V DC
	05 = 24V AC
	06 = 110V AC
	07 = 230 V AC
	08 = 24V DC 1W
T	09 = 24V DC downward
	11 = 12V DC downward
	12 = 24V DC downward
	15 = 24V AC downward
	16 = 110V AC downward
	17 = 230 V AC downward
	18 = 24V DC 1W downward
	19 = 24V DC Earth faston downward

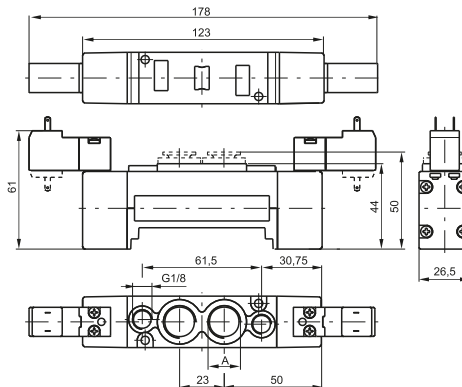

For dimension "A" see ordering code

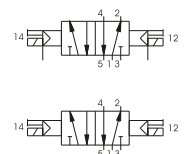

Weight 250 g
Minimum piloting pressure 1,5 bar



Spool valves and solenoid valves Series 2600 - Size 26mm FLAT

Pneumatic - Pneumatic 5 ways 3 connections

Coding: 263A.53.F.18

Operational characteristics	
Fluid	Filtered air. No lubrication needed, if applied it shall be continuous
Max working pressure (bar)	10
Temperature °C	-5 ÷ +50
Flow rate at 6 bar with Δp=1 (NI/min)	1350
Orifice size (mm)	9
Pilot ports size	M5

WORKING PORTS SIZE	
A	1 = G3/8"
	5 = G1/4"
	8 = Quick fitting tube Ø10
FUNCTION	
F	31 = Closed centres
	32 = Open centres
	33 = Pressured centres

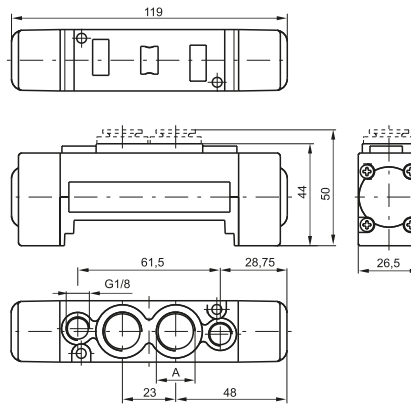

For dimension "A" see ordering code

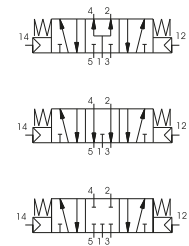

Weight 195 g
Minimum piloting pressure 3 bar

Solenoid - Solenoid 5 ways 3 connections

Coding: 263A.53.F.V.T

Operational characteristics	
Fluid	Filtered air. No lubrication needed, if applied it shall be continuous
Max working pressure (bar)	10
Temperature °C	-5 ÷ +50
Flow rate at 6 bar with Δp=1 (NI/min)	1350
Orifice size (mm)	9

WORKING PORTS SIZE	
A	1 = G3/8"
	5 = G1/4"
	8 = Quick fitting tube Ø10
FUNCTION	
F	31 = Closed centres
	32 = Open centres
	33 = Pressured centres
VERSION	
V	24 = Solenoid external-Solenoid external
	35 = Solenoid-Solenoid
VOLTAGE	
T	01 = 12V DC
	02 = 24V DC
	05 = 24V AC
	06 = 110V AC
	07 = 230 V AC
	08 = 24V DC 1W
	09 = 24V DC downward
	11 = 12V DC downward
	12 = 24V DC downward
	15 = 24V AC downward
	16 = 110V AC downward
	17 = 230 V AC downward
	18 = 24V DC 1W downward
	19 = 24V DC Earth faston downward

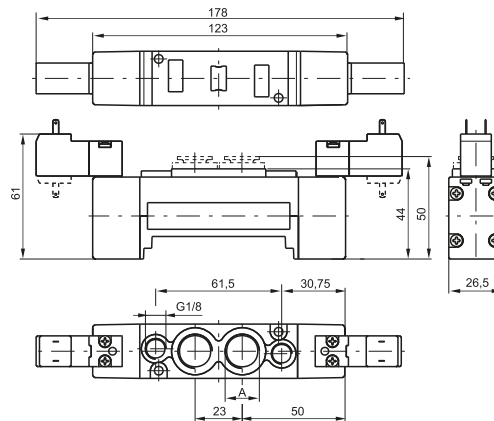

For dimension "A" see ordering code

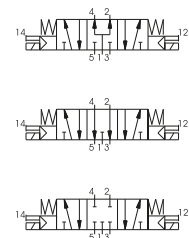

Weight 270 g
Minimum piloting pressure 3 bar

1 AIR DISTRIBUTION

▶ **Modular base**

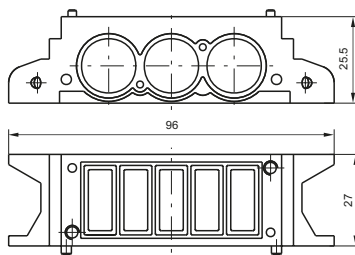

Coding: 2630.01

Weight 80 g

▶ **Inlet base**

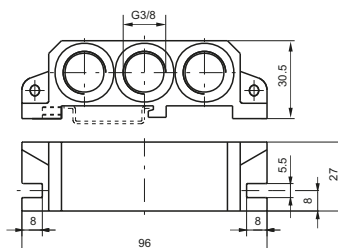

Coding: 2630.02

Weight 80 g

2630.02

VERSION	
✓	02 = Right
	03 = Left

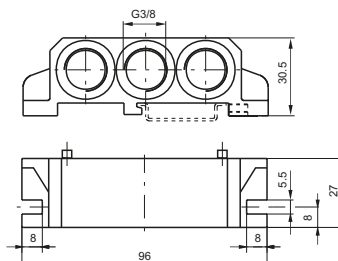

Weight 100 g

2630.03

▶ **Intermediate air intake**

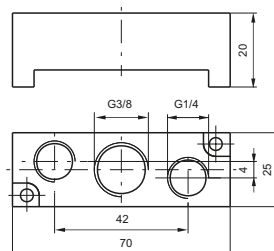

Coding: 2630.10

Weight 60 g
to be assembled instead of a valve

▶ **Closing plate**

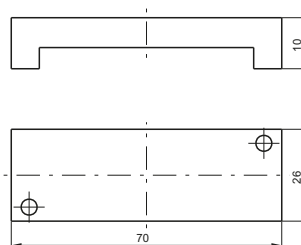

Coding: 2630.00

Weight 20 g

▶ **Diaphragm plug**



Coding: 2630.17

Weight 5 g



1
AIR DISTRIBUTION

Pneumatic - Spring

Coding: 2645.52.00.19

Operational characteristics	
Fluid	Filtered air. No lubrication needed, if applied it shall be continuous
Max working pressure (bar)	10
Temperature °C	-5 ÷ +50
Flow rate at 6 bar with $\Delta p=1$ (NI/min)	1100
Orifice size (mm)	7.5

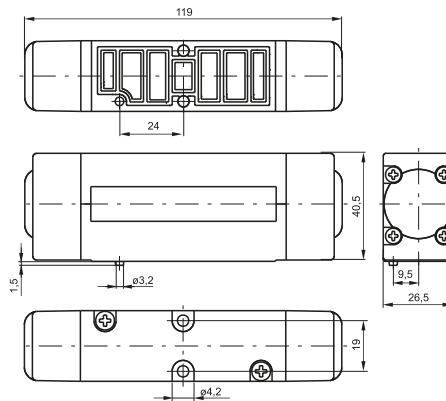

Weight 235 g
Minimum piloting pressure 2 bar

Pneumatic - Differential

Coding: 2645.52.00.16

Operational characteristics	
Fluid	Filtered air. No lubrication needed, if applied it shall be continuous
Max working pressure (bar)	10
Temperature °C	-5 ÷ +50
Flow rate at 6 bar with $\Delta p=1$ (NI/min)	1100
Orifice size (mm)	7.5

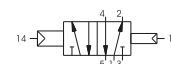
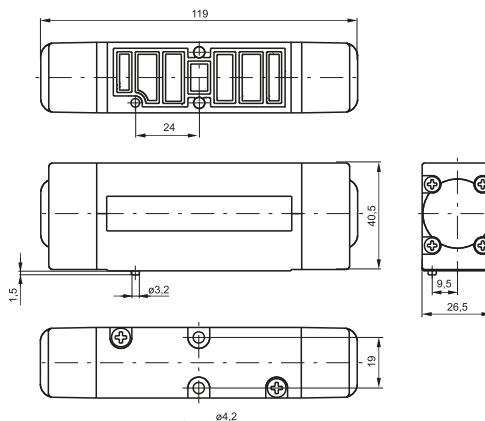

Weight 235 g
Minimum piloting pressure 2 bar

Pneumatic - Differential (External)

Coding: 2645.52.00.17

Operational characteristics	
Fluid	Filtered air. No lubrication needed, if applied it shall be continuous
Max working pressure (bar)	10
Temperature °C	-5 ÷ +50
Flow rate at 6 bar with $\Delta p=1$ (NI/min)	1100
Orifice size (mm)	7.5

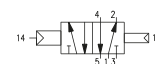
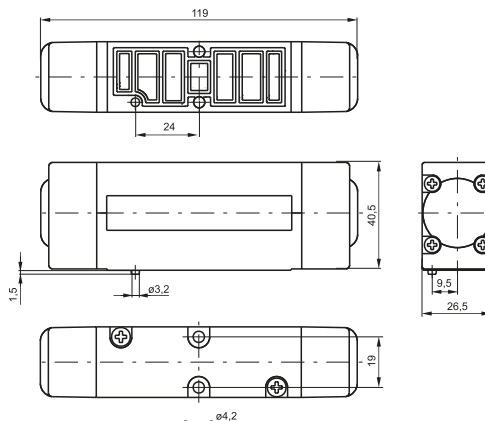

Weight 235 g
Minimum piloting pressure 2 bar

Pneumatic - Pneumatic

Coding: 2645.52.00.18

Operational characteristics	
Fluid	Filtered air. No lubrication needed, if applied it shall be continuous
Max working pressure (bar)	10
Temperature °C	-5 ± +50
Flow rate at 6 bar with $\Delta p=1$ (l/min)	1100
Orifice size (mm)	7.5



Weight 255 g
Minimum piloting pressure 1,5 bar

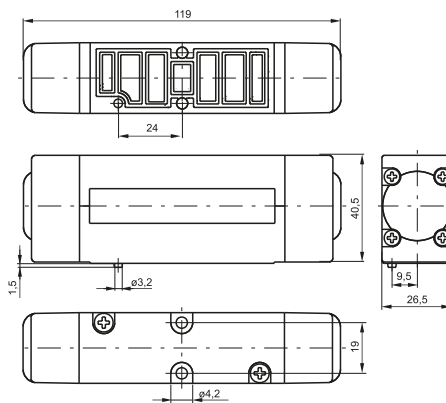

1
AIR DISTRIBUTION



AIR DISTRIBUTION

Solenoid-Spring / Differential

Coding: 264^C.52.00.^V.^T

Operational characteristics	
Fluid	Filtered air. No lubrication needed, if applied it shall be continuous
Max working pressure (bar)	10
Temperature °C	-5 ÷ +50
Flow rate at 6 bar with Δp=1 (NI/min)	1100
Orifice size (mm)	7.5

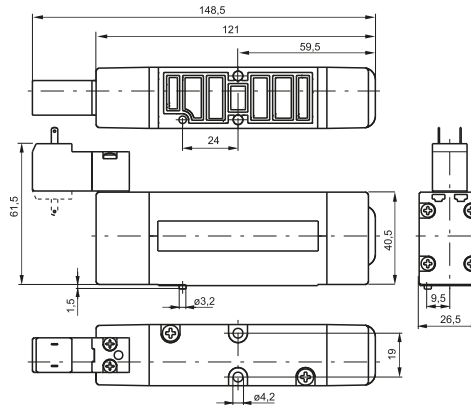

C	TYPE ELECTROPILOT EXHAUST
	1 = on base (only for self feeding valves) 5 = on pilot (for all version)
V	VERSION
	39 = Solenoid - Spring
	29 = Solenoid external-Spring
	36 = Solenoid-Differential
	37 = Solenoid-Differential external
T	VOLTAGE
	01 = 12V DC
	02 = 24V DC
	05 = 24V AC
	06 = 110V AC
T	07 = 230 V AC
	08 = 24V DC 1W
	09 = 24V DC downward
	11 = 12V DC downward
	12 = 24V DC downward
	15 = 24V AC downward
	16 = 110V AC downward
	17 = 230 V AC downward
	18 = 24V DC 1W downward
	19 = 24V DC Earth faston downward

Weight 270 g
 Minimum piloting pressure 2 bar

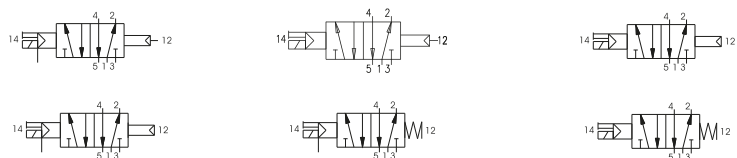

Solenoid - Solenoid

Coding: 264^C.52.00.^V.^T

Operational characteristics	
Fluid	Filtered air. No lubrication needed, if applied it shall be continuous
Max working pressure (bar)	10
Temperature °C	-5 ÷ +50
Flow rate at 6 bar with Δp=1 (NI/min)	1100
Orifice size (mm)	7.5

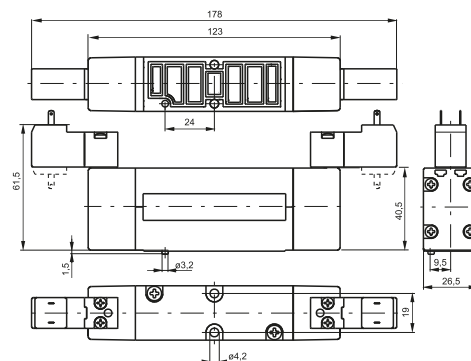

C	TYPE ELECTROPILOT EXHAUST
	1 = on base (only for self feeding valves) 5 = on pilot (for all version)
V	VERSION
	24 = Solenoid external-Solenoid external
	35 = Solenoid-Solenoid
T	VOLTAGE
	01 = 12V DC
	02 = 24V DC
	05 = 24V AC
	06 = 110V AC
	07 = 230 V AC
	08 = 24V DC 1W
	09 = 24V DC downward
	11 = 12V DC downward
	12 = 24V DC downward
15 = 24V AC downward	
16 = 110V AC downward	
17 = 230 V AC downward	
18 = 24V DC 1W downward	
19 = 24V DC Earth faston downward	

Weight 305 g
 Minimum piloting pressure 1,5 bar

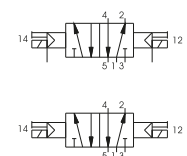

Pneumatic - Pneumatic 5 ways 3 connections

Coding: 264 **C**.53.**F**.18

Operational characteristics	
Fluid	Filtered air. No lubrication needed, if applied it shall be continuous
Max working pressure (bar)	10
Temperature °C	-5 ÷ +50
Flow rate at 6 bar with Δp=1 (NI/min)	1000
Orifice size (mm)	7.5

C	TYPE ELECTROPILOT EXHAUST 1 = on base (only for self feeding valves) 5 = on pilot (for all version)
F	FUNCTION 31 = Closed centres 32 = Open centres 33 = Pressured centres

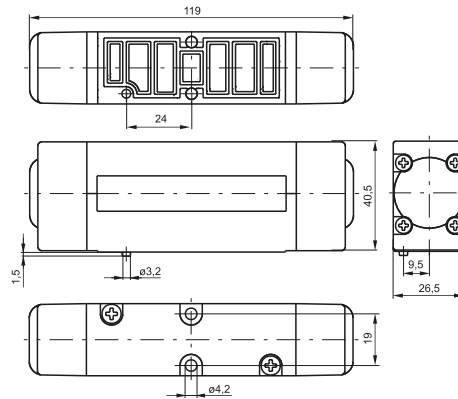

Weight 245 g
Minimum piloting pressure 3 bar

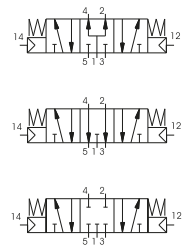

Solenoid - Solenoid 5 ways 3 connections

Coding: 264 **C**.53.**F**.**V**.**T**

Operational characteristics	
Fluid	Filtered air. No lubrication needed, if applied it shall be continuous
Max working pressure (bar)	10
Temperature °C	-5 ÷ +50
Flow rate at 6 bar with Δp=1 (NI/min)	1000
Orifice size (mm)	5

C	TYPE ELECTROPILOT EXHAUST 1 = on base (only for self feeding valves) 5 = on pilot (for all version)
F	FUNCTION 31 = Closed centres 32 = Open centres 33 = Pressured centres
V	VERSION 24 = Solenoid external-Solenoid external 35 = Solenoid-Solenoid
T	VOLTAGE 01 = 12V DC 02 = 24V DC 05 = 24V AC 06 = 110V AC 07 = 230 V AC 08 = 24V DC 1W 09 = 24V DC downward 11 = 12V DC downward 12 = 24V DC downward 15 = 24V AC downward 16 = 110V AC downward 17 = 230 V AC downward 18 = 24V DC 1W downward 19 = 24V DC Earth faston downward

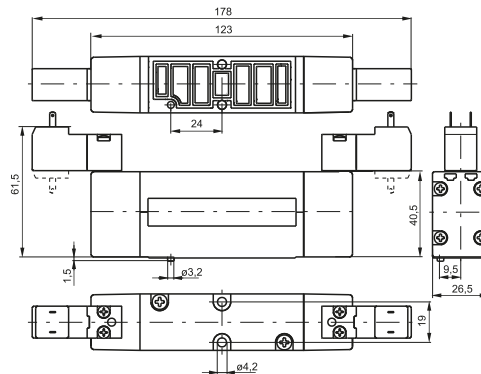

Weight 315 g
Minimum piloting pressure 3 bar

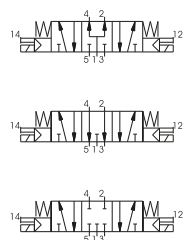

1
AIR DISTRIBUTION

Modular base

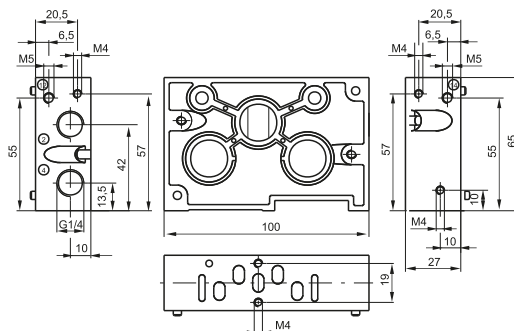

Coding: 2640.▼

VERSION
▼ 01 = Standard base
11 = Base for single separate inlet

Weight 220 g

Inlet base

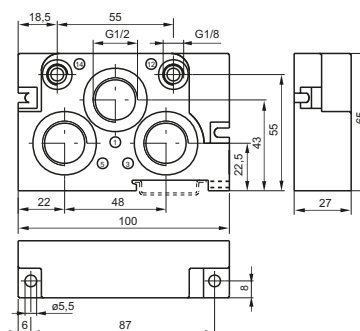

Coding: 2640.▼

VERSION
▼ 02 = Right
03 = Left

Weight 200 g

2640.02

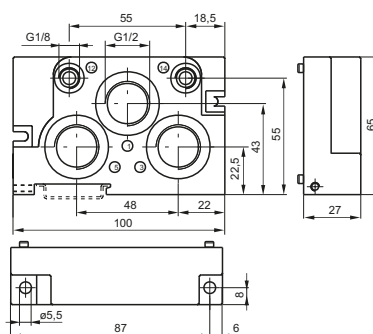

Weight 200 g

2640.03

Intermediate air intake

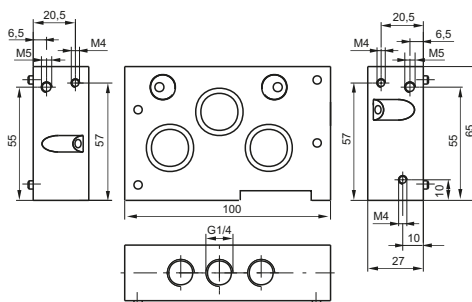

Coding: 2640.10

Closing plate

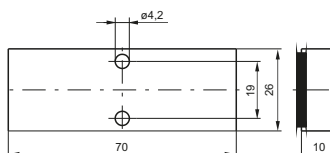

Coding: 2640.00

Weight 50 g



▶ Diaphragm plug

Coding: 2640.17



Weight 10 g