

Series P+

Basic Information

In some cases the force generated by a pneumatic actuator is not sufficient to carry out its required function. To overcome this problem it is then necessary, where possible, to either increase the working pressure or use a larger bore actuator providing it will fit within the structure of the machine.

If you cannot fit a larger actuator, the solution is to use a pressure booster to increase the air pressure to that portion of the pneumatic circuit. The booster operates using the same compressed air used by the pneumatic system and does not require an external power supply. It is easy to install and can increase the working pressure in any part of the system where ever its needed, maintaining the normal working pressure in the rest of the system.

The new pressure booster **P+** is lightweight with a new compact and linear design, **P+** has an integrated pressure regulator that adjusts the setting of the output pressure P2 which is also fitted with a pressure relief valve. The design of the internal circuit provides high flow rates and fast filling times whilst the two G1/8" manometer connections built into the body of the booster allow monitoring of the input and output pressures.

Operation

The operating principle of the device is based on a four chamber pump in which with a reciprocating movement, two chambers compress the air in the compression chamber whilst the fourth chamber is in the discharge phase. The incoming air passes through the non-return valves and supplies the compression chambers "A" and "B" at the same time.

Meanwhile, the integrated pressure regulator feeds the thrust chamber "C" via the oscillating valve which in turn compresses the air in compression chamber "B", the air is then pushed through the non-return valve and exits through the outlet connection.

When the piston reaches the end of stroke the oscillating valve changes over and feeds chamber "D" putting chamber "C" into the discharge position, thus reversing the piston and compressing the air in compression chamber "A", pushing it through the non-return valve and out through the outlet connection.

The oscillating motion of the piston allows the pressure booster to pump intensified air into the downstream circuit until the chambers reach a state of equilibrium; this in turn stops the booster.

When the downstream pressure decays the booster restarts oscillating until the state of equilibrium is re-established.

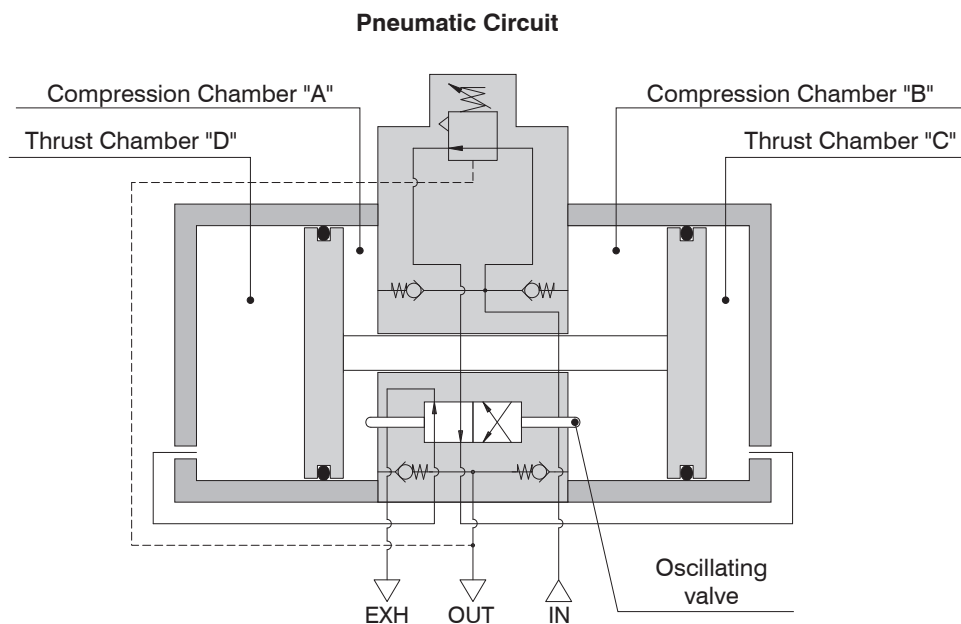

The **P+** pressure booster, is certified by ATEX:

CE II 3GD c T6 T85°C X 5°C ≤ Ta ≤ 50°C.



General Warning

It is recommended you follow the instructions below in order to prevent personal injury or damage to the booster.

- The pressure booster is supplied as standard with the regulating spring completely unwound. in this condition it is possible to detect a leak of air from below the regulating knob or through the exhaust port. this conditions is standard for the unit. When the spring is completely unwound the downstream pressure and the inlet pressure are the same. in order to increase the downstream pressure it is necessary to operate th regulation knob increasing the sping compression.
- Please apply the necessary safety measures to ensure that the booster only operates within the specified pressure range. Exceeding the maximum output pressure is dangerous.
- The Booster is fitted with a non-return valve on the output which prevents discharge of the downstream pressure, It is recommended that a 3/2 valve be installed in the OUT connection if it is necessary to rapidly discharge the downstream pressure.
- When the booster is not in use it is recommended that the inlet pressure is removed to let the booster stop, thus avoiding unexpected operation or malfunction.
- If there is not downstream air consumption it is possible to register a leak through the exhaust port of the unit. this condition is normal and is the consequence of the internal designed aimed at discharging any pressure building up in the unit in the rest condition.



Use and maintenance

The pressure booster must always be used in accordance with the operating parameters and instruction; any improper use may cause injury or malfunction. The pressure booster is not an alternative to a compressor because continuous uninterrupted operation will greatly reduce the life of the unit.

- The operating life of the device depends mainly on the operational duty cycle. Prolonged uninterrupted use without pause may reduce the operating life of the booster.
- Ensure the unit is supplied with a suitable compressed air supply, please note: appropriate filtration and lubrication may help to increase the durability of the product.
- **The input flow value must be equal or greater than double the output flow value ($Q1/Q2 > 2$).**
- **Ensure that the value of the output pressure is at least 1bar higher than the input pressure ($P2 > P1 + 1$).**
- To avoid pulsation of the output pressure during operation, it is recommended that an accumulation tank (reservoir) is installed in the downstream circuit.
- Protect the booster exhaust ports from the ingress of dust or debris.
- To reduce the noise generated by the unit, install silencers into the exhaust ports.
- Pressure booster has an average life of about 20 millions of valve cycles, depending on working conditions (every back stroke corresponds to one valve cycles).

Regolazione della pressione

The booster is fitted with an internal pressure regulator which allows regulation of the output pressure P2 and is also fitted with pressure relief valve. For correct operation of the booster, please consider the following instructions:

- Air leaking from under the adjusting knob when the spring is decompressed is not a defect but a sign that the device is working correctly.
- In order to increase the regulated pressure, pull the knob upwards to unlock, then rotate the knob in the direction indicated by the arrow (+).
- To lock the knob after the adjustment has been made, push the knob downwards until it detents in the locked position.
- To reduce the output pressure, pull the knob upwards, rotate the knob indicated by the arrow (-), the built in pressure relief valve will discharge the excess pressure from under the adjusting knob.
- Always regulate the rising pressure.



Method of calculation of the time necessary to increase the pressure in a tank of a given volume using a pressure booster.

DATA:

P1 = Inlet pressure
P2' = Initial tank pressure
P2'' = Final tank pressure
V = Tank volume

PROCEDURE:

- 1) Calculate the K' ratio between the initial tank pressure and the inlet booster pressure (P2'/P1).
- 2) Calculate the K'' ratio between the final tank pressure and the inlet booster pressure (P2''/P1).
- 3) Locate, on the chart illustrating, the booster filling time, the intersection point between the K' ratio and the curve, then trace a vertical line from the intersection point to the vertical axis and read the correspondent value T' (in the example chart, to a ratio of 0.8 corresponds a time value of about 3.6 seconds).
- 4) Repeat the operation for the K'' ratio, obtaining the T'' time.

$$5) \text{ Apply the formula } T = \frac{V}{5} \cdot (T'' - T')$$

to obtain the total time needed to take the tank of volume V from the pressure value P2' to the pressure value P2''.

Example of calculation of the necessary time to take a 10L tank from the pressure value P2' to the value P2''

K' = 0,8 T' = 3,6 sec. V = 5L.
K'' = 1,5 T'' = 12 sec.

$$T = \frac{5}{5} \cdot (12 - 3,6) = 8,4 \text{ sec.}$$

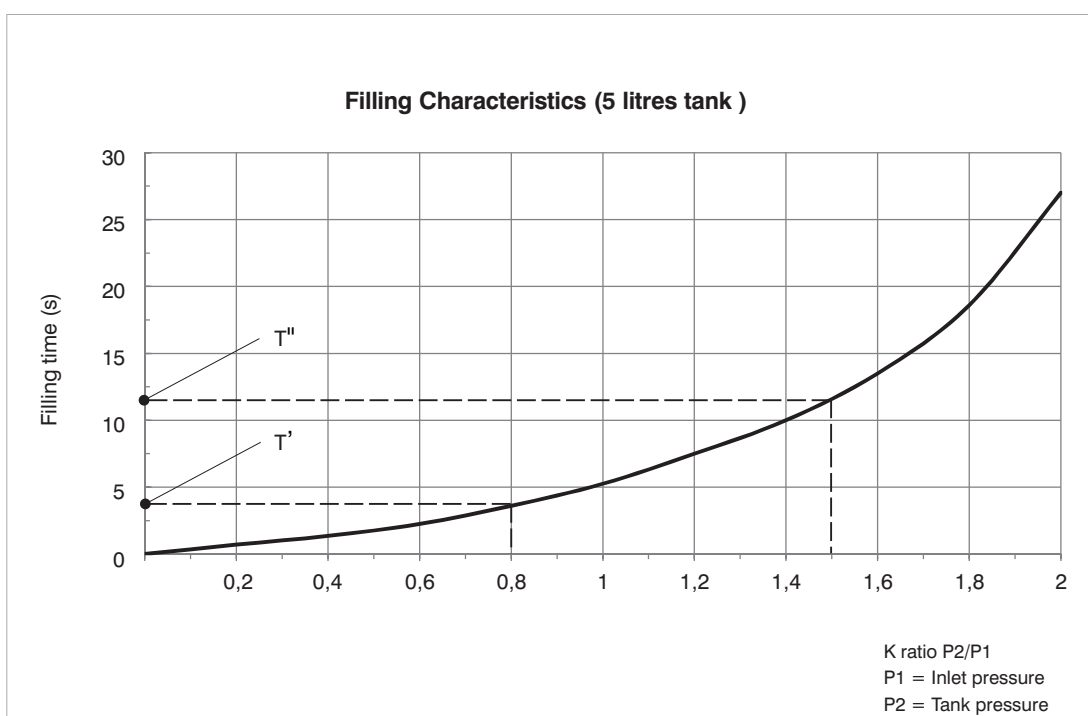

Pressure booster in Technopolymer Ø40

ATEX CE II 3GD

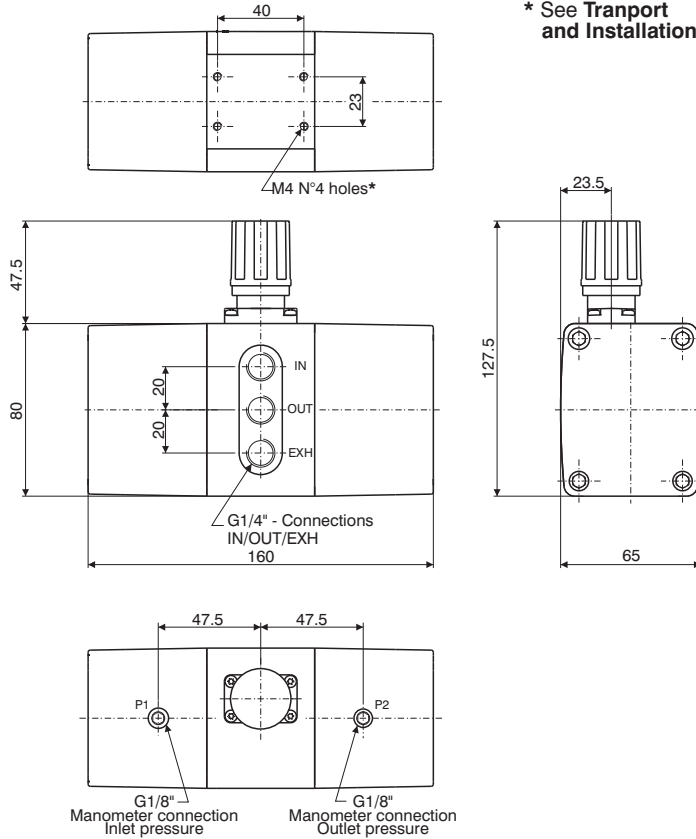
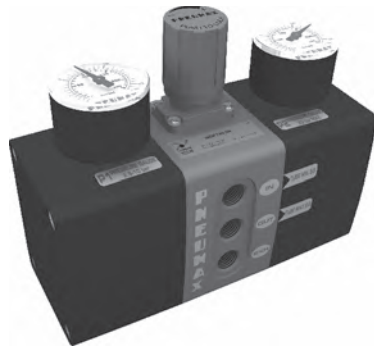

* See Transport and Installation

Ordering code	MDPT40.2R.⊙
MANOMETER OPTIONS	Without options = Standard without manometer
⊙	A = Manometer P1 0-12 bar Manometer P2 0-20 bar
	B = Manometer P1 0-12 bar Manometer P2 0-16 bar
	C = Manometer P1 0-12 bar Manometer P2 0-12 bar

2
AIR SERVICE UNITS

Operational characteristics

- Pressure Booster with max. 2:1 Compression ratio
- Automatic operation for use with compressed air only
- Maintains downstream air when the supply pressure fails (Providing the circuit has no leakage)
- Integrated regulator for output pressure control, with overpressure relief valve
- IN,OUT and EXH connections – G1/4" on the same side
- Manometer connections G1/8" to monitor and control the input and output pressures
- Body and cover in technopolymer
- Connections in technopolymer

Technical characteristics

Connections (IN / OUT / EXT)	G1/4"
Manometer connections P1/P2	G1/8"
Working pressure (bar) [Min. - Max.]	2,5 ÷ 10
Working temperature (°C) [Min. - Max.]	-5 ÷ + 50
Multiplication ratio max.	2 : 1
Assembly position	Any
Pressure regulation	Manual with relieving
Weight	905 gr.
Max. fittings torque	G1/8 = 4 N/m G1/4 = 9 N/m

Characteristics curves

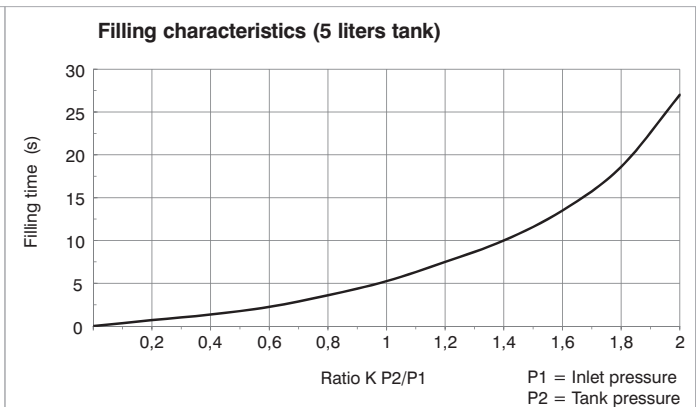
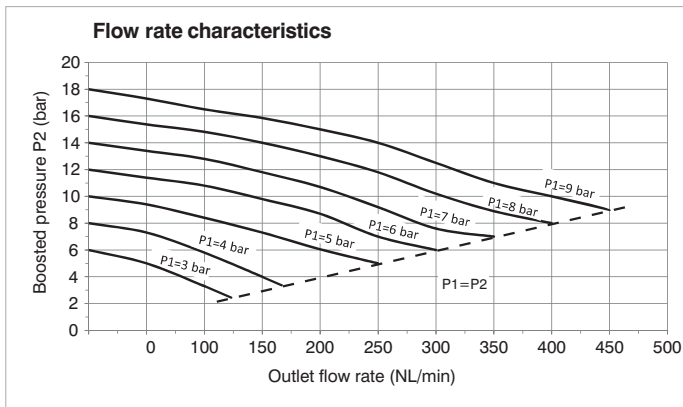

Transport and Installation:

The installation and implementation of the device must be done by skilled personnel. Respecting the safety requirements specified in the UNI norm **UNI EN 983-97 Machinery Safety – Safety Requirements concerning oleo-hydraulic and pneumatic systems** and their components.

The following instructions are essential for a correct installation:

- Do not use the green knob to lift and transport the device, because it could rip off causing injuries or damaging objects..
- Install the booster by fixing it through the threaded M4 holes on the body of the machine or using the special accessories (see the "Accessories" chapter).

Direct Wall Fixing

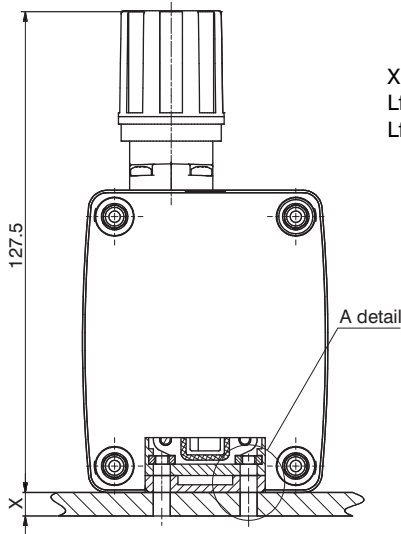

X = Thickness of the support surface
Lf = Fixing screw thread length
Lf = X + 10

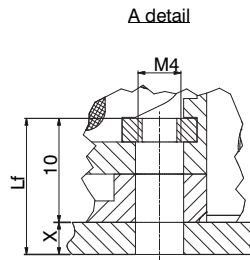

Fixing with a steel plate fixing clamp.

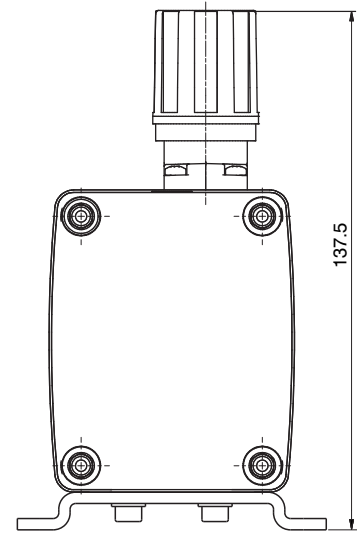

Bracket



Weight gr. 94,5
Complete with booster fixing screws

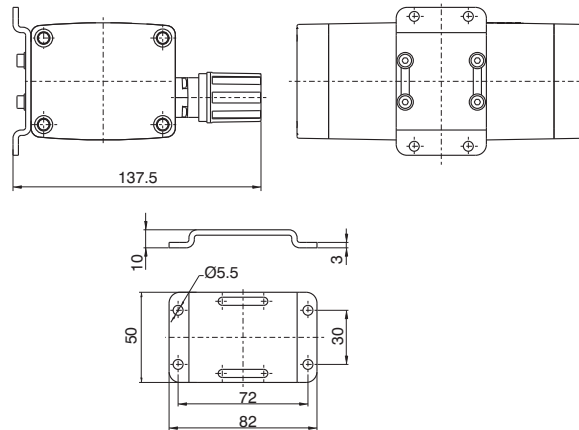

Ordering code

T1740.01

Manometer D.40

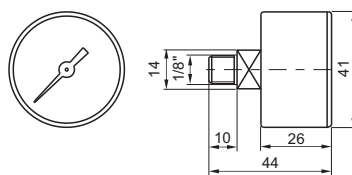

Weight gr. 85

Ordering code

17070A.S

SCALE

A = 0-4 bar

B = 0-6 bar

C = 0-12 bar

D = 0-16 bar

E = 0-20 bar