

Oil removal filters (DBV - DCV - DAV)

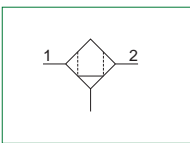

- ▶ Oil removal filter with coalescing filter element
- ▶ Available in 2 sizes with connections from 3/8" to 1"
- ▶ Particle removal up to 0,01 μm
- ▶ Oil residual 0,01 ppm
- ▶ Cartridge clogging level display:
 - green color - ok
 - red color - warning ($\Delta p > 0,5$ bar)
- ▶ Bowl assembly via bayonet type quick coupling mechanism with safety button
- ▶ Automatic drain mounted as standard
- ▶ Atex certification (II 2GD or II 3GD)



Note

In order to ensure the high level of filtration, it is recommended that a 5μ filter is installed before the coalescing filter. In order to ensure that any fluid discharged by the auto drain assembly is adequately drained away, it is recommended you use a 6mm fitting and tube.

Technical characteristics			
Size		Size 3	Size 4
Body and connections type		Technopolymer body, integrated technopolymer connections (T version) Technopolymer body, metal connections (N version)	Aluminium body, integrated aluminium connections (P version)
Protection and bowl type		Technopolymer protection - PC bowl Technopolymer protection - PA bowl Metal protection - PC bowl Metal protection - PA bowl Metal bowl (blind metal bowl)	
IN / OUT connections	T version	G1/2"	not available
	N version	G3/8" - G1/2" - 1/2" NPT	
	P version	G1/2"	G1"
Assembly configuration		Stand alone	Panel mounted
Assembly positions		Vertical ±5°	
Filter pore size		Particle removal up to 0,01 μm Oil residual 0,01 ppm	
Bowl capacity		30 cm ³	90 cm ³
Condensation drain		Automatic	
Max. fittings torque IN / OUT connections		G3/8" metal: 25Nm G1/2" metal: 30Nm G1/2" technopolymer: 22Nm	G1" metal: 35Nm

Operational characteristics		
Size	Size 3	Size 4
Condensation drain	Automatic	
Maximum working pressure	10 bar	
Minimum working pressure	0,5 bar	
Working temperature	-5°C +50°C	

2
AIR TREATMENT



Weights				
	Size	Size 3 Standard cartridge	Size 3 Oversize cartridge	Size 4
Fully technopolymer version		416 g	634 g	/
Technopolymer body version, aluminium bowl protection and technopolymer bowl		453 g	671 g	/
Technopolymer body version, aluminium bowl		526 g	742 g	/
Aluminium body version, technopolymer protection and bowl		538 g	661 g	1230 g
Aluminium body version, aluminium bowl protection and technopolymer bowl		575 g	698 g	1374 g
Aluminium body version and aluminium bowl		647 g	769 g	1398 g

Materials

Exploded sectioned

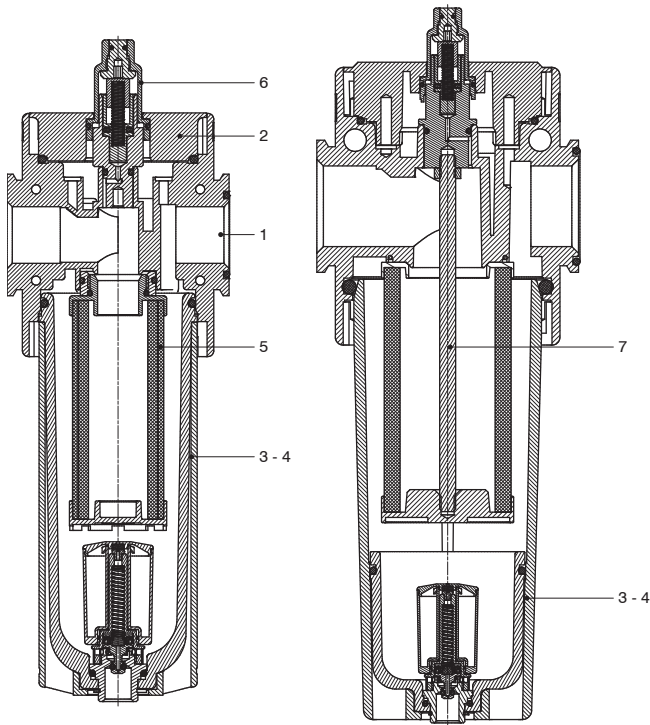

Oil removal filter		
1	Body	Polyamide Die-cast aluminium
2	Upper plug	Polyamide
3	Technopolymer bowl	Polycarbonate Polyamide
4	Metal bowl Bowl protection	Die-cast aluminium Polyamide - Die-cast aluminium
5	Filtering element	/
6	Visual indicator	Polycarbonate
7	Tie rod	Steel (only for size 4)
8	Automatic drain	/

2
AIR TREATMENT

Design

Size 3
Technopolymer protection

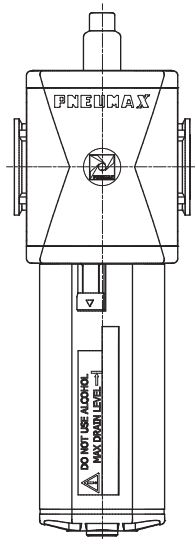

Size 3
Protection / Metal bowl

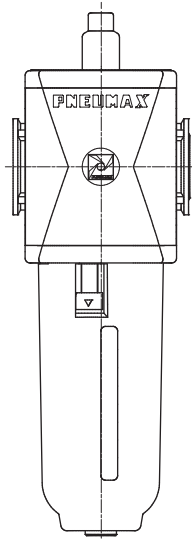

Size 3 - Oversize cartridge
Technopolymer protection

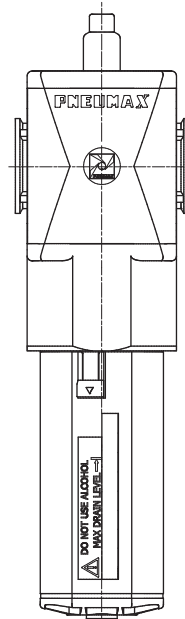

Size 4
All versions

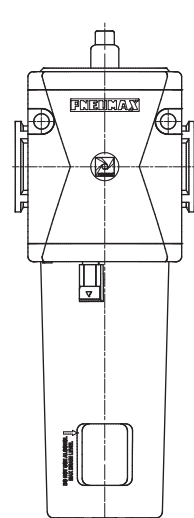

Order codes

T 17 3BDBV T

Version
N : Technopolymer body and metal inserts (not available for size 4)
T : Technopolymer body and thread (not available for size 4)
P : Aluminium body

Size and connections
3ADBV : Size 3 - G3/8" standard cartridge only for N version
3BDBV : Size 3 - G1/2" standard cartridge for all versions
3CDBV : Size 3 - 1/2" NPT standard cartridge only for N version
3BDCV : Size 3 - G1/2" oversize cartridge only for P version
4BDAV : Size 4 - G1" standard cartridge only for P version

Bowl options
: Technopolymer protection - PC bowl
N : Technopolymer protection - PA bowl
P : Metal protection - PC bowl
R : Metal protection - PA bowl
T : Metal bowl

Example : T173BDBVT : Size 3 oil removal filter G1/2", standard cartridge, metal bowl

Characteristic curves

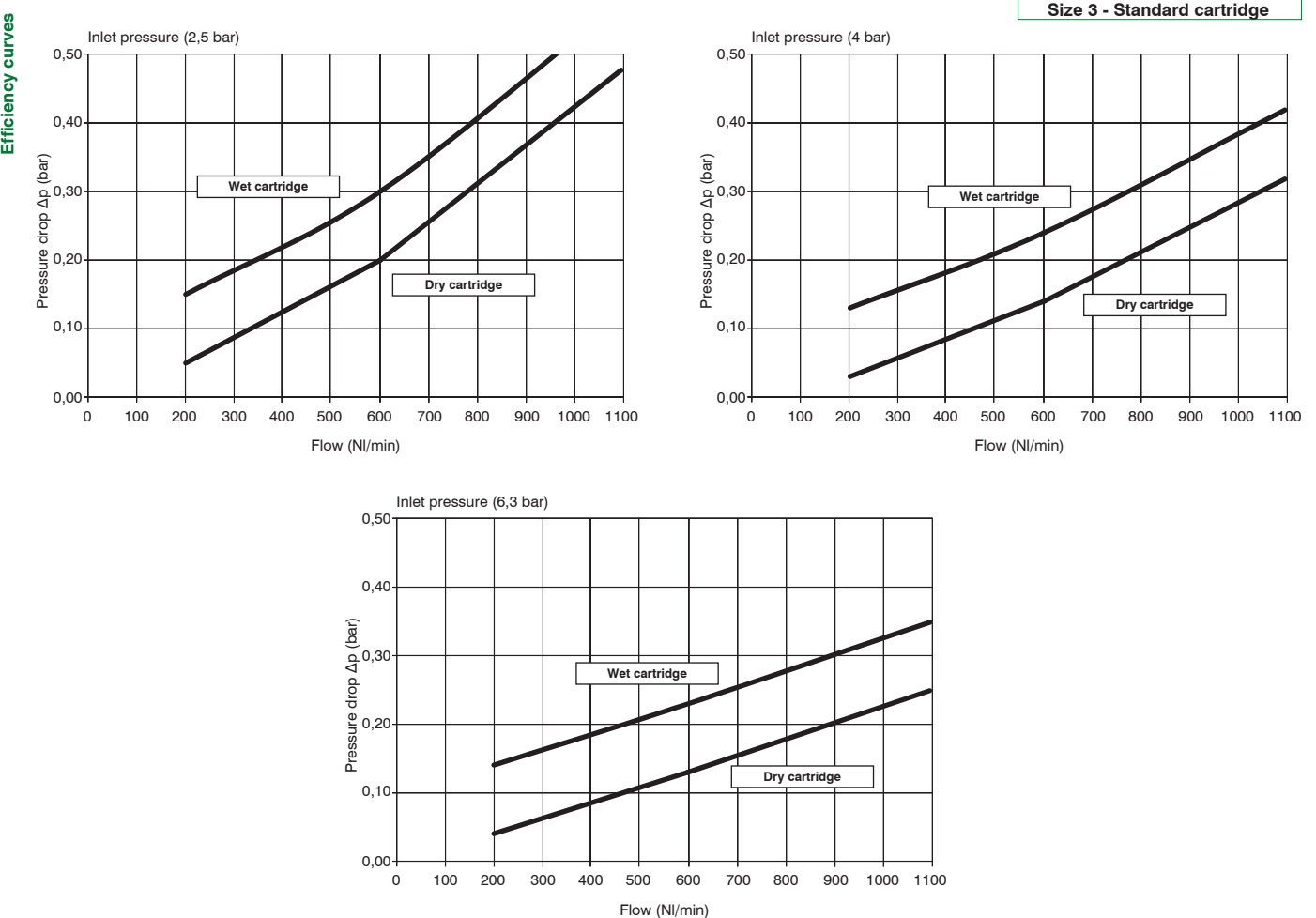



Size 3 - Oversize cartridge

Efficiency curves

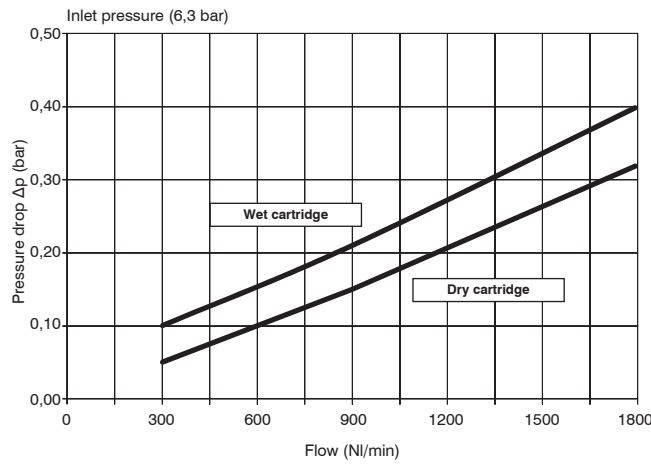
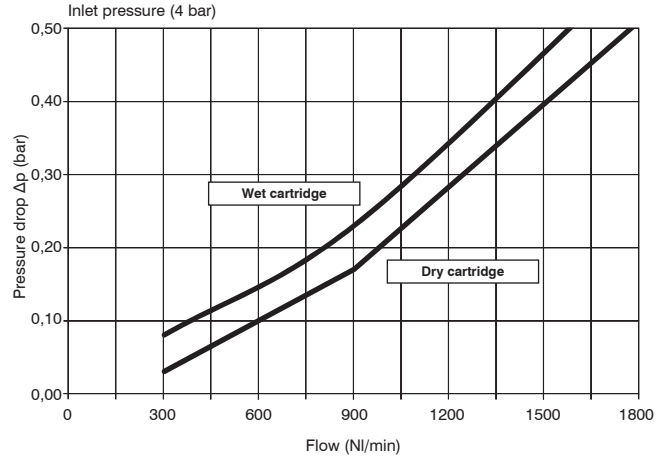
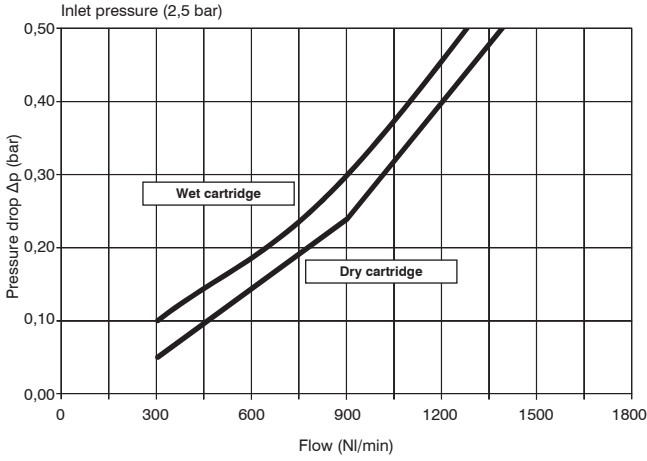

Size 4 - Standard cartridge

Efficiency curves

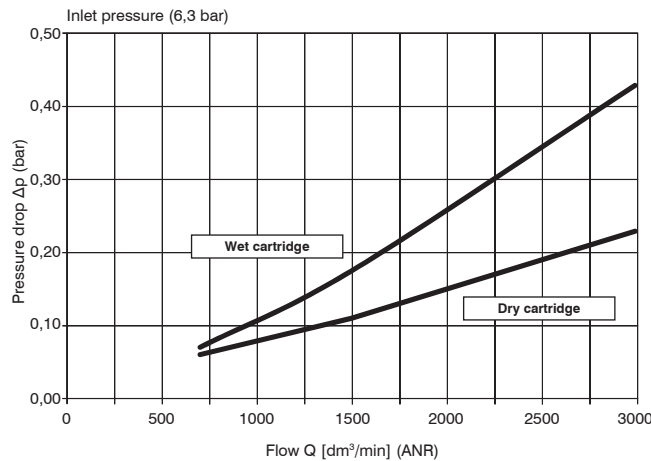
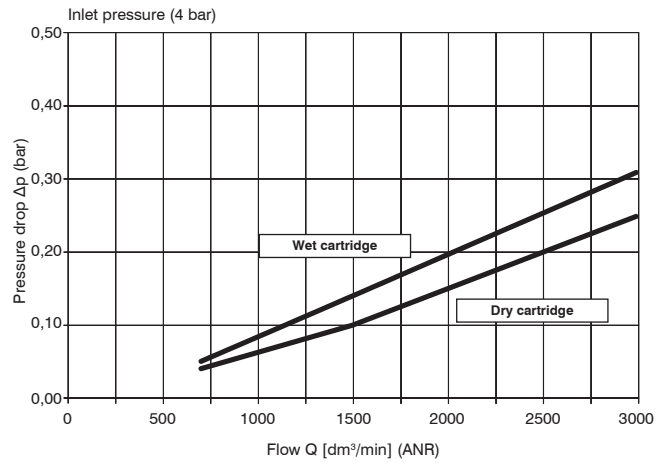
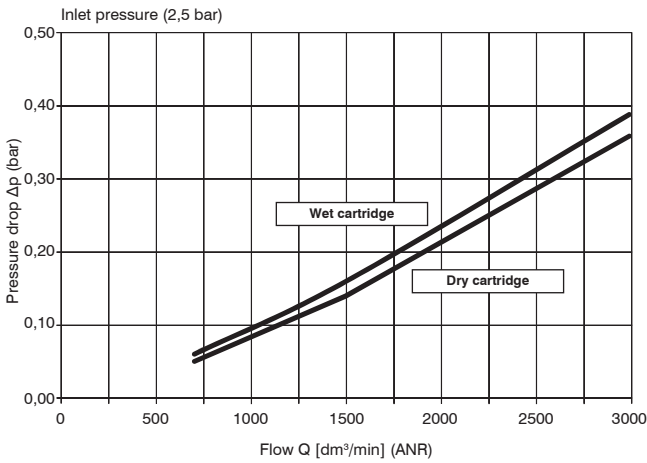

Dimensions

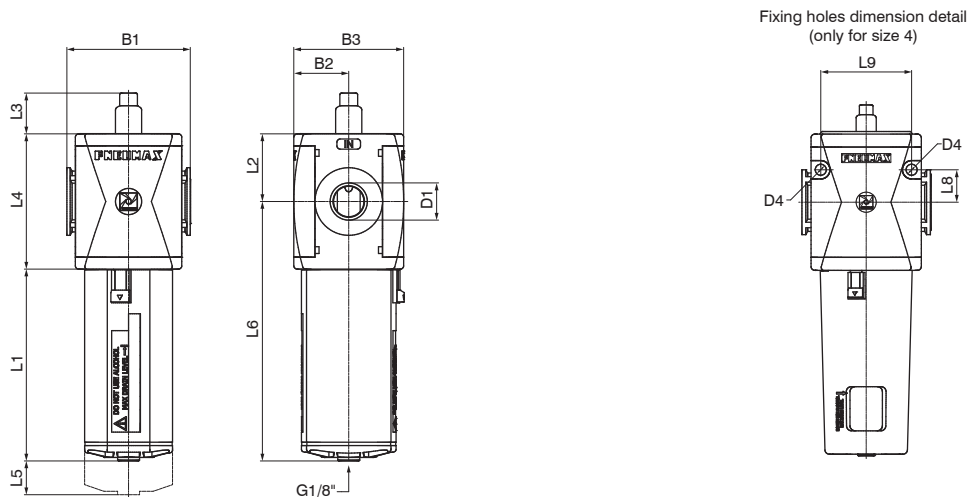

Model	B1	B2	B3	D1		L1 - Bowl material		L3	L4		L5	L8	L9
				Standard cartridge	Oversize cartridge	Technopolymer	Metal		Standard cartridge	Oversize cartridge			
#173..	73	32,5	65	G3/8" G1/2" 1/2" NPT	G1/2"	113,5	116	24,1	80	118	65	/	/
#174..	99	44	88	G1"	/	143	145,5	22,5	105	/	103	25	70