

► Carbon filters (DD)

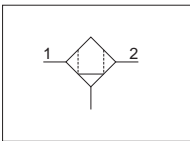

- Carbon filter
- Available in 2 sizes with connections from 3/8" to 1"
- Active carbon cartridge with built in particulate filter
- Used to remove oil vapours, hydrocarbons, odours and particles
- Oil residue up to <0,003 ppm (max input aerosol 0.01 ppm)
- High absorption capacity, with low differential pressure
- Filtering performances 99.97% (particles up to 0.01 μm)
- Bowl assembly via bayonet type quick coupling mechanism with safety button
- Semi-automatic drain
- Atex certification (II 2GD or II 3GD)
- Inlet pressures up to 20 bar

2  
AIR TREATMENT



**Note**

A 5μ filter, coalescing filter and oil removing filter must be installed prior to the carbon filter, this is to ensure that the carbon filter operates correctly and safe guard the life of the active carbon element. It may also be necessary to replace the carbon element at fixed intervals.

Technical characteristics			
	Size	Size 3	Size 4
<b>Body and connections type</b>		Technopolymer body, integrated technopolymer connections (T version) Technopolymer body, metal connections (N version)	/ / Aluminium body, integrated aluminium connections (P - L versions)
<b>Protection and bowl type</b>		Technopolymer protection - PC bowl Technopolymer protection - PA bowl Metal protection - PC bowl Metal protection - PA bowl Metal bowl (blind metal bowl)	
<b>IN / OUT connections</b>	T version	G1/2"	not available
	N version	G3/8" - G1/2" - 1/2" NPT	
	P and L version	G1/2"	G1"
<b>Assembly configuration</b>		Stand alone	Panel mounted
<b>Assembly positions</b>		Vertical ±5°	
<b>Oil residue</b>		< 0,003 ppm (max input aerosol 0.01 ppm)	
<b>Bowl capacity</b>		68 cm <sup>3</sup>	90 cm <sup>3</sup>
<b>Condensation drain</b>		Semi-automatic	
<b>Max. fittings torque IN / OUT connections</b>		G3/8" metal: 25Nm G1/2" metal: 30Nm G1/2" technopolymer: 22Nm	G1"metal: 35Nm

Operational characteristics			
	Size	Size 3	Size 4
<b>Condensation drain</b>		Semi-automatic	
<b>Maximum working pressure</b>		13 bar 20 bar (only with body and metal bowl)	
<b>Minimum working pressure</b>		0,5 bar	
<b>Working temperature</b>		-5°C +50°C -30°C +80°C (only for P version and metal bowl) -40°C +80°C (only for L version and metal bowl)	
<b>Cartridge life</b>		2000 hours	

Weights			
	Size	Size 3	Size 4
Fully technopolymer version		395 g	/
Technopolymer body version, aluminium bowl protection and technopolymer bowl		432 g	/
Technopolymer body version, aluminium bowl		505 g	/
Aluminium body version, technopolymer protection and bowl		518 g	1201 g
Aluminium body version, aluminium bowl protection and technopolymer bowl		554 g	1344 g
Aluminium body version and aluminium bowl		628 g	1368 g

**Materials**

Exploded sectioned

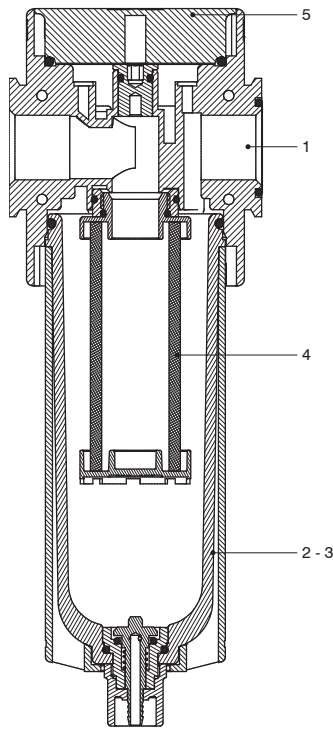

Carbon filter		
1	Body	Polyamide Die-cast aluminium
2	Technopolymer bowl	Polycarbonate Polyamide
3	Metal bowl Bowl protection	Die-cast aluminium Polyamide - Die-cast aluminium
4	Filtering element	Activated carbon
5	Plug	Polyamide Die-cast aluminium

2

AIR TREATMENT

**Design**

**Size 3**  
Technopolymer protection

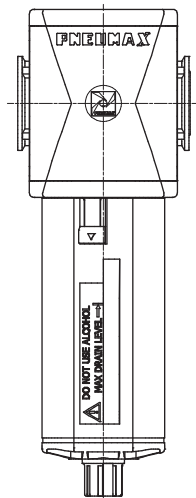

**Size 3**  
Protection / Metal bowl

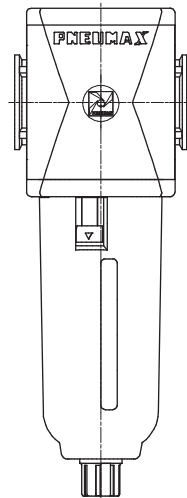

**Size 4**  
All versions

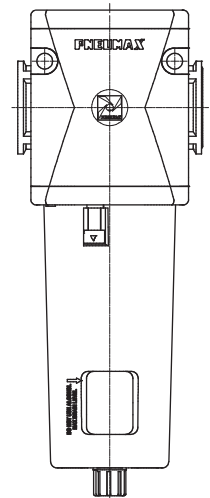



**Order codes**

T 17 3B DD T

Version
N : Technopolymer body and metal inserts (not available for size 4)
T : Technopolymer body and thread (not available for size 4)
P : Aluminium body
L : Aluminium body, low temperature

Size and connections
3A : Size 3 - G3/8" only for N version
3B : Size 3 - G1/2" for all versions
3C : Size 3 - 1/2" NPT only for N version
4B : Size 4 - G1" only for P - L versions

Bowl options
: Technopolymer protection - PC bowl
N : Technopolymer protection - PA bowl
P : Metal protection - PC bowl
R : Metal protection - PA bowl
T : Metal bowl

**Example : T173BDDT** : Size 3 carbon filter G1/2" metal bowl

2  
AIR TREATMENT

Characteristic curves

Size 3

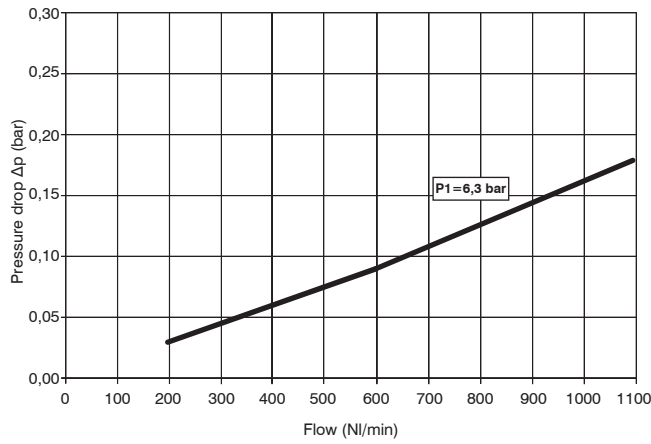
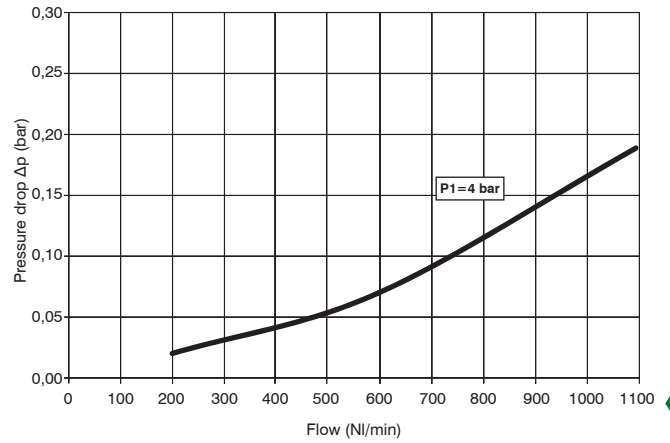
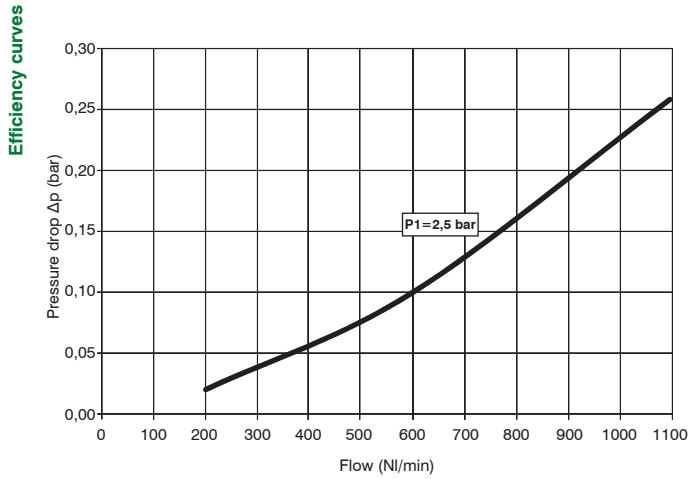

Size 4

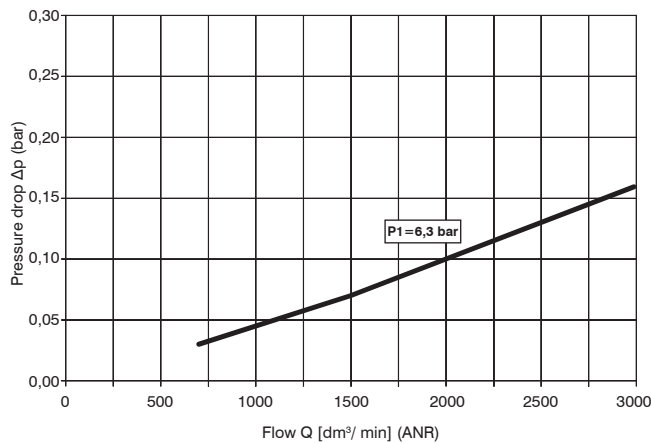
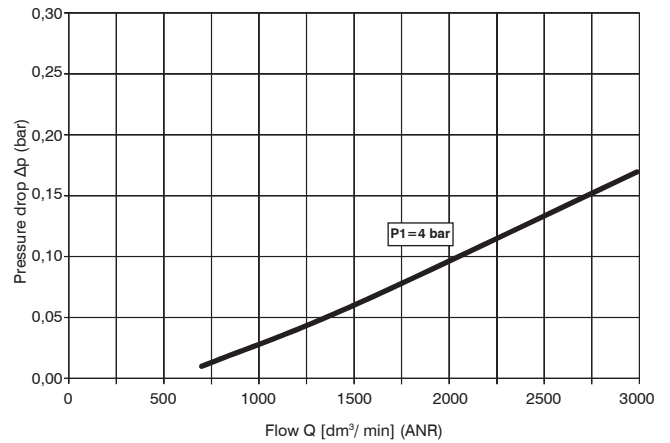
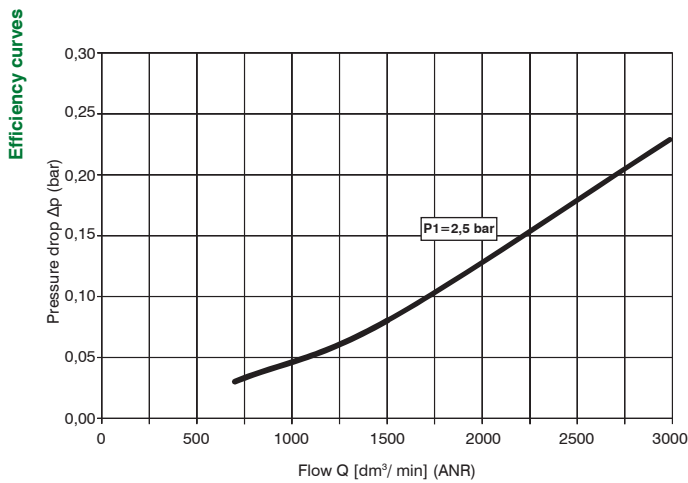

2

AIR TREATMENT

**Dimensions**

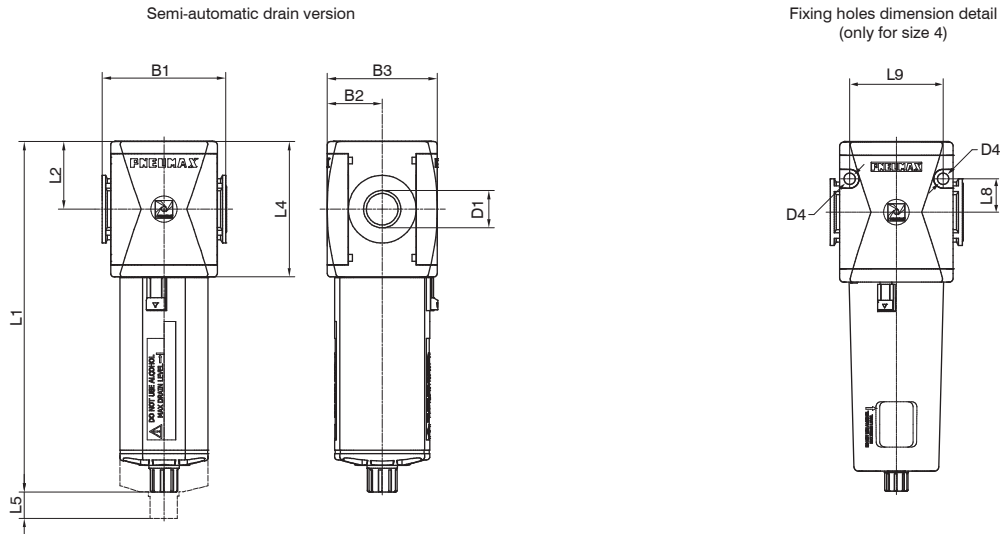

2 AIR TREATMENT

Model	B1	B2	B3	D1	D4	L1 - Bowl material		L2	L4	L5	L8	L9
						Technopolymer	Metal					
#173..	73	32,5	65	G3/8" G1/2" 1/2" NPT	/	207,2	209,5	40	80	65	/	/
#174..	99	44	88	G1" 1" NPT	8,5	262	264,5	52,5	105	103	25	70

**Variable dimensions**

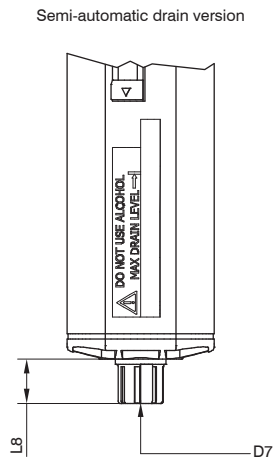

Model	L8 - Bowl material		D7
	Technopolymer	Metal	
Semi-automatic drain	15,7	18	Plastic hose connector