

VGS™3040 WITH PROFILE MOUNT



- ▶ COAX® cartridge integrated.
- ▶ Easy attachment to standard extrusion and profile systems.
- ▶ Adjustable position.
- ▶ Quick setup and change-over.

TECHNICAL DATA

Description	Unit	Value
Feed pressure, max.	MPa	0.7
Noise level, range	dBA	65-74
Material		Al, NBR, PA
Temperature range	°C	-10-80
Weight, range	g	225-775

PERFORMANCE TABLES

Depending upon choice of COAX® Cartridge, performance data of the VGS™3040 can be found in the tables for vacuum flow and evacuation time on the VGS™3040 or COAX® Cartridge datasheets.

ORDERING INFORMATION

1. Housing		VGS Code
Housing Left hand		00
Housing Right hand		01
2. COAX® cartridge		VGS Code
COAX® cartridge MINI Pi12-2		AB
COAX® cartridge MINI Pi12-3		AC
COAX® cartridge MINI Pi12-2, non-return valve		AD
COAX® cartridge MINI Pi12-3, non-return valve		AE
COAX® cartridge MINI Si08-2		AF
COAX® cartridge MINI Si08-3		AG
COAX® cartridge MINI Si08-3, non-return valve		AI
COAX® cartridge MINI Si08-2, non-return valve		AH
COAX® cartridge MINI Xi10-2		AJ
COAX® cartridge MINI Xi10-3		AK
COAX® cartridge MINI Xi10-2, non-return valve		AL
COAX® cartridge MINI Xi10-3, non-return valve		AM
3. Mounting style		VGS Code
Mounting Profile mount		08
4. Energy saving		VGS Code
No energy saving		AA
Energy saving Vacustat 65 -kPa		AB
Energy saving Vacustat, Adjustable (factory set at 45 -kPa)		AC
<i>For detailed information on Vacustat, see separate datasheet.</i>		
5. Release function		VGS Code
Release Blow-off		01
Release AQR 02 internal		02
Release AQR 02 external		03
<i>For detailed information on Blow-off and AQR 02, see separate datasheets.</i>		
6. Vacuum connection		VGS Code
G3/8" female		AA
G3/8" male - 3/8" NPT male adapter		AB

Example	Ordering number
VGS™3040 with left hand housing, COAX® cartridge MINI Pi 12-2, mounting Profile mount, no energy saving, release blow-off, G3/8" female vacuum connection	VGS3040 00 AB 08 AA 01 AA

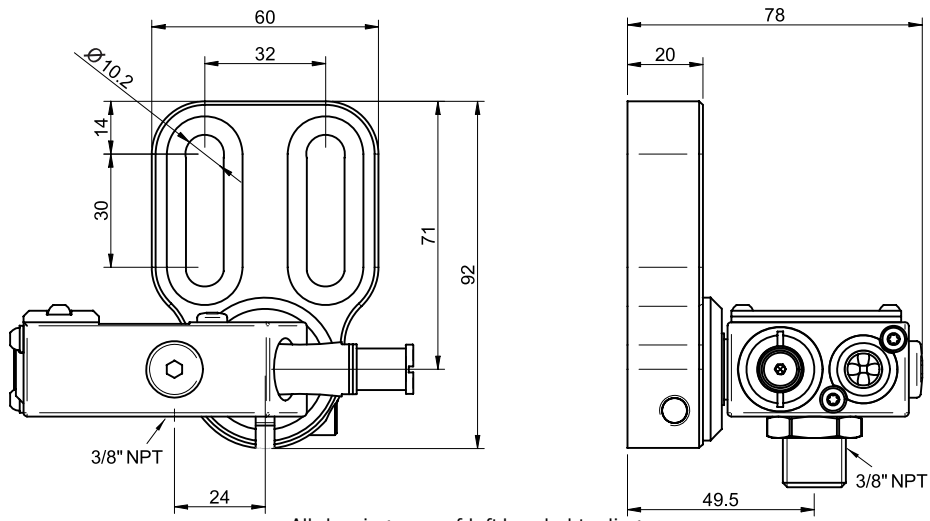

Vacuum grippers
VGS™3040